optiplus

 **B&S**
QUALITY MADE

**ALLES
VOOR DE
WERKPLAATS
2020 | 21**





Beste Opticien,

Alsjeblieft: de nieuwe B&S Werkplaatscatalogus! In deze nieuwste twee jaarlijkse catalogus vind je alles wat je nodig hebt voor in je werkplaats, van pads en schroeven tot tangen en föhns. Met onze catalogus geven we je een handig overzicht op papier van onze werkplaatsproducten, aangevuld met Tips & Tricks en informatie over onze producten. Natuurlijk kun je al onze producten snel en gemakkelijk online bestellen op onze webshop www.optiplus.nl / www.optiplusbelgium.be!

Deze keer staat de catalogus in het teken van het thema „**Brillengezondheid**”. Een woord dat je niet terugvindt in het woordenboek, maar waar we wèl veel belang aan hechten. Want goed en ontspannen zicht begint met een comfortabele, functionele, goed afgepaste bril, oftewel een gezonde bril! Een gezonde bril blijft gezond door kundig uitgevoerde reparaties. Jij zorgt daarbij voor de professionele technische expertise, wij zorgen voor de hoogwaardige onderdelen, de met zorg ontwikkelde apparaten en de hoge kwaliteit precisiegereedschappen.

Deze catalogus bestaat uit zeven hoofdstukken die oplossingen laten zien voor verschillende vraagstukken. Wil je bijvoorbeeld boorgaten vullen? Dan vind je de UV gel die je nodig hebt, in hoofdstuk E – Eerste hulp maatregelen. Wil je solderingen na bewerken? Dan is het gereedschap dat je zoekt te vinden in hoofdstuk C – precisiegereedschappen voor gecompliceerde opdrachten. Zo kun je gemakkelijk vinden wat je zoekt en je klant snel verder helpen met het „**genezen**” van hun bril!

Om je verder te ondersteunen, hebben we de categorie **Tips & Tricks** uitgebreid. Hier zie je stap-voor-stap uitleg met afbeeldingen van complexe reparaties en producttoepassingen. Op onze webshop vind je korte filmpjes van deze Tips & Tricks, ook handig voor je opticiens in opleiding. Tot slot vind je verspreid over de hoofdstukken de serie „**Top Product**”. Hier ontdek je producten die je dagelijkse werk in de werkplaats nog efficiënter laten verlopen.

Aanpassingen, reiniging, reparatie of boren, frezen en solderen – we hebben de nodige tools en onderdelen voor je. Maar wij geloven dat het allerbelangrijkste product van een leverancier de service is. Ons gepassioneerde team doet daarom iedere dag zijn best om je de beste service en ondersteuning te geven. Aarzel dan ook niet om ons te bellen, e-mailen of whatsappen met je vragen of opmerkingen!

Team Optiplus,
Kees, Harke, Jack, Edechiena, Chantal, Arjan, Robin, Ivo, Paula, Jacco en Marieke

Inhoud 2020 | 21



TIPS & TRICKS

Verruim uw knowhow met gedetailleerde afbeeldingen van gecompliceerde werkfasen- en toepassingen.



TOP PRODUCT

Geselecteerde artikelen voor een efficiënte aanpak in uw werkplaats.

MACHINES EN APPARATEN

Voorkomen en behandelen



- A 2 PD meters
- A 6 Topsterktemeters
- A 8 Ultrasoons
- A 12 Föhns
- A 18 Groefmachines
- A 22 Handslijpstenen
- A 24 Polijstmotoren
- A 26 Boormachines
- A 31 Soldeerapparaten
- A 34 Kleine apparaten
- A 39 Glaskleurmachine en toebehoren
- A 40 CLAVULUS en toebehoren

TANGEN

elke greep past



- B 2 Paralleltangen
- B 4 Overzicht: eLite-, Standaard-tangen
- B 6 Inklinatie tangen
- B 8 Richt tangen
- B 10 Nylor tangen
- B 12 Tips & tricks: Curve tang
- B 16 Spits tangen
- B 19 Sluitbloktangen
- B 20 Padricht tangen
- B 22 Tips & tricks: Glasbril tangen
- B 25 Kopkniptangen
- B 30 Tips & tricks: Bionic Thumb
- B 33 Centertangen
- B 34 Glasversteltangen
- B 36 Deblocker tangen
- B 38 Stempeltang
- B 39 Zijknip- & kopkniptangen
- B 43 Tips & tricks: flexscharniertang
- B 45 Tangenstanders
- B 46 Tangengrepen

PRECISIEGEREEDSCHAPPEN

voor gecompliceerde opdrachten



- C 2 Schroevendraaiers & moersleutels
- C 14 Derde hand
- C 15 Aambeeldtoren
- C 16 Pincetten
- C 18 Knippen en snijden
- C 21 Ruimers
- C 22 Tappen
- C 24 Tips & tricks: Glasbeschermer Henry
- C 26 Tips & tricks: Nylorinlegdraad instrument
- C 27 Montagehulp voor glasbrillen
- C 28 Tips & tricks: Schroevenkorter
- C 31 Kleine gereedschappen
- C 32 Boren en frezen
- C 37 Gereedschaphouders
- C 38 Vijlen
- C 42 Bankschroeven
- C 43 Zagen

OFTALMOLOGIE

Instrumenten voor de juiste diagnose



- D 2 Pasbrillen
- D 5 Pasdozen
- D 8 Kruiscilinders en balanslinialen
- D 10 Occluder & kleurtafels
- D 11 Tips & tricks: Prismafoliën
- D 12 Foliën
- D 13 Leesdelen
- D 14 Oogdoppen
- D 15 Occlusiefoliën
- D 16 KAANS Patch
- D 17 Veiligheidsbrillen assortiment
- D 18 Contactlens accessoires
- D 22 Sferometers en diktemeters
- D 24 Schuifmaat
- D 26 Tips & tricks: The Cube
- D 28 Linialen

VERBRUIKSARTIKELEN

voor eerste hulp maatregelen



- E 2 Afnameblokken en glasplakkers
- E 8 Bescherm- en anti-torsiefolien
- E 9 Slijpwatertoevoeging en reinigingssteen
- E 10 Markeerstiften
- E 11 UV gel
- E 12 Lijmen en borgmiddelen
- E 17 Oliën en reinigers
- E 20 Kleurpoeder
- E 21 Desinfectiedoeken
- E 22 Tips & tricks: Plasti Dip
- E 24 Reparatieverven en stiften
- E 27 Tips & tricks: polijsten
- E 28 Schijven en borstels
- E 30 Glans-, polijst- en slijppasta's en was
- E 32 Slijp- en schuurmiddelen
- E 34 Soldeer en vloeimiddelen

BRILONDERDELEN

in exacte dosering met doeltreffende werking



- F 2 Overzicht neuspads
- F 13 Plakpads, padplaatjes
- F 14 Tips & tricks: zelfklevende neuspadvkussen
- F 16 Tips & tricks: padsteunen
- F 17 Padsteunen
- F 20 Overzicht schroeven en moeren
- F 33 Tips & tricks: 4-in-1-schroeven
- F 50 Ringen en hulzen
- F 54 Scharnieren
- F 58 Overzicht oortips en veren
- F 66 Tips & tricks: kruloortips
- F 74 Tips & tricks: krimpkoukous
- F 76 Lange oortips
- F 77 Veren
- F 81 Onderdelen voor glasbrillen
- F 84 Inlegrand
- F 85 Nylordraad
- F 86 Oefenmateriaal

OPBERGSYSTEMEN

voor een effectief behandelplan



- G 2 Presenteerblad
- G 3 Orderhoezen
- G 5 Prijsetiketten
- G 6 Werkbakken
- G 10 Onderdelenbakken en klapboxen
- G 14 Cosmetica spiegels





MACHINES EN APPARATEN

Voorkomen en behandelen



- A 2 PD meters
- A 6 Topsterktemeters
- A 8 Ultrasoons
- A 12 Föhns
- A 18 Groefmachines
- A 22 Handslijpstenen
- A 24 Polijstmotoren
- A 26 Boormachines
- A 31 Soldeerapparaten
- A 34 Kleine apparaten
- A 39 Glaskleurmachine en toebehoren
- A 40 CLAVULUS en toebehoren



Vaak gekopieerd, maar nooit geëvenaard!

De in Japan gemaakte PD meter overtuigt door de verwerkingskwaliteit, de ergonomie en het uitstekende design. Door de duidelijke en eenvoudige bediening, de digitale aanduiding, de geïntegreerde HVA meting en de aantrekkelijke vormgeving is deze PD meter een voorbeeld van samenspel tussen vorm en functie. Met de design PD meter kunt u uw vakmanschap laten zien.

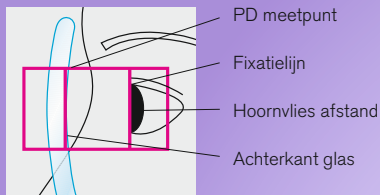

PD meter

Mooi vormgegeven PD meetapparaat van B & S.
Door het ergonomisch design ligt het perfect in de hand.

- Omschakeling van monoculaire- en binoculaire meting
- Helder fixatielicht garandeert een gemakkelijk afleesbaar hoornvliesreflex
- Groot, gemakkelijk afleesbaar display met gelijktijdige aanduiding van totale en enkele PD
- Omschakeling van PD meting naar HSA meting
- Traploze meting van de PD
- Werkt op batterijen en schakelt automatisch uit na 1 minuut
- Vergrotingsschuif

2385 00

Technische specificaties

Aanduiding:	LC Display
Fixatie:	Lichtkruis
Meetbereik:	
Binoculair:	46,0 tot 82,0 mm in 0,5 mm stappen
Monoculair:	23,0 tot 41,0 mm in 0,5 mm stappen
Meetafstand kiesbaar tussen:	30, 35, 40, 50, 65 cm; 1,0, 2,0 m; ∞
Voeding:	4 x 1,5 V Micro (type AAA)
Afmetingen (B x H x D):	155 x 52 x 220 mm
Gewicht:	655 g incl. batterijen

 36 maanden garantie!

 Onderdelen verkrijgbaar bij uw leverancier.



PD meter

PD meter met digitale aanduiding voor precieze en comfortabele berekening van de pupilafstand.

- Omschakeling van monoculaire naar binoculaire meting
- Helder fixatiepunt garandeert een gemakkelijk afleesbaar hoornvliesreflex
- Groot, gemakkelijk afleesbaar display met gelijktijdige aanduiding van gezamenlijke en enkel PD
- Omschakeling van PD meting naar HSA meting
- Vergrotingschuif

Technische specificaties

Aanduiding:	LC Display
Fixatie:	Lichtkruis
Meetbereik:	
Binoculair:	45,0 tot 82,0 mm in 0,5 mm stappen
Monoculair:	22,5 tot 41,0 mm in 0,5 mm stappen
Meetafstand kiesbaar tussen:	30, 35, 40, 50, 65 cm; 1,0, 2,0 m; ∞
Voeding:	2 x 1,5 V Mignon (type AA)
Afmetingen (B x H x D):	166 x 63 x 221 mm
Gewicht:	680 g

2387 00

12 maanden garantie!

Onderdelen verkrijgbaar bij uw leverancier.





Automatische lensmeter BS-4000 WF

- Hartmann sensortechnologie
- LCD kleuren touchscreen
- Automatische meting
- Automatische meting voor progressieve glazen
- Meting van de UV doorlaatbaarheid en PD
- Contactlenzenmodus
- Aanduiding van prisma resultaten
- Geïntegreerde Thermoprinter

2357 10

 12 maanden garantie!

 Onderdelen verkrijgbaar bij uw leverancier.

Exclusief bij B & S

Toebehoren voor BS-4000 WF

Kleurpatronen

- Voor niet gecoate en (**super**) hydrofobe brillenglazen
- Goed contrast bij het centreren en monteren van afnameblokken, speciaal bij getinte glazen

Wit

2357 60  3 stuks



Printerpapier

- Rolbreedte: 55 mm
- Roldiameter: 25 mm

2357 51  3 rollen

2357 52  10 rollen





Oculaire topsterktemeter

- Kantelbare behuizing
- Eenvoudig te bedienen
- Heldere, duidelijke markering
- Interne aflezing
- Inclusief prismacompensator
- Markering: inktkussen

Standaard uitvoering:

- 1 inktkussen, 1 x inkt, 1 stofkap

2355 20

 **12 maanden garantie!**

 **Onderdelen** verkrijgbaar bij uw leverancier.



Toebehoren voor Oculaire topsterktemeter

Inkt voor oculair SBM

2355 19

Technische specificaties voor beide modellen

Technische specificaties	2357 10 BS-4000 WF	2355 20 Oculaire
Meetbereik		
Sferisch:	- 25 tot + 25 dpt.	- 25 tot + 25 dpt.
Cilinder:	- 10 tot + 10 dpt.	- 25 tot + 25 dpt.
Asstand:	0° tot 180°	0° tot 180°
Additie:	0 tot 10 dpt.	alle in het meetbereik
Prisma's:	0 tot 15 Δ	0 tot 20 Δ
Meeteenheden		
Dioptrieën:	0,01/0,12/0,25 dpt.	0,125 dpt. tot ± 5,0 dpt. 0,25 dpt. tot ± 5,0 dpt.
Prisma's:	0,01/0,12/0,25 Δ	0,5 dpt. tot ± 2,0 dpt. 1,0 dpt. tot ± 2,0 dpt.
Prismalezing:	Cartesische en poolcoördinaten	Poolcoördinaten
Metingen		
Diafragma Ø 8 mm:	X	
Pupilaafstand 50 tot 86 mm (stappen van 0,5 mm):	X	
UV Transmissie 0 tot 100 % (375 nm):	X	
Meetobjecten enkelvoudige glazen:	X	X
Meetobjecten bifocale glazen:	X	X
Meetobjecten trifocale glazen:	X	X
Meetobjecten progressieve glazen:	X	
Meetobjecten contactlenzen:	X	
Display		
Kleuren touch-screen:	X	
Externe communicatie		
RS-232C seriële interface:	X	
Algemeen		
Thermoprinter:	X	
Vermogen:	25 W	35 W
Verbruik per 10 min:	0,0042 kWh	0,0058 kWh
Voltage:	240 V	240 V
Afmetingen (B x H x D):	161 x 372 x 222 mm	150 x 450 x 280 mm
Gewicht:	5,5 kg	4,9 kg

Ultrasoon OPTOSONIC! De professionele uitrusting van Duitse makelij.

Verbeterde resultaten

- Perfecte reiniging door aangepaste 37 kHz technologie
- Sweepfunctie voor optimale trilverdeling in de gehele kuip
- Ontgassingsfunctie voor een werkzame reiniging

Uitgebreide uitrusting

- Kuip van onverslijtbaar RVS – daardoor snelle, efficiënte en moeiteloze reiniging
- RVS behuizing, uiterst robuust en makkelijk te reinigen
- Geluidsisolerende deksel

Eenvoudige bediening

- Overzichtelijke, afgedichte bediening
- Draaiknop voor keuze reinigingstijd van 1–30 minuten
- LED aanduiding voor een snel overzicht

Ultrasoon OPTOSONIC Silence

- Een uitzonderlijk geluidsarme ultrasoon, geschikt voor in de winkel
- Efficiënte 80 kHz ultrasone prestaties
- Compacte en robuuste behuizing met 0,8 l kuipinhoud

2977 00

Technische specificaties	
Kuip (B x H x D):	190 x 60 x 85 mm
Kuipinhoud:	ca. 0,8 l
Frequentie:	80 kHz
Vermogen:	30 W
Verbruik per 10 min:	0,005 kWh
Voltage:	230 V
Buitenmaten (B x H x D):	206 x 178 x 116 mm
Gewicht:	2 kg
Beschikbare korf:	2971 02, 2974 10



36 maanden garantie!





Ultrasoon OPTOSONIC

- Compact toestel met 0,8 l kuipinhoud

2974 00

36 maanden garantie!

Onderdelen verkrijgbaar bij uw leverancier.



Ultrasoon OPTOSONIC

- Gebruiksvriendelijk apparaat met 2,8 l kuipinhoud
- Zijdelings aangebrachte draaiknop voor het eenvoudig afvoeren van de reinigingsvloeistof, via het uitloopventiel aan de achterkant van het apparaat
- Kunststof grepen
- Meer vermogen voor een nog betere reiniging

2975 00

36 maanden garantie!

Onderdelen verkrijgbaar bij uw leverancier.



Ultrasoon OPTOSONIC

Als Nr. 2975 00, met:

- Het reinigingsproces kan direct of temperatuurgestuurd gestart worden
- Inclusief verwarming en met droogloopbeveiliging
- Keuze van temperatuurstelling van 30 tot 80 °C in 5 stappen
- LED aanduiding van ingestelde en werkelijke vloeistoftemperatuur

2976 00

36 maanden garantie!

Onderdelen verkrijgbaar bij uw leverancier.



Technische specificaties	2974 00	2975 00	2976 00
Kuip (B x H x D):	190 x 60 x 85 mm	240 x 100 x 137 mm	240 x 100 x 137 mm
Kuipinhoud:	ca. 0,8 l	ca. 2,8 l	ca. 2,8 l
Frequentie:	37 kHz	37 kHz	37 kHz
Vermogen:	30 W	80 W	280 W, incl. 200 W voor ingebouwde verwarming
Verbruik per 10 min:	0,005 kWh	0,0133 kWh	0,0467 kWh
Voltage:	230 V	230 V	230 V
Buitenmaten (B x H x D):	206 x 178 x 116 mm	300 x 214 x 179 mm	300 x 214 x 179 mm
Gewicht:	2 kg	3,3 kg	3,3 kg
Beschikbare korf:	2971 02, 2974 10	2975 10	2975 10

Elmasonic P30H

- Multi frequentietechniek met 37/80 kHz
- 37 kHz voor standaard reiniging en 80 kHz voor reiniging met langere tijdsduur en daardoor nauwelijks waarneembaar
- Gebruiksvriendelijk apparaat met 2,8 l kuipinhoud
- Zijdelings aangebrachte draaiknop voor het eenvoudig afvoeren van de reinigingsvloeistof, via het uitlooptentiel aan de achterkant van het apparaat
- Kunststof grepen
- Meer vermogen voor een nog betere reiniging
- Het reinigingsproces kan direct of temperatuurgestuurd gestart worden
- Inclusief verwarming en met droogloopbeveiliging
- Keuze van temperatuurinstelling van 30 tot 80 °C in 5 stappen
- LED aanduiding van ingestelde en werkelijke vloeistoftemperatuur

2978 00



36 maanden garantie!



Onderdelen verkrijgbaar bij uw leverancier.

Technische specificaties	
Kuip (B x H x D):	240 x 100 x 137 mm
Kuipinhoud:	ca. 2,8 l
Frequentie:	37 kHz, 80 kHz
Vermogen:	350 W Incl. 320 W voor interne verwarming
Verbruik per 10 min:	0,0583 kWh
Voltage:	230 V
Buitenmaten (B x H x D):	300 x 214 x 179 mm
Gewicht:	3,3 kg
Beschikbare korf:	2975 10



Inbouw ultrasoon

- Nieuw compact apparaat: kuip en generator in één behuizing en aparte plaat met bedieningsschakelaar/timer
- Met geïntegreerde uitloop voor inbouw in werkblad of servicetafel
- Dezelfde techniek als Nr. 2974 00 (zie pagina A 9); bv duurzame sweep-functie voor optimale trilverdeling
- Optioneel verkrijgbaar: inbouw spoelbak Nr. 2970 11, zonder afvoer

2970 10



36 maanden garantie!



Onderdelen verkrijgbaar bij uw leverancier.

Technische specificaties	
Kuip (B x H x D):	190 x 60 x 85 mm
Kuipinhoud:	ca. 0,8 l
Frequentie:	37 kHz
Vermogen:	30 W
Verbruik per 10 min:	0,005 kWh
Voltage:	230 V
Buitenmaten (B x H x D):	206 x 178 x 116 mm
Gewicht:	2 kg
Beschikbare korf:	2974 10





Toebehoren

Spoelbak voor 2970 10

Zonder uitloop.

2970 11

190 x 75 x 85 mm

740 g



Metalen korf

Passend op ultrasoons Nr. 2970 10, 2974 00 en 2977 00.

2974 10

177 x 35 x 74 mm zonder grepen 211 g



Metalen korf

Passend op ultrasoons Nr. 2975 00, 2976 00 en 2978 00.

2975 10

200 x 55 x 107 mm zonder grepen 400 g



Kunststof roosterkorf

Passend op ultrasoons Nr. 2970 10, 2974 00 en 2977 00.

2971 02

185 x 47 x 85 mm 49 g



OPTOCLEAN en reinigingsconcentraat
vindt u op pagina E 19.

Een must voor alle opticiens die waarde hechten aan comfortabel werken en die goed design waarderen.

Het apparaat is uitermate geschikt voor in de winkel. De OPTIFORMA kan ook in de werktafel verzonken worden. Wanneer het montuur geruisloos verwarmd wordt, kunt u ongestoord uw verkoopgesprek vervolgen. Met de gedigitaliseerde temperatuurregeling voor veilige werking, is dit toestel bovendien een voorbeeld van een echt kwaliteitsproduct van Duitse makelij.



OPTIFORMA Profi

- Geluidsarm
- Traploze temperatuur- en looptijdaanduiding via LC waarden en toetsen
- Menugestuurde bediening dmv tekstdisplay
- Ingebouwde bescherming tegen oververhitting
- Automatische uitschakeling bij overhellen
- Automatische afkoelingsfase
- Inbouwbaarheid in werkblad of servicetafel, inbouwdiepte: 145 mm
- Inclusief inbouwsjablonen voor werkbladen tot max. 28 mm dik
- Afstand tussen de verwarmingselementen: 45 mm
- Opzet voor puntverwarming

 Zwart/Grijs

2872 01

Inbouwsjablonen voor OPTIFORMA-Profi Nr. 2872 ..

2872 25

Technische specificaties

Temperatuurregeling:	60 tot 140 °C
Instelbare looptijd:	50 tot 249 s
Hittebeveiliging door thermoschakelaar	
Vermogen:	800 W
Verbruik per 10 min:	0,1333 kWh
Voltage:	230 V
Afmetingen (B x H x D):	230 x 228 x 275 mm
Gewicht:	2,1 kg

 **36 maanden garantie!**

 **Onderdelen** verkrijgbaar bij uw leverancier.



- Design-Zentrum Nordrhein-Westfalen

Designinnovaties
Onderscheiding voor
hoge designkwaliteit



OPTIFORMA Standaard

- Traploze temperatuurregeling via potentiometer
- Opzet voor puntverwarming
- Automatische uitschakeling bij overhellen
- Hittebeveiliging
- Afstand tussen de verwarmingselementen: 45 mm

 Zwart/Grijs

2871 01

Technische specificaties	
Temperatuurregeling:	80 tot 140 °C
Hittebeveiliging door thermoschakelaar	
Vermogen:	800 W
Verbruik per 10 min:	0,1333 kWh
Voltage:	230 V
Afmetingen (B x H x D):	170 x 228 x 190 mm
Gewicht:	1,5 kg

 **36 maanden garantie!**

 **Onderdelen** verkrijgbaar bij uw leverancier.

De geoptimaliseerde klassieker

In samenwerking met de TU Aalen (Did) werd een studie gemaakt inzake optimale warmteverdeling en toegepast in deze nieuwe generatie OPTIMONSUN.

Dit merkproduct uit Duitsland voldoet aan de hoogste eisen. Bij de elektronische uitvoering is een derde programma toegevoegd die voor hout en hoorn materiaal hogere temperaturen vereist. (180–230 °C).

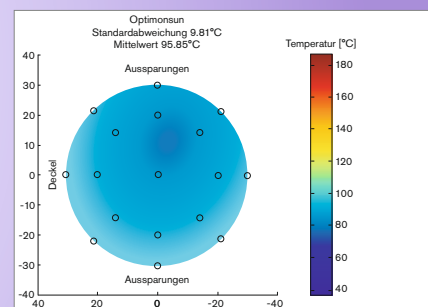
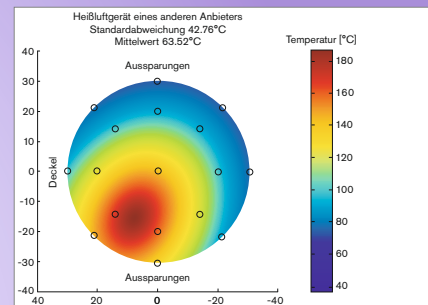

Design Föhn OPTIMONSUN

- Nieuw designapparaat met zeer gelijkmatige temperatuurverdeling in de beker
- Comfortabele hantering van het montuur door optimale openingen in de beker
- Hittebeveiliging
- Kunststof beker 85 Ø, openingen breed 30 mm, diep 34 mm
- Inclusief inzetbare puntverwarming
- 2,5 m spiraalsnoer (2 m normaal snoer bij inbouw uitvoering)



2865 00
Wit



2865 01
Zwart
Metallic



2865 02
Grijs
Metallic



2865 03
Blauw

2865 ..

Design Föhn OPTIMONSUN Electronic

Technisch gelijk aan 2865 .. , maar extra:

- Bewegingssensor voor een comfortabele bediening
- 3 programma's: (continu, 10 min, hoorn materiaal tot 230 °C)
- Constante elektronische temperatuurregeling, regelbaar
- Automatische uitschakeling na 3 uur
- Inclusief puntverwarming



2866 00
Wit



2866 01
Zwart
Metallic



2866 02
Grijs
Metallic



2866 03
Blauw

2866 ..

Technische specificaties	2865 ..	2866 ..
Temperatuur:	180 °C	min. 60 °C, max. 230 °C
Temperatuur met opzetverwarming:	max. 200 °C	max. 240 °C
Temperatuurregeling:	neen	in 10° stappen
Vermogen:	155 W	300 W
Verbruik per 10 min:	0,0258 kWh	0,0499 kWh
Voltage:	230 V	230 V
Afmetingen (B x H x D):	190 x 265 x 190 mm	190 x 265 x 190 mm
Gewicht:	1,7 kg	1,7 kg

36 maanden garantie!

Onderdelen verkrijgbaar bij uw leverancier.



2867 ..

Föhn OPTIMONSUN

- Compleet met beker 85 mm Ø, opening 30 mm, diep 20 mm
- **Zonder** temperatuurregeling
- Metalen behuizing
- 2 m spiraalsnoer

2867 ..



36 maanden garantie!



Onderdelen verkrijgbaar bij uw leverancier.



2867 01
Zwart
Metallic



2867 10
Grijs
Metallic



2867 15
Blauw



2867 22
Wit

Föhn OPTIMONSUN Electronic

Technisch gelijk aan 2867 .. , maar extra:

- Constante elektronische temperatuurregeling, traploos regelbaar

2869 ..



36 maanden garantie!



Onderdelen verkrijgbaar bij uw leverancier.



2869 01
Zwart
Metallic



2869 10
Grijs
Metallic



2869 15
Blauw



2869 22
Wit

2869 ..



Technische specificaties	2867 ..	2869 ..
Temperatuur:	max. 180 °C	min. 65 °C, max. 180 °C
Temperatuur bij puntverwarming:	max. 200 °C	max. 200 °C
Temperatuurregeling:	neen	traploos regelbaar
Vermogen:	215 W	250 W
Verbruik per 10 min:	0,0358 kWh	0,0417 kWh
Voltage:	230 V	230 V
Afmetingen (B x H x D):	100 x 250 x 160 mm	100 x 250 x 160 mm
Gewicht:	1,3 kg	1,7 kg

Föhn Fata up Plus/Fata Up

- De stille en krachtige hulp bij het afstellen van brillen
- Zeer licht en geluidsarm apparaat met en zonder temperatuurregeling
- Inclusief puntverwarming

Fata up Plus (met temperatuurregeling)

Wit Zwart

2878 00

2878 01

Fata up (zonder temperatuurregeling)

Wit Zwart

2878 10

2878 11



Technische specificaties

Temperatuur:	0-150 °C
Vermogen:	350 W
Verbruik per 10 min:	0,0583 kWh
Voltage:	230 V
Afmetingen (B x H x D):	120 x 320 x 180 mm
Gewicht:	1,9 kg

 **60 maanden garantie!**

 **Onderdelen** verkrijgbaar bij uw leverancier.

Föhn Zita Plus

- Constante elektronische temperatuurregeling
- Traploos regelbaar
- Afstand tussen de verwarmingselementen: 35 mm
- Inclusief inzetbare puntverwarming
- Metaal behuizing

2875 00

Technische specificaties

Temperatuurstand I:	tot 75 °C
Temperatuurstand II:	tot 150 °C
Vermogen:	900 W
Verbruik per 10 min:	0,1499 kWh
Voltage:	230 V
Afmetingen (B x H x D):	144 x 213 x 200 mm
Gewicht:	1,46 kg

 **60 maanden garantie!**

 **Onderdelen** verkrijgbaar bij uw leverancier.





Föhn Maga S

- Zeer duurzaam werkplaatsapparaat. Met tweezijdige verwarming
- Twee elektronische temperatuurstanden
- Afstand tussen de verwarmingselementen: 45 mm
- Inclusief inzetbare puntverwarming
- Metalen behuizing

2876 00

Technische specificaties	
Temperatuurstand I:	tot 75 °C
Temperatuurstand II:	tot 150 °C
Vermogen:	1.500 W
Verbruik per 10 min:	0,2499 kW
Voltage:	230 V
Afmetingen (B x H x D):	190 x 215 x 315 mm
Gewicht:	3 kg

 **60 maanden garantie!**

 **Onderdelen** verkrijgbaar bij uw leverancier.



VENTILETTE Model 3

- Compleet met beker 80 mm Ø, opening 30 mm
- Behuizing en voet van aluminium
- Motor rubber gelagerd, daardoor rustige loop
- Universele motor voor wisselstroom (AC) en gelijkstroom (DC)
- Extra lange koolborstels voor verlenging van de looptijd
- Met warm/koud schakelaar

2861 22



VENTILETTE Modell 3, Electronic

- Als Nr. 2861 22, maar met traploos regelbaar temperatuurbereik

2861 42



Technische specificaties	2861 22	2861 42
Temperatuurbereik:	tot max. 160 °C	van 40 tot 200 °C (traploos regelbaar)
Vermogen:	450 W	800 W
Verbruik per 10 min:	0,0749 kWh	0,1333 kWh
Voltage:	230 V	230 V
Afmetingen (B x H x D):	275 x 135 x 145 (Ø voet) mm	275 x 135 x 145 (Ø voet) mm
Gewicht:	1,3 kg	1,6 kg

 **36 maanden garantie!**

 **Onderdelen** verkrijgbaar bij uw leverancier.

Het origineel uit Japan is uniek:

Hoogwaardige materialen, zoals messing busen en lagers, evenals beproefde motortechnologie geven deze „compacte Japanner“ ook in duurloop grote betrouwbaarheid en lange levensduur. Bijzonder geschikt voor regelmatig gebruik. Beslissende redenen voor ons, om dit origineel uit Japan aan te bevelen.



TAKUBOMATIC Groefmachine

- Grote, speciaal gelagerde aandrijfrollen maken ook het groeven op moeilijke glasvormen mogelijk
- Traploos instelbare groefdiepte
- Groeven parallel aan achterzijde mogelijk
- Keuze uit 4 verschillende aandrijfmogelijkheden:
 - Aangestuurd groefverloop parallel aan voor- en achterzijde mogelijk
 - Vrijlopend groefverloop
 - Handmatige besturin
- Geen aanpassing aan de glascurve nodig
- Door eenvoudig ombouwen met Nr. 2893 20 kan er ook voor leesbrillen worden gewerkt
- Incl. standaard groefschijf (0,55 mm) en leesbrillenadapter

2894 00N

Technische specificaties

Groefdiepte:	0 tot 0,7 mm
Groefbreedte:	0,55 mm
Dikte glasrand:	(min.) 1,5 tot (max.) 11 mm
Glasdiameter:	(min.) 25 tot (max.) 70 mm
Rotatietijd (brillenglas):	ca. 40 s/glas
Vermogen:	57 W
Verbruik per 10 min:	0,0095 kWh
Voltage:	230 V
Afmetingen (B x H x D):	170 x 160 x 210 mm
Gewicht:	2,7 kg

36 maanden garantie!

Onderdelen verkrijgbaar bij uw leverancier.



Grote, speciaal gelagerde aandrijfrollen maken ook het groeven op moeilijke glasvormen mogelijk



Tegen spatwater beschermde kogellagers, daardoor langere levensduur



Zachte siliconen zorgen voor een goede grip op de glazen en een gelijkmatige drukverdeling bij het klemmen



Beide glasvoorzieningen hebben elk een fijnjusteerbare kunststof rol voor de exacte positionering boven de groefschijf

Onderdelen voor Nr. 2894 00 N en 2894 00 (uitverkocht)

Voor 2894 00 N	Voor 2894 00	Omschrijving
2893 05 N	2893 05	Afdekkap voor diamantschijf 0,55 mm
2893 06	2893 06	Aandrijfriem voor de as van de diamantschijf
2893 09	2893 09	Geleidestift met veer
2893 10	2893 10	Kogellager voor de aandrijf-as van de diamantschijf
2893 13	2893 13	Centreerpen
2893 14	2893 14	Geleiderubber wit voor brillenadapter groot
2893 15	2893 15	Leesbrillenadapter klein
2893 26	2893 26	Geleiderubber voor leesbrillenadapter klein
2894 04 N	2894 04	Afdekkap voor diamantschijf 1,20 mm
2894 06	2894 06	Spangreep rechts compleet
2894 29	2894 29	Schroef voor diamantschijf
-	2894 43	Draaiknop voor spangreep rechts voor oude apparaten tot serienummer 279 72
2894 51 N	2894 51	Geleidehendel links en rechts compleet
2894 52 N	2894 52	Geleidehendel links compleet
2894 53 N	2894 53	Geleidehendel rechts compleet
2894 54 N	2894 54	Geleiderol links
2894 55 N	2894 55	Geleiderol rechts

Groefmachine

- Grote aandrijfrollen voor het groeven op moeilijke glasvormen
- Instelbare groefdiepte
- Groeven parallel aan achterzijde mogelijk
- Keuze uit 4 aandrijfmogelijkheden:
 - Aangestuurd groefverloop parallel aan voor- en achterzijde mogelijk
 - Vrijlopend groefverloop
 - Handmatige besturin
- Geen aanpassing aan de glascurve nodig
- Incl. standaard groefschijf Nr. 2898 33 (0,55 mm)

2899 00 N



Technische specificaties

Groefdiepte:	0 tot 0,7 mm
Groefbreedte:	0,55 mm
Glasdikte:	1,5 tot max. 11 mm
Minimale afmeting vlakke vorm met afgeronde hoeken:	22 x 56 mm
Rotatietijd (brillenglas):	ca. 40 s/glas
Vermogen:	100 W
Verbruik per 10 min:	0,0167 kWh
Voltage:	220 V
Afmetingen (B x H x D):	170 x 152 x 220 mm
Gewicht:	2,9 kg

 36 maanden garantie!

 Onderdelen verkrijgbaar bij uw leverancier.



Onderdelen voor Nr. 2899 00 N

Voor 2899 00 N	Voor 2899 00	Omschrijving
2898 13	2898 13	Draaiknop voor spangreep rechts met schroef
2898 14	2898 14	Spangreep rechts compleet
2898 23	2898 23	Kogellager voor aandrijfjas
2898 24	2898 24	Aandrijfriem
2899 01 N	2899 01	Groeftafel compleet
2899 03 N	2899 03	Afdekkap voor diamantschijf 0,55 mm
2899 10 N	-	Afdekkap voor diamantschijf 1,05/1,20 mm
2899 19 N	-	Geleiderol link
2899 20 N	-	Geleiderol rechts



Gebruiksmateriaal en toebehoren voor groefmachines

Een kleinigheid maakt het verschil:

De in Frankrijk gemaakte groefschijven met speciaal gesinterde diamantcoating bieden zeer lange looptijden.

Een centrische asopname garandeert een precisieloop. Zo uitgerust kan de B&S groefmachine optimaal voor u aan het werk. Daar loont de investering dus dubbel.



Diamantschijf

- Speciaal voor polycarbonaat
- Voor groefbreedte: 0,55 mm
- Buitendiameter: 25 mm
- Geschikt voor Nr. 2894 00, 2894 00N, 2898 00, 2899 00 en 2899 00N



2894 58

- Voor groefbreedte: 0,55 mm
- Buitendiameter: 25 mm
- Geschikt voor Nr. 2894 00, 2894 00N, 2898 00, 2899 00 en 2899 00N



2893 01

- Voor groefbreedte: 1,05 mm
- Buitendiameter: 25 mm
- Geschikt voor Nr. 2894 00, 2894 00N, 2898 00, 2899 00 en 2899 00N



2893 18

- Voor groefbreedte: 1,23 mm
- Buitendiameter: 25 mm
- Geschikt voor Nr. 2894 00, 2894 00N, 2898 00, 2899 00 en 2899 00N



2894 03

Diamantschijf

- Voor groefbreedte: 0,55 mm
- Buitendiameter: 25 mm
- Geschikt voor Nr. 2894 00, 2894 00N, 2898 00, 2899 00 en 2899 00N



2898 33

Leesbrillenadapter

- Geschikt voor Nr. 2894 00 en 2894 00N



2893 15  1 paar

Adapterset voor lenti voor Nr. 2894 00N

- Bestaat uit diamantschijf Nr. 2893 21 en legtafel Nr. 2893 25
- Mogelijke randreductie: 2 mm
- Geschikt voor Nr. 2894 00 en 2894 00N



2893 20  230 g

Diamantschijf

- Voor lenti
- Als reserveonderdeel voor adapterset Nr. 2893 20



2893 21

Handslijpsteen V- facet

- Fijne vlakken met V- facet
- Compacte en robuuste kunststof behuizing
- Keuzeschakelaar voor looprichting
- 34 mm brede diamantschijf met V- facet

2927 10

Technische specificaties	
Toerental:	2.800 tpm
Afmetingen diamantschijf:	Ø 100 mm, breedte 34 mm
Korreldikte:	2,5 mm
Vermogen:	75 W
Verbruik per 10 min:	0,0125 kWh
Voltage:	220–240 V
Afmetingen (B x H x D):	180 x 180 x 260 mm
Gewicht:	5 kg

 **12 maanden garantie!**

 **Onderdelen** verkrijgbaar bij uw leverancier.



Handslijpsteen met sensor

- Fijne en ruwe oppervlakken met V- facet
- **Met infrarood sensor** voor comfortabel werken
- Compacte en robuuste kunststof behuizing
- Keuzeschakelaar voor rotatie vooruit en achteruit
- 35 mm brede diamantschijf met V-facet

2928 10

Technische specificaties	
Toerental:	2.000 tpm
Afmetingen diamantschijf:	Ø 100 mm, breedte 35 mm
Korreldikte:	2 mm
Vermogen:	150 W
Verbruik per 10 min:	0,0249 kWh
Voltage:	220–240 V
Afmetingen (B x H x D):	225 x 175 x 360 mm
Gewicht:	7,5 kg

 **12 maanden garantie!**

 **Onderdelen** verkrijgbaar bij uw leverancier.



Handslijpsteen

- Fijnslijpen met V-facet
- Compacte en robuuste kunststof behuizing
- Keuzeschakelaar voor rotatie vooruit en achteruit
- 35 mm brede diamantschijf met V-facet

2928 00

Technische specificaties	
Toerental:	2.000 tpm
Afmetingen diamantschijf:	Ø 100 mm, breedte 35 mm
Korreldikte:	2 mm
Vermogen:	150 W
Verbruik per 10 min:	0,0249 kWh
Voltage:	220–240 V
Afmetingen (B x H x D):	225 x 275 x 360 mm
Gewicht:	7,5 kg

 **12 maanden garantie!**

 **Onderdelen** verkrijgbaar bij uw leverancier.





Origineel gemaakt in Japan

De klassieke handslijpsteen met ongeëvenaarde levensduur en uiterst hoge belastbaarheid. De hoogwaardige diamantschijven zijn met precisie vervaardigd, om een rustige, gelijkmatige loop te garanderen. Een betrouwbare hulp in uw werkplaats!

TAKUBOMATIC handslijpsteen in 2 versies

- Keuzeschakelaar vooruit en achteruit
- Goede kwaliteit diamantschijf 30 mm breed, verkrijgbaar in verschillende versies, allen voor lang gebruik



Technische specificaties	
Toerental:	1.800 tpm
Afmetingen diamantschijf:	Ø 100 mm, breedte van 30 tot 32 mm
Korrel-dikte:	1,2 mm
Vermogen:	97 W
Verbruik per 10 min:	0,0162 kW
Voltage:	230 V
Afmetingen (B x H x D):	220 x 280 x 360 mm
Gewicht:	8 kg

36 maanden garantie!

Onderdelen verkrijgbaar bij uw leverancier.

Handslijpsteen

Uitvoering met diamantschijf
Fijnslijp met facet en afgeronde kant

2923 00

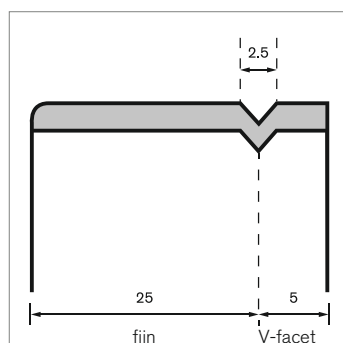

Handslijpsteen

Uitvoering met diamantschijf
Fijn- en voorslijp met facet

2925 00

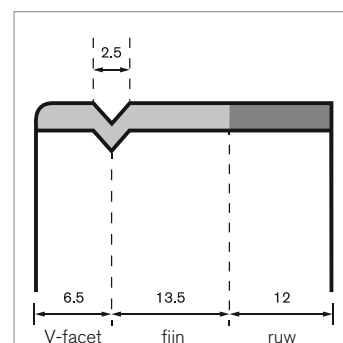

Het „werkpaard” in een nieuw design

Een polijstmotor „Made in Germany” waar lang naar gezocht is en die aan al onze eisen voldoet. Traploze regeling van de snelheid van links- en rechtsloop en sterke doorloopkracht. Lage begintoeren maken het mogelijk zonder problemen tere materialen zoals polycarbonaat te polijsten. Een optionele buigzame slang vergroot de mogelijkheden. Wie effectief en efficiënt wil polijsten, zet in op deze alleskunner.



B & S Polijstmotor met L/R loop

- Frequentiegestuurde 3 fasen motor
- Links- en rechtsloop
- Onderhoudsarme kogellagers
- Geluidsarm
- 300 W
- Geschikt voor langdurig gebruik
- Inclusief linker en rechter polijstspits

2967 00

Technische specificaties

Toerental:	0 tot 6000 tpm (traploos regelbaar)
Ashoogte:	111 mm
Vermogen:	300 W
Verbruik per 10 min:	0,0499 kWh
Voltage:	230 V
Afmetingen (B x H x D):	250 x 170 x 172 mm
Gewicht:	11 kg

 36 maanden garantie!

 Onderdelen verkrijgbaar bij uw leverancier.



Reserve polijstspitsen voor polijstmotoren Nr. 2967 00 en 2966 00 (uitverkocht)

Polijstspits, links

Met rechtsdraaiend schroefdraad.

2966 22

∅ 14 mm (Boring)

ca. 115 mm



Polijstspits, rechts

Met linksdraaiend schroefdraad.

2966 23

∅ 10 mm (Boring)

ca. 115 mm



Bij de aankoop van polijstspitsen: Multifixhendel in stand **rechtsloop (schijf draait naar u toe)**:
Links: polijstspits Nr. 2966 22 – Rechts: polijstspits Nr. 2966 23

LUX Polijstmotor

- Met 2 conische spitsen (rechts- en linksdraaiend schroefdraad) en schijvenspoel
- 2 verschillende snelheden
- Niet voor langdurig gebruik geschikt (max. 20 min)

2968 00



Polijstschijven en polijstmiddelen vindt u vanaf pagina E 27.

Technische specificaties

Toerental:	1.400 en 2.800 tpm
Vermogen:	300 W
Verbruik per 10 min:	0,0499 kWh
Voltage:	230 V
Afmetingen (B x H x D):	250 x 300 x 150 mm
Gewicht:	5,5 kg



36 maanden garantie!



Onderdelen verkrijgbaar bij uw leverancier.

Universele stofkap voor links en rechts

- Metalen behuizing met uitneembare kunststof kuip

2968 20

Technische specificaties

Afmetingen (B x H x D):	185 x 280 x 270 mm
Gewicht:	2,75 kg



Glasboormachine automatisch

Om te boren en te frezen

- Gemakkelijk en snel vaststellen van de boorgatcoördinaten aan de hand van bestaande glazen of demo lenzen
- Opslaan van de boorgatcoördinaten van de op dat moment afgetaste glasbril
- **De opgeslagen coördinaten worden automatisch na elkaar aangeleverd en functioneert voor elk boorgat automatisch**
- Zeer goede resultaten in korte tijd

Inclusief:

- Markeerhulp Nr. 2889 01
- Boren (1,0; 1,2; 1,4; 1,5; 1,6; 1,7; 2,0)
- Frezen (0,8; 1,1; 1,2; 1,4)
- Boorfreeset Nr. 2035 50

2890 30

Technische specificaties

Toerental:	0 tot 3.000 tpm
Vermogen:	50 W
Verbruik per 10 min:	0,0083 kWh
Voltage:	230 V
Afmetingen (B x H x D):	300 x 225 x 270 mm
Gewicht:	5 kg

 12 maanden garantie!

 Onderdelen verkrijgbaar bij uw leverancier.

Markeerhulp

2889 01



Boren en frezen
(zie pagina C 32)

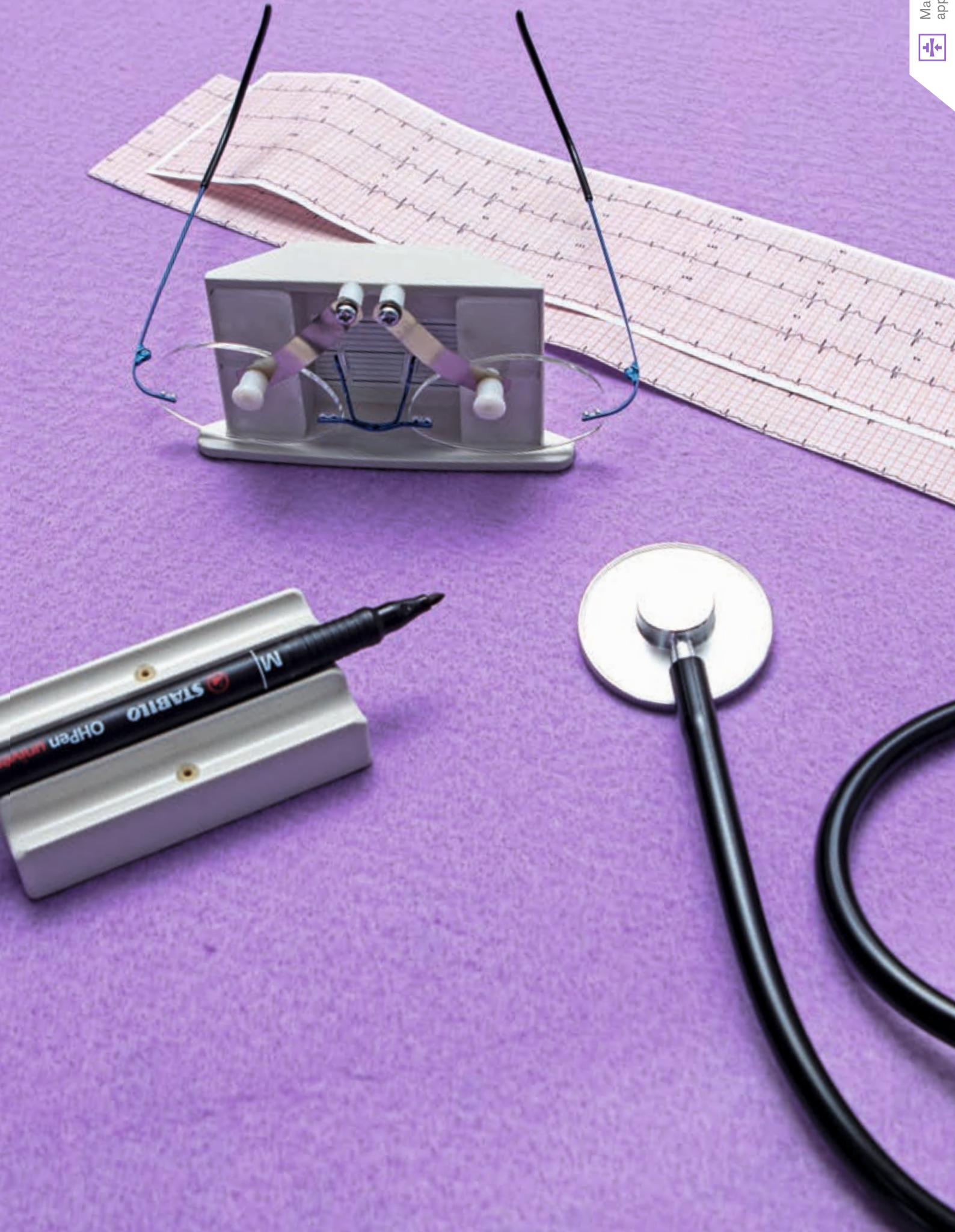

Boorcentrum

Boren, frezen, kerven, aan alle eisen die moderne glasbrillen vragen wordt met dit voordelige boorcentrum probleemloos voldaan.

- Boren, frezen en kerven inclusief afnameblokken mogelijk
- Als hand- en standboormachine te gebruiken
- Lichtgewicht, handzaam tafelapparaat
- Bergruimte voor boren, frezen en accessoires
- Kruistafel met verstelbare millimeterschaal, ook los verkrijgbaar: Nr. 2191 11
- Optimale boorrichtingen mogelijk door draaien van het glas
- Boren met het in acht nemen van de inclinatie is ideaal door de instelbare meetschaal

2191 06

Inclusief adapter voor WECO afnameblokken (ook te gebruiken zonder blocker)



Glasboorvoorziening voor NIDEK varioblok (zonder afbeelding)

Geschikt voor Xenox- en Proxon-kruistafels. Compleet met NIDEK-afnameblokken.

2891 64-NIDEK

Technische specificaties

Toerental:	5.000 tot 20.000 tpm (traploos regelbaar)
Spanbereik boorhouder:	0,5 tot 3,2 mm
Oppervlak kruistafel:	200 x 70 mm
Verstelbereik kruistafel:	X (schuin) 134 mm, Y (diep) 46 mm
Vermogen:	60 W
Verbruik per 10 min:	0,0099 kWh
Aansluiting:	230 V
Spanning:	12 V
Afmetingen zonder netaansluiting (B x H x D):	280 x 400 x 330 mm
Gewicht:	2,8 kg

36 maanden garantie!

Onderdelen verkrijgbaar bij uw leverancier.



Afnameblokken en onderdelen verkrijgbaar bij uw leverancier.



Xenox Tafelboormachine

- Maatprecisie dmv diepteschaalverdeling
- Verstelbare aanduiding met diepteschaalverdeling
- Werking dmv aandrijfriemen
- Zéér geluidsarm
- Incl. bankschroef Nr. 2887 21
- Incl. boorhouder Nr. 2887 11
- 6 stalen spantangen voor schachten 0,8 tot 3,2 mm
- **Toebehoren:** Bodemplaat Nr. 2887 14, kruistafel Nr. 2191 11 en ondersteuning Nr. 2191 15

2887 55

Als Nr. 2887 55, maar **zonder** toebehoren.

2887 20



Technische specificaties

Toerentallen:	1.800 en 4.700 en 8.500 tpm (dmv het omleggen van de aandrijfriemen)
Vermogen:	85 W
Verbruik per 10 min:	0,0142 kWh
Voltage:	230 V
Afmetingen (B x H x D):	120 x 330 x 220 mm
Gewicht:	5,7 kg

 **36 maanden garantie!**

 **Onderdelen** verkrijgbaar bij uw leverancier.



Praktische boordiepte-aanduiding met instelbare aanslag

Proxxon Boorstander

- Boorkop tot 90° draaibaar voor schuin boren en multifunctioneel frezen
- Met gevoelige verschuiving via stelwiel en rollagers
- Massieve, verchroomde stalen zuil (Ø 20 mm, 280 mm hoog)
- Opname boormachine aan beide zijden tot 90° draaibaar
- Gewicht: 2 kg

Boormachine Nr. 2886 61 en bankschroef Nr. 2887 21 zijn niet bij de levering inbegrepen.

2128 65

 **36 maanden garantie!**

 **Onderdelen** verkrijgbaar bij uw leverancier.



Machine-bankschroef

Voor tafelboormachine Nr. 2887 20 en boorstander Nr. 2128 70 (uitverkocht).

2887 21



Xenox Boor- en freesmachine

Incl. 6 spantangen met diameter 1,0; 1,5; 2,0; 2,4; 3,0 en 3,2 mm en boorhouder Nr. 2886 64.

Levering zonder afgebeelde slijp en polijstschijven.

2886 61



Technische specificaties	
Toerental:	5.000 tot 20.000 tpm
Vermogen:	60 W
Verbruik per 10 min:	0,0099 kWh
Voltage:	230 V
Afmetingen (B x H x D):	240 x 90 x 240 mm
Gewicht:	2,9 kg

 **36 maanden garantie!**

 **Onderdelen verkrijgbaar bij uw leverancier.**

Proxxon Handboormachine met trafo

Incl. 6 spantangen met diameter 1,0; 1,5; 2,0; 2,4; 3,0 en 3,2 mm.

2886 60



Technische specificaties	
Toerental:	5.000 tot 20.000 tpm (traploos regelbaar)
Vermogen:	60 W
Verbruik per 10 min:	0,0099 kWh
Voltage:	230 V
Afmetingen (B x H x D):	140 x 80 x 240 mm
Gewicht:	2,9 kg

 **36 maanden garantie!**

 **Onderdelen verkrijgbaar bij uw leverancier.**



Onze precisie gereedschappen vindt u vanaf pagina C 31.



Top kwaliteit

Het AQUARIUS Hydrozon apparaat wordt door een kleine firma in Duitsland onder inachtneming van de hoogste kwaliteitseisen gemaakt. Hydrozon soldeertechniek minimaliseert schadelijke oxidatie tijdens het solderen en maakt zo een materiaalsparende reparatie mogelijk. De milieuvriendelijke techniek gebruikt jarenlang bijna geen verbruiksmateriaal en is daarom op lange termijn zeer kostenbesparend. Daarom garanderen wij jarenlange service op eventuele reparaties en reserveonderdelen.



AQUARIUS Soldeer- en lasapparaat

- Voor langdurig gebruik geschikt
- Met drukbegrenzer en terugslagzekering in het handstuk
- Fijnregeling van de vlam d.m.v. wielje aan handstuk en verschillende naalden
- Optisch display drukknop met LCD
- Met geïntegreerde vloeistoftanks
- **Inclusief accessoires (elk 1x):**
Stander voor soldeerhandstuk Nr. 2845 00, soldeerhandstuk Nr. 2846 00, vulstanddrijvers Nr. 2847 00 en 2847 01, elektrolyt Nr. 3198 00 en methanol Nr. 3199 01

2839 60

AQUARIUS Soldeer- en lasapparaat

- Als Nr. 2839 60, maar met max. gascapaciteit 50 l/u
- Er kan optioneel met 2 werkstations gewerkt worden
- **Inclusief accessoires (elk 1x):**
Stander voor soldeerhandstuk Nr. 2845 00, soldeerhandstuk Nr. 2846 00, vulstanddrijvers Nr. 2847 00 en 2847 01, soldeer-naaldenset Nr. 2840 50, elektrolyt Nr. 3198 00 en methanol Nr. 3199 01

2839 00

Technische specificaties	2839 60	2839 00
Aantal werkstations:	1	2
Max. capaciteit gas:	45 l/h	50 l/h
WATERVERBRUIK:	16 g/h	28 g/h
Vloeistofverbruik:	6 g/h	8 g/h
Grootst bruikbare naald:	20 G (0,9 mm)	19 G (1,0 mm)
Opname:	200 W	250 W
Verbruik per 10 min:	0,0333 kWh	0,0417 kWh
Voltage:	230 V	230 V
Afmeting apparaat zonder opbouw (B x H x D):	450 x 280 x 220 mm	450 x 280 x 220 mm
Gewicht (bedrijfsklaar):	14 kg	17 kg

42 maanden garantie en 20 jaar onderdelen leverbaar!

Onderdelen verkrijgbaar bij uw leverancier.

Micro-Torch II+ Complete set met centraal doseerventiel

- Praktische soldeerunit, gemakkelijk en ruimtebesparend
- Met centraal doseerventiel voor een snelle vlamregeling
- **Bij levering inbegrepen:**
2 zuurstofflessen Nr. 2760 02, branderhandstuk Nr. 2761 01, gasfles Nr. 2761 06, Triox adapter met doseerventiel Nr. 2762 06 en soldeernaalden Nr. 2840 06, 2840 08, 2840 10 en 2840 13

2762 05



 **Onderdelen** verkrijgbaar bij uw leverancier.



Overeenkomstig de wettelijke voorschriften worden zuurstof en gas in afzonderlijke verpakking geleverd.

Micro Soldeer- en lasapparaat

- Klein, handzaam apparaat om te solderen
- Piezo ontsteking
- Speciale brander met luchttoevoer zorgt voor een kleine puntige 1.600 °C hete vlam
- Gebruiksklare levering met 1 fles Nr. 2761 06

2763 00  160 g



Soldeerbout

- Vernikkelde koperen punt, recht
- Inclusief stander

2770 00  200 g



Technische specificaties

Vermogen:	25 W
Verbruik per 10 min:	0,0042 kWh
Spanning:	230 V
Temperatuur:	max. 420 °C
Opwarmtijd:	2 min
Snoerlengte:	1,5 m
Diameter:	4 mm

 **Onderdelen** verkrijgbaar bij uw leverancier.

Pons met gegroefde kop passend bij Nr. 2770 00:

2770 10 **Pons met gegroefde kop** Binnenmaat: 3 mm



2770 11 **Pons met gegroefde kop** Binnenmaat: 1,8 mm





De klassieker „Made in Germany”

Sinds decennia beproefd en daarom bijna niet veranderd. Betrouwbare hulp met vaste „hand”.

Soldeertafel

- Ideaal voor het fixeren van een gebroken montuur bij het lassen
- 2 beweegbare klemmen, verticaal en horizontaal verstelbaar en vast te zetten
- Montage van een derde klem mogelijk
- Bodemplaat hittebestendig
- Afmetingen bodemplaat (B x D): 295 x 210 mm

2757 00

 2,1 kg

 **Onderdelen** verkrijgbaar bij uw leverancier.



Soldeertafel met kleine bodemplaat

- Ideaal voor het fixeren van werkstukken
- Met drie beweegbare klemmen
- Klemmen horizontaal en verticaal te verstellen en vast te zetten
- Kleine plaatsbesparende bodemplaat
- Fixatiemogelijkheid voor een derde klem op de bodemplaat
- Materiaal: messing verchroomd edelstaal
- Afmetingen bodemplaat (B x D): 100 x 100 mm

2757 20

 1,4 kg

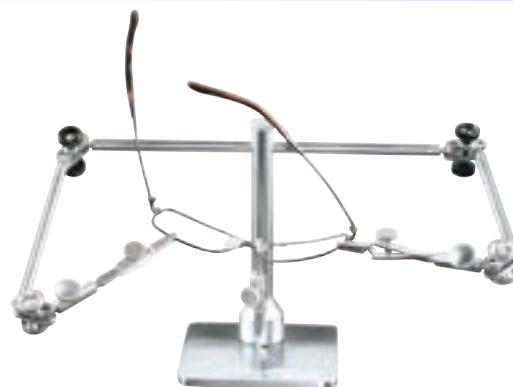

Toebehoren voor soldeerapparaat Nr. 2762 05 en voor AQUARIUS soldeeren lasapparaten

Soldeernaalden

2840 ..

Gauge*- Beschrijving	Naald Ø	Opening Ø	Bestelnr.
24	0,5 mm	4,0 mm	2840 05
23	0,6 mm	4,0 mm	2840 06
22	0,7 mm	4,0 mm	2840 07
21	0,8 mm	4,0 mm	2840 08
20	0,9 mm	4,0 mm	2840 09
19	1,0 mm	4,0 mm	2840 10
18	1,2 mm	4,0 mm	2840 13



* Met Gauge wordt een meeteenheid aangeduid waarmee men de opening van naalden en canules meet. Hoe hoger de Gaugewaarde des te geringer de afmeting.

Soldeernaaldenset

5 stuks gesorteerd.
Soldeernaalden Ø: 0,6; 0,7; 0,8; 0,9 en 1,0 mm

2840 50



Onze soldeertoehoren vindt u op pagina E 34 t/m E 37.

Ruimers voor soldeernaalden

Met kunststofgreep, voor het reinigen van vervuilde soldeernaalden.
Ruimers-Ø: 0,05; 0,08; 0,10; 0,15; 0,20; 0,25; 0,30; 0,35; 0,40; 0,45; 0,50 en 0,55 mm

2840 20  12 = 1 set



Spanningsmeter

Kwaliteit „Made in Germany“. Gebruikscomfort en functionele betrouwbaarheid zijn hier de opvallende eigenschappen. Het vinden van spanningsvelden bij glazen wordt door de inclinatie van het polarisatiefilter eenvoudig en gemakkelijk. Een groot testoppervlak en ergonomische kwaliteiten maakt het een optimale hulp in de werkplaats en verkooppriimte.

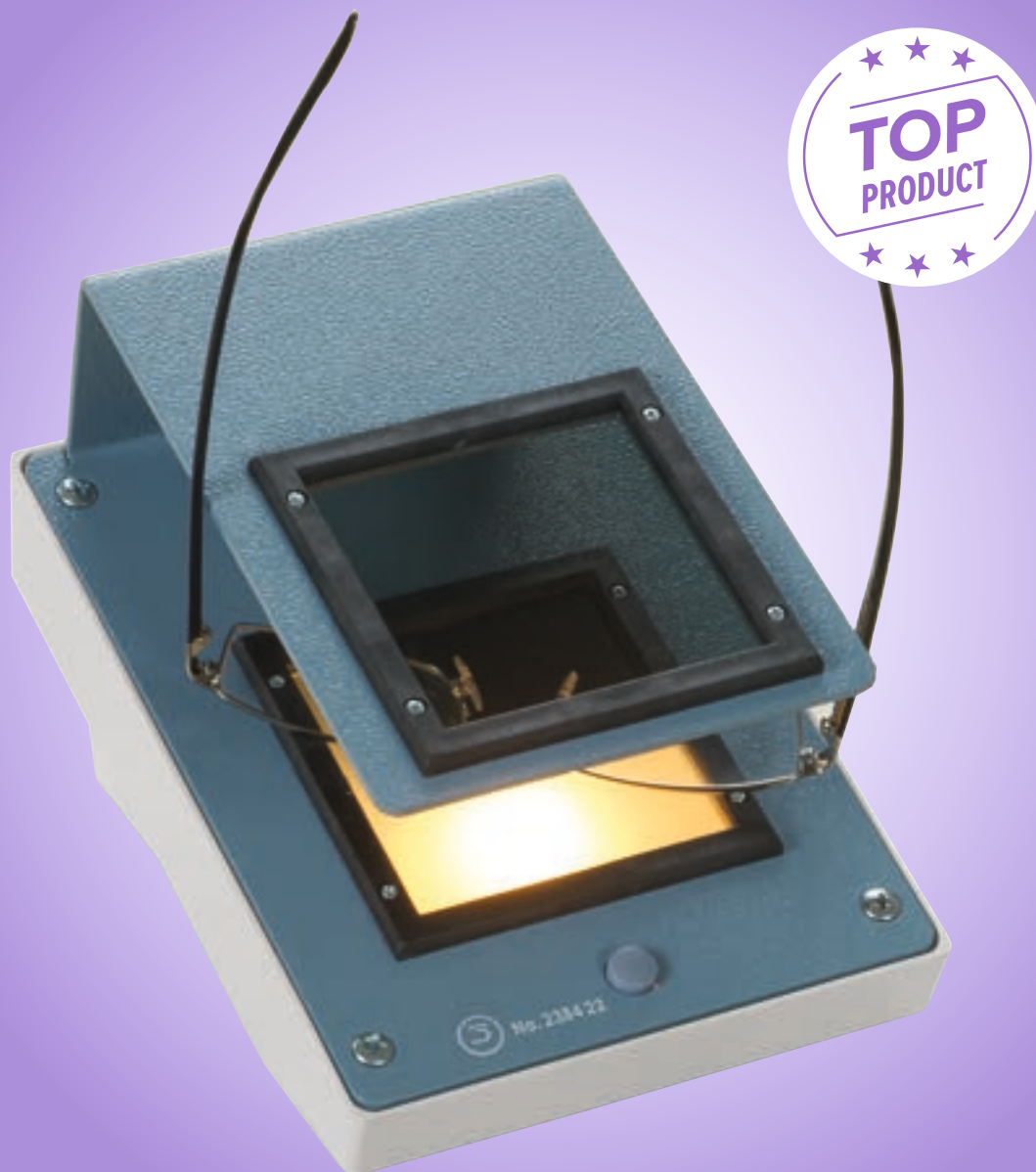

Spanningsmeter

- Vanaf nu met LED lichtvoorziening
- Met verlichting door drukknop
- Schakelt automatisch uit na ca. 15 s

2384 22

LED lichtvoorziening

Geschikt voor Nr. 2384 22.

2384 56

Technische specificaties

Afmetingen vensters:	68 x 68 mm
Afstand polariserende vensters:	50 mm
Tijdschakelaar:	ca. 15 s verlicht
Vermogen:	1,3 W
Verbruik per 10 min:	0,0002 kWh
Voltage:	230 V
Afmetingen (B x H x D):	130 x 130 x 175 mm
Gewicht:	700 g

36 maanden garantie!

Onderdelen verkrijgbaar bij uw leverancier.



GFC Spanningsmeter met regelbare inclinatie

- Comfortabele bediening door regelbare inclinatie van de vensters
- Geschikt voor brillen met hoge glascurve
- Extra brede afstand tussen de vensters
- Met interne verlichting

2397 22

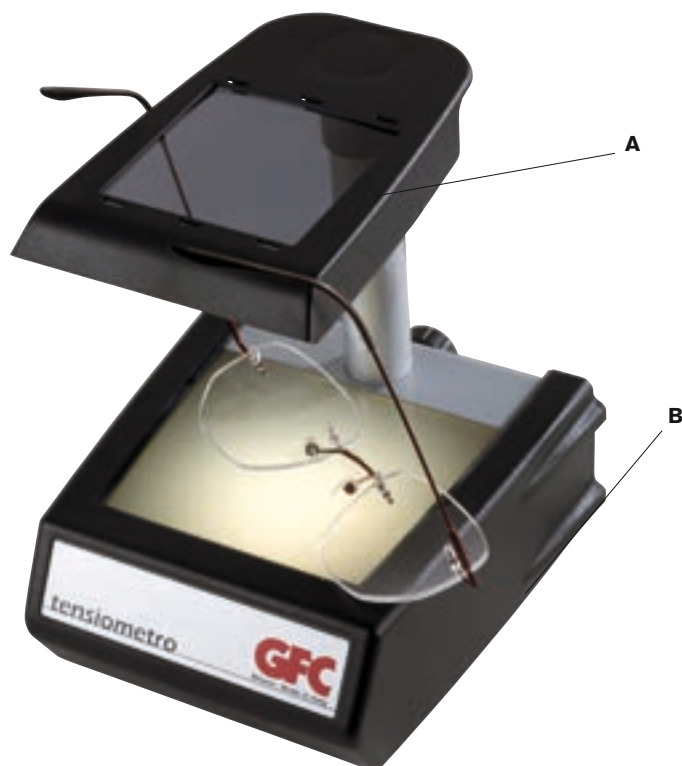

Technische specificaties

Afmetingen vensters:	A) 58 x 58 mm B) 75 x 75 mm
Afstand polariserende vensters:	95 mm
Vermogen:	6 W
Verbruik per 10 min:	0,0009 kWh
Voltage:	230 V
Afmetingen (B x H x D):	135 x 165 x 150 mm
Gewicht:	700 g

 **36 maanden garantie!**

 **Onderdelen** verkrijgbaar bij uw leverancier.



Hand-spanningsmeter

Met energiezuinige LED verlichting, incl. batterij, gemaakt van kunststof en metaal.

2393 20



Technische specificaties

Afmetingen vensters:	40 x 40 mm
Afstand polariserende vensters:	25 mm
Stroomvoorziening:	9 V blok (type PP3)
Afmetingen (B x H x D):	100 x 55 x 48 mm
Gewicht:	180 g

 **36 maanden garantie!**

 **Onderdelen** verkrijgbaar bij uw leverancier.

GFC UV-Test lamp

Testapparaat voor demonstratie van één-kleurige fototrope glazen aan de klanten.

2399 00



Technische specificaties	
Zekering:	0,5 A
Vermogen:	9 W
Verbruik per 10 min:	0,0014 kWh
Voltage:	230 V
Afmetingen (B x H x D):	220 x 125 x 120 mm
Gewicht:	1,75 kg

36 maanden garantie!

Onderdelen verkrijgbaar bij uw leverancier.

Transmissie meetapparaat

Onderzoekt de transmissie van brillenglazen in het zichtbare UV- en IR lichtbereik. Snelle en eenvoudige meting.

2412 00



Technische specificaties	
Meetbereik UV:	365 nm
Meetbereik VIS:	380–760 nm
Meetbereik IR:	950 nm
Meet tolerantie:	+/- 2%
Stroomvoorziening:	230V / 50Hz AC
Afmetingen (B x H x D):	200 x 106 x 180 mm
Gewicht:	1,5 kg

12 maanden garantie!

Onderdelen verkrijgbaar bij uw leverancier.

Q-Check testtoestel

Met de Q-Check is het mogelijk met precisie reeds gemonteerde en reeds gedragen brillen te testen.

Het compacte toestel combineert de volgende testen:

- Centreertest
- Graveerherkenning/markering van brilglazen
- Spanningstest
- Oppervlaktetest

2460 00



Technische specificaties	
Stroomvoorziening:	230 V/50 Hz
Afmetingen (B x H x D):	125 x 190 x 220 mm
Gewicht:	ca. 1,3 kg

24 maanden garantie!

Onderdelen verkrijgbaar bij uw leverancier.



Handig transmissie-meettoestel „Made in Germany”

Comfortabel in gebruik en gegarandeerd betrouwbaar bij het vaststellen van de meetgegevens. De OptiScan meet gelijktijdig UV- en lichttransmissie. De aanduiding gebeurt in procent. Onafhankelijk van netvoeding kan het apparaat overal in de verkooppriimte voor klantendemo's ingezet worden.



OptiScan transmissie meetapparaat

- Voor het meten van de transmissie van brillenglazen in het zichtbare en UV lichtbereik
- Testen van glazen apart en complete bril mogelijk
- Bijzonder geschikt voor de inzet tijdens het verkoopgesprek
- Klein, compact, batterij voeding

2411 00

Technische specificaties

Meetbereik:	VIS: 380–700 nm, UV: 320–380 nm
Stroomvoorziening:	9 V blok (type PP3)
Afmetingen (B x H x D):	110 x 130 x 120 mm
Gewicht:	860 g

24 maanden garantie!

Onderdelen verkrijgbaar bij uw leverancier.

GFC Gravure/markeringsvinder

- Voor het optimaal herkennen van aan de voor- en achterzijde aangebrachte gravures/markeringen op brillenglazen
- Comfortabele bediening door instelbare inclinatie van het testveld (75 x 75 mm)
- Geschikt voor brillen met hoge lenscurves

2451 00



Technische specificaties

Vermogen:	6 W
Voltage:	230 V
Afmetingen (B x H x D):	135 x 270 x 150 mm
Gewicht:	1,2 kg

36 maanden garantie!

Onderdelen verkrijgbaar bij uw leverancier.

UV lamp voor het uitharden van UV lijmen

- Voor activering van alle UV uithardende lijmen
- UV-bescherming voor de gebruiker
- Timer met 120 s en continu (bij Nr. 2431 00)
- De Nr. 2431 00 heeft een uitschuifbaar werkplateau
- Ruim verlicht veld
- Nr. 24211 00 met 15 energiezuinige LED lampen
- Nr. 24211 00 met 99 s timer en IR sensor

Technische specificaties	2431 00	2421 00
Vermogen:	36 W (4 x 9 W)	24 W
Verbruik per 10 min:	0,0059 kWh	0,0039 kWh
Voltage:	230 V	230 V
Afmetingen (B x H x D):	220 x 75 x 120 mm	215 x 75 x 120 mm
Gewicht:	900 g	200 g

2431 00

2421 00

 24 maanden garantie!

2431 00

3184 10



2421 00

3184 03

Buislamp voor UV lamp

Reservelamp voor Nr. 2430 00, 2420 00, 2430 20, 2420 10 en 2431 00.
Vermogen: 9 W

2431 01



LED lamp voor UV lamp

Reservelamp voor Nr. 2430 00, 2420 00, 2430 20, 2420 10 en 2431 00.
Vermogen: 9 W

2431 02



Onze UV gels vindt u op pagina E 11.



Glaskleurmachine Tinta met 2 pannen

- Apparaat voor het verwarmen van kleuringen voor ongecoate organische glazen
- Met temperatuurstelling en tijdschakelaar
- Ideaal voor het gebruik met B&S kleurpoeder Nr. 2615 01–2615 29
- Inclusief 2 RVS pannen en een RVS glashouder

Technische specificaties

Vermogen:	max. 1.035 W
Verbruik per 10 min:	0,1724 kWh
Vermogen:	230 V
Afmetingen (B x H x D):	160 x 220 x 430 mm
Gewicht:	4,2 kg

 **36 maanden garantie!**

 **Onderdelen** verkrijgbaar bij uw leverancier.

2880 01



Kleuren voor de glaskleurmachine vindt u op de pagina's E 20.

CLAVULUS, bewezen kwaliteit uit Duitsland

Sinds meer dan drie generaties eigenaren wordt de CLAVULUS door een fijnmechanisch bedrijf in het Zwarte Woud in Duitsland uitsluitend voor B & S gemaakt. Met deze klassieker laten zich ook heden ten dage nog vele klussen rondom de bril eenvoudig en betrouwbaar uitvoeren. Ambachtelijke precisie bij de vervaardiging en de tevreden gebruikers zorgen ervoor dat de CLAVULUS al bijna 75 jaar in het B & S assortiment zit. Een omvangrijk toebehoren vergroot de mogelijkheden. Opticiens bij wie het handwerk in het middelpunt staat, weten de kwaliteit te waarderen.



CLAVULUS

- Voor snelle en doelmatige reparaties
- **Speciale toebehoren:** Centerpons, doorslag, scharnierpons, enkele doorslag, dubbele doorslag en 7 aambeelden voor nieten

Het origineel met

 30 jaar garantie!

 Onderdelen verkrijgbaar bij uw leverancier.

2125 50

 135 x 290 x 175 mm

 2,5 kg



Toebehoren voor CLAVULUS

Neusbrugvormer

Met brede en smalle conus.

2125 26



Pons- en aambeeld- fixatieschroef

2147 00



Glasboortafel

- Door fixeerbare micrometer-schroef exacte afstand van glas rand naar boring
- Door 2 draaipunten exacte centrering naar de boor gegarandeerd
- Te gebruiken met verloopbus Nr. 2887 12 op de tafelboormachines Nr. 2887 20 en 2887 10 (uitverkocht) alsmede de boorstanders Nr. 2128 60 en 2128 70 (uitverkocht)



2129 00

- Incl. booropzet
Nr. 2129 01



Centerpons

2125 01



Doorslag

2125 02



Nietkoppons, Ø 1,5 mm 2125 04



Nietkoppons, Ø 2,1 mm

2125 05



Aambeeld met 1,8 mm boring

2125 41



Stempel

Voor het stempelen van monturen
(zie ook pagina B 31).

2125 31-39



Meer onderdelen
vindt u op pagina A 43.

CLAVULUS

- Voor snelle en doelmatige reparaties
- **Inclusief toebehoren:** o.a. ponsen, doorslagen, nietkoppons 1,5 en 2,1 mm, niettrekker, dubbele niettrekker, aambeeldverlenging en 9 aambeelden

2126 00

 165 x 210 x 265 mm

 3,3 kg

 **24 maanden garantie!**

 **Onderdelen** verkrijgbaar bij uw leverancier.



Toebehoren voor CLAVULUS

Geschikt voor Nr. 2126 00 en 2125 50.

Centerpons

2126 10



Nietkoppons, Ø 2,1 mm

2126 13



Pons voor scharnieren

2126 16



Doorslag

2126 11



Enkele doorslag

2126 14



Enkele doorslag

2126 17



Nietkoppons, Ø 1,5 mm

2126 12



Dubbele doorslag

2126 15



Dubbele doorslag

2126 18





Aambeeld met boor,
8 mm

2126 19



Aambeeld met gleuf

2126 20



Aambeeld voor nieten

2126 21



Aambeeld zonder boring

2126 22



Aambeeld met enkele boring

2126 23



Aambeeld met dubbele boring

2126 24



Aambeeldverlenging

2126 25



Wisser

2126 26



Aambeeld kunststof

2126 27



Aambeeld met gleuf

2126 28



Aambeeld met
1,8 mm boring

2126 29



Reservestiften

2126 30







TANGEN

elke greep past



- B 2 Paralleltangen
- B 4 Overzicht: eLite-, Standaard-tangen
- B 6 Inklinatie tangen
- B 8 Richt tangen
- B 10 Nylor tangen
- B 12 Tips & tricks: Curve tang
- B 16 Spits tangen
- B 19 Sluitbloktangen
- B 20 Padricht tangen
- B 22 Tips & tricks: Glasbril tangen
- B 25 Kopkniptangen
- B 30 Tips & tricks: Bionic Thumb
- B 33 Centertangen
- B 34 Glasversteltangen
- B 36 Deblocker tangen
- B 38 Stempeltang
- B 39 Zijknip- & kopkniptangen
- B 43 Tips & tricks: flexscharniertang
- B 45 Tangenstanders
- B 46 Tangengrepen

Paralleltangen – een innovatie van B & S

- **Parallele bekken**
Veilige grip door parallelle bekken in elke stand.
- **Lange grepen**
Voor optimale hefboomwerking met minimale krachtsinspanning en gering gewicht.
- **Kwaliteitsbekken „Made in Germany”**
Beproefde hoogste kwaliteit van de kunststof bekken voor bijzondere duurzaamheid.

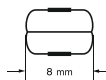

Richttang parallel 8 mm

Met twee kunststof bekken.
Zelfstandige opening door veermechanisme.

1551 00 P

—| 140 mm  135 g

Passende tangenbekken:

1551 01  1 paar



Inklinatietang parallel 8 mm

Eén kant met platte kunststof bek,
andere kant conisch gepolijst.
Zelfstandige opening door veermechanisme.

1558 00 P

—| 140 mm ●▲ 135 g

Passende tangenbek:

1558 01

Druktang parallel

Voor het in- en samendrukken van kunststofhulzen van glasbrillen
type Silhouette „Minimal Art” en gelijkende modellen.
Zelfstandige opening door veermechanisme.

1511 00 P

—| 140 mm ●▲ 140 g

Passende tangenbekken:

1511 01 ☐ 1 paar

B & S tangen* – tientallen jaren innovatie in je handen

- **Uniek design**

Ontwikkeld door B & S, wereldwijd beschermd.

- **10 jaar garantie**

(behalve kniptangen en de eLite flexscharnier tang 1514 .. en alle kunststof onderdelen)
Onverslijtbaar, solide, duurzaam.

- **Betrouwbare kwaliteit**

Gesmede uitvoering, nauwkeurig vervaardigd, duurzame kunststof bekken.



Onze Plasti Dip vindt u op pagina E 22 t/m E 23.



Onze praktische krimpkous voor tangengrepen vindt u op pagina B 46.





Standaard tangen – miljoenen keren beproefd

- **Robuuste uitvoering**
Ideaal voor iedereen die de wat zwaardere gereedschappen verkiest.
- **Lange grepen**
Voor optimale hefboomwerking met minimale krachtinspanning.
- **Gestructureerd oppervlak**
Geeft een goede grip, voorkomt wegglijden.

eLite tangen – het ultralichte alternatief

- **Handige uitvoering**
Ook geschikt voor kleinere handen.
- **Gering gewicht**
Lichte tangen voor minder inspanning.
- **Bijzonder vaste grip**
Asymmetrische en gestructureerde handvatten voor optimale grip, ze voorkomen wegglijden.

eLite: kleiner, lichter en met een matte afwerking



Inklinatie richttang – conisch 8 mm

Voor het richten van metaalbrillen.
Eén kant met kunststof bek en de andere kant met conische bek: Ø 6:1,5 mm.

Standard:

1558 00 N

150 mm 140 g

eLite:

1558 50

148 mm 100 g

Passende tangenbek:

1558 01



Inklinatie richttang – conisch 6 mm

Voor het richten van metaalbrillen. Voor **tere brilmonturen**.
Eén kant **met extra smalle kunststof bek** en de andere kant met conische bek: Ø 6:1,5 mm.

Standard:

1558 10 N

150 mm 140 g

eLite:

1558 55

148 mm 100 g

Passende tangenbek:

1558 02

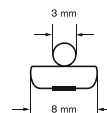

Inklinatie richttang – met inkeping 8 mm

Voor het buigen van dunne metalen monturen, één kunststof bek, conische bek: Ø 6,1,5 mm.

Standard:

1558 20 N

150 mm  140 g



Inklinatie richttang – cilindrisch 8 mm

Speciaal voor monturen met nylondraad, met bijzonder dunne metaalbek (cilindrisch), andere kant met kunststof bek.

Standard:

1596 00 N

150 mm  140 g

eLite:

1596 50

148 mm  100 g

Passende tangenbek:

1558 01

Passende tangenbek:

1596 01

Tangengreep – uw werkprofiel van B&S

- **Betere grip**
- **Comfortabeler werken**



Onze praktische krimpkouss voor tangengrepen vindt u op pagina B 46.

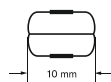

Richttang 10 mm

Met kunststof bekken,
parallel tot ca. 3 mm.

Standard:

1553 00 N

150 mm  140 g

Passende tangenbekken:

1553 01  1 paar



Richttang 8 mm

Met kunststof bekken.

Standard:

1551 00 N

150 mm  140 g

eLite:

1551 50

148 mm  100 g

Passende tangenbekken:

1551 01  1 paar



Richttang 6 mm

Met kunststof bekken,
parallel tot ca. 3 mm.

Standard:

1565 00 N

150 mm  140 g

eLite:

1565 50

148 mm  100 g

Passende tangenbekken:

1565 01  1 paar





Curvetang 24 mm

Met kunststof bekken, brede uitvoering.

Standard:

1507 00 N

150 mm  140 g

eLite:

1507 50

145 mm  110 g

Passende tangenbekken:

1507 01  1 paar



Curvetang 19 mm

Met kunststof bekken, smalle uitvoering.

Standard:

1509 00 N

145 mm  140 g

Passende tangenbekken:

1509 01  1 paar

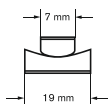

eLite



Curvetang 19/7

1 kunststof bek (19 mm), 1 kunststof bek (7 mm).
Bijzonder geschikt voor het buigen van bruggen.

Standard:

1506 00 N

145 mm  140 g

Passende tangenbekken:

1506 01  1 paar

Curvetang 15/12

1 kunststof bek (15 mm), 1 kunststof bek (12 mm).
Bijzonder geschikt voor het buigen van bruggen.

Standard:

1584 00 N

145 mm  140 g

eLite:

1584 50

137 mm  100 g

Passende tangenbekken:

1584 01  1 paar



TIPS & TRICKS

BUIGTANG MET 3 KUNSTSTOF ROLLEN

Eén tang voor verschillende toepassingen!

Buigtang met 3 kunststof rollen

Bestelnr. 1566 00 N, 1566 50



ca. 1-2 minuten

Zo werkt het

VOOR HET AANPASSEN VAN:

1 VEREN



2 MONTUURRAND



3 NEUSBRUG



4 OORTIPS



5 GLASMODEL





Buigtang met 3 kunststof rollen

Kan gebruikt worden bij het verstellen van: monturen, neusbruggen, veren en oortips.

Standard:

1566 00 N

150 mm  140 g

eLite:

1566 50

148 mm  95 g

Passende tangenbekken:

1566 01  1 set



eLite: kleiner, lichter en met een matte afwerking



Onze Plasti Dip vindt u op pagina E 22 t/m E 23.



Onze krimpkous vindt u op pagina F 75.

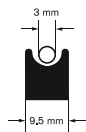

Buigtang

Afgeleid van het concept van de driepuntstang. Deze tang is bijzonder geschikt om materiaalbeschadiging te voorkomen. Aan de ene kant voorkomt de kunststof bek krassen, aan de andere kant de mogelijkheid om krimpkous of Plasti Dip te plaatsen.

Standard:

1544 00 N

| 140 mm  140 g

eLite:

1544 50

| 137 mm  90 g



Driepuntstang

Voor het nauwkeurig en eenvoudig aanpassen van voorhangerklemmen.

Standard:

1513 00 N

| 140 mm  140 g

eLite:

1513 50

| 137 mm  100 g

Passende tangenbek:

1544 01



Ronde spitstang

Binnenzijde bekken rond.

Standard:

1501 00 N

150 mm  140 g

eLite:

1501 50

148 mm  100 g



Ronde spitstang met gebogen bekken

Binnenzijde bekken rond en inkepingen in de punt.

Standard:

1501 10 N

150 mm  140 g



Spitstang vlak – extra lang

Binnenzijde bekken vlak.
Extra lang en dunne uitvoering.

Standard:

1564 00 N

155 mm 140 g

eLite:

1564 50

148 mm 100 g



Spitstang vlak

Binnenzijde bekken vlak.

Standard:

1515 00 N

150 mm 140 g

eLite:

1515 50

148 mm 100 g



Spitstang vlak, half rond

De ene binnenzijde rond, de andere vlak.

Standard:

1517 00 N

150 mm 140 g



Vlaktang 5 mm

5 mm brede bek.

Standard:

1523 00 N

150 mm 140 g



Vlaktang 3 mm

3 mm brede bek.

Standard:

1522 00 N

150 mm 140 g

eLite:

1522 50

148 mm 95 g



Paddruktang

Voor het verwijderen van klikpads.

Standard:

1502 00 N

150 mm 140 g

eLite:

1502 50

148 mm 100 g



Sluitbloktang

Voor het dichttrekken van de montuurrand bij de sluitblokken.

Standard:

1542 00 N

—| 145 mm  140 g

eLite:

1542 50

—| 139 mm  95 g



Sluitbloktang – groot

Voor het dichttrekken van de montuurrand bij de sluitblokken, met extra lange armen.

Standard:

1531 00 N

—| 155 mm  140 g

eLite:

1531 50

—| 145 mm  90 g

Tangengreep –

uw werkprofiel van B&S

- **Betere grip**
- **Comfortabeler werken**



Onze praktische krimpkouss voor tangengrepen vindt u op pagina B 46.

**Padrichttang – universeel**

Optimaal voor het aanpassen van klik-, schroef of Primadonna pads.

Standard:**1550 10 N**

| 150 mm

155 g

eLite:**1550 55**

| 148 mm

120 g



Padrichttang – klikpads

Optimaal voor het aanpassen van klikpads. Fijne uitvoering voor het vermijden van glascontact bij het aanpassen.

Standard:

1549 00 N

150 mm  140 g

eLite:

1549 50

147 mm  95 g



Padrichttang – schroefpads

Voor schroefpads. Verbeterde, fijne uitvoering voor het vermijden van glascontact bij het aanpassen.

Standard:

1546 00 N

150 mm  140 g

eLite:

1546 50

148 mm  95 g



TIPS & TRICKS

IN- EN UITDRUKKEN VAN KUNSTSTOFHULZEN

Hulzen in- en uitdrukken eenvoudig!

Druktang met hefboomfunctie

Bestelnr. 1567 00 N, 1567 50

Uitdruktang

Bestelnr. 1568 00 N, 1568 50

Verglazingshulp

Bestelnr. 2269 10

Speciale kopkniptang voor kunststofhulzen

Bestelnr. 1569 50



ca. 5 minuten

Zo werkt het



INDRUKKEN:

1 INZETTEN



2 AFKNIPPEN



3 MONTEREN



UITDRUKKEN:

4 INDRUKKEN



1 AFKNIPPEN



2 UITDRUKKEN



BEKKENWISSEL:

1 VERWIJDEREN



2 DRAAIEN



3 VASTZETTEN





Druktang met hefboomfunctie voor glasbrillen

Met verticale en horizontale groef in de ene bek en daar tegenover een flexibele bek om gelijkmatig druk uit te oefenen op het glas. Voor het in- en samendrukken van kunststofhulzen van glasbrillen zoals „Minimal Art“ en gelijkende modellen.

Standard:

1567 00 N

150 mm  140 g

eLite:

1567 50

148 mm  95 g

Passende tangenbekken:

1567 01  1 paar



Druktang met wendbare bekken voor glasbrillen

Voor het uitdrukken van kunststofhulzen. Door de horizontaal en verticaal geplaatste pinnen kan de tang in twee richtingen gebruikt worden.

Standard:

1568 00 N

150 mm  140 g

eLite:

1568 50

148 mm  95 g

Passende tangenbekken:

1568 01  1 paar



Druktang

Voor het in- en samendrukken van kunststofhulzen van glasbrillen type Silhouette „Minimal Art” en gelijkende modellen. Met verticale en horizontale groef.

Standard:

1511 00 N

150 mm  145 g

eLite:

1511 50

145 mm  100 g

Passende tangenbekken:

1511 01  1 paar



Druktang met O-ringen

Voor het in- en samendrukken van kunststofhulzen van glasbrillen type Silhouette „Minimal Art” en gelijkende modellen. Met horizontale gleuf. Vergelijkbaar met Nr. 1511 00 N, is echter voorzien van diepere groeven en verwisselbare O-ring. Bij de levering zijn 5 rubberen O-ringen inbegrepen.

Standard:

1511 10 N

150 mm  145 g

Passende tangenbekken:

1511 02  1 paar

Reserve O ring:

1511 03  5 stuks

Sinds jaren onze bestseller en niet zonder reden.

Met de rubberen, ergonomische handgrepen en geïntegreerde veer voor een automatische opening van de tang biedt de speciale kopniptang een hoog comfort bij professioneel gebruik in de werkplaats. Het fijne knippen vermindert het bekrassen van glazen en maakt gladde snijvlakken, zelfs bij zachte kunststofhulzen. Door het verbeterde materiaal aan de snijvlakken en het uitsluitend gebruik van kunststoffen is een lange levensduur gegarandeerd.



Tangen



Speciale kopniptang voor kunststofhulzen

Voor het afknippen van kunststofhulzen van monturen type Silhouette „Minimal Art“. Door de slanke vorm van de bekken en de fijne snijvlakken wordt het gevaar van krassen vermindert.

Niet geschikt voor metaal.

Standard:

1569 00 N

140 mm  140 g

eLite:

1569 50

137 mm  95 g

Met kunststof handgreep en springveer:

1569 11

115 mm  70 g



Speciale zijknijptang voor kunststof

Voor het knippen van nylordraad bij, of in het boorgat. Door de slanke vorm van de bekken en de fijne snijvlakken wordt het gevaar voor bekrassen van glazen verminderd. **Niet geschikt voor metaal.**

eLite:

1583 50

|—| 100 mm ●▲ 40 g



Speciale tang voor schroefloze glasbrillen

Tang met 2 sleuven voor het eenvoudig demonteren van schroefloze monturen type Silhouette „Minimal Art” of gelijkende modellen.

Standard:

1518 00 N

|—| 140 mm ●▲ 140 g

eLite:

1518 50

|—| 137 mm ●▲ 95 g

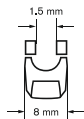

Onze praktische krimpkous voor tangengrepen vindt u op pagina B 46.



Richttang voor glasbrillen

Speciaal voor het uitrichten van glasbrillen.
Stevige grip op schroeven en moeren.

Standard:

1539 00 N

155 mm  140 g

Passende tangenbek:

1539 01



Schroevenkniptang

Voor het inkorten van glasbrilschroeven van nieuwzilver en messing.
Niet geschikt voor stalen schroeven.

Standard:

1578 00 N

130 mm  125 g



Scharnierrichttang

Met kleine uitsparingen in de bekkenpunten, parallel tot ca. 1 mm.
Bekbreedte: 4,0 mm

Standard:

1548 00 N

—| 148 mm  140 g

eLite:

1548 50

—| 137 mm  90 g



Scharnieroogrichttang

Voor het eenvoudig buigen en richten van scharnierogen.

Standard:

1555 00 N

—| 145 mm  140 g



Scharnierrichttang

Bekbreedte: 1,5 mm

Standard:

1538 00 N

—| 148 mm ●▲ 140 g



Windsorringtang

Voor het inkerven en knippen van windsorringen.

Standard:

1580 00 N

—| 150 mm ●▲ 150 g



TIPS & TRICKS

BIONIC THUMB

Duimkracht geweest

Bionic Thumb

Bestelnr. 20 450 0000, 1000

Professionele schroevendraaier

Bestelnr. 1664 ..



ca. 1 minuut

Zo werkt het

VOOR HET AANPASSEN VAN:

1 VEREN



2 OORTIPS



3 VOORSTUK



ALS BASIS VOOR:

4 NEUSSTEUN



1 SCHROEVEN









Bionic Thumb origineel

- Voor het buigen van verschillende montuurdelen
- Super handig en gebruiksvriendelijk
- Van geborsteld edelstaal met duurzame wildlederen buigoppervlakken

20 450 0000  1 stuk

 135 x 15 x 22 mm  90 g

20 450 1000  2 stuks

 135 x 15 x 22 mm  90 g

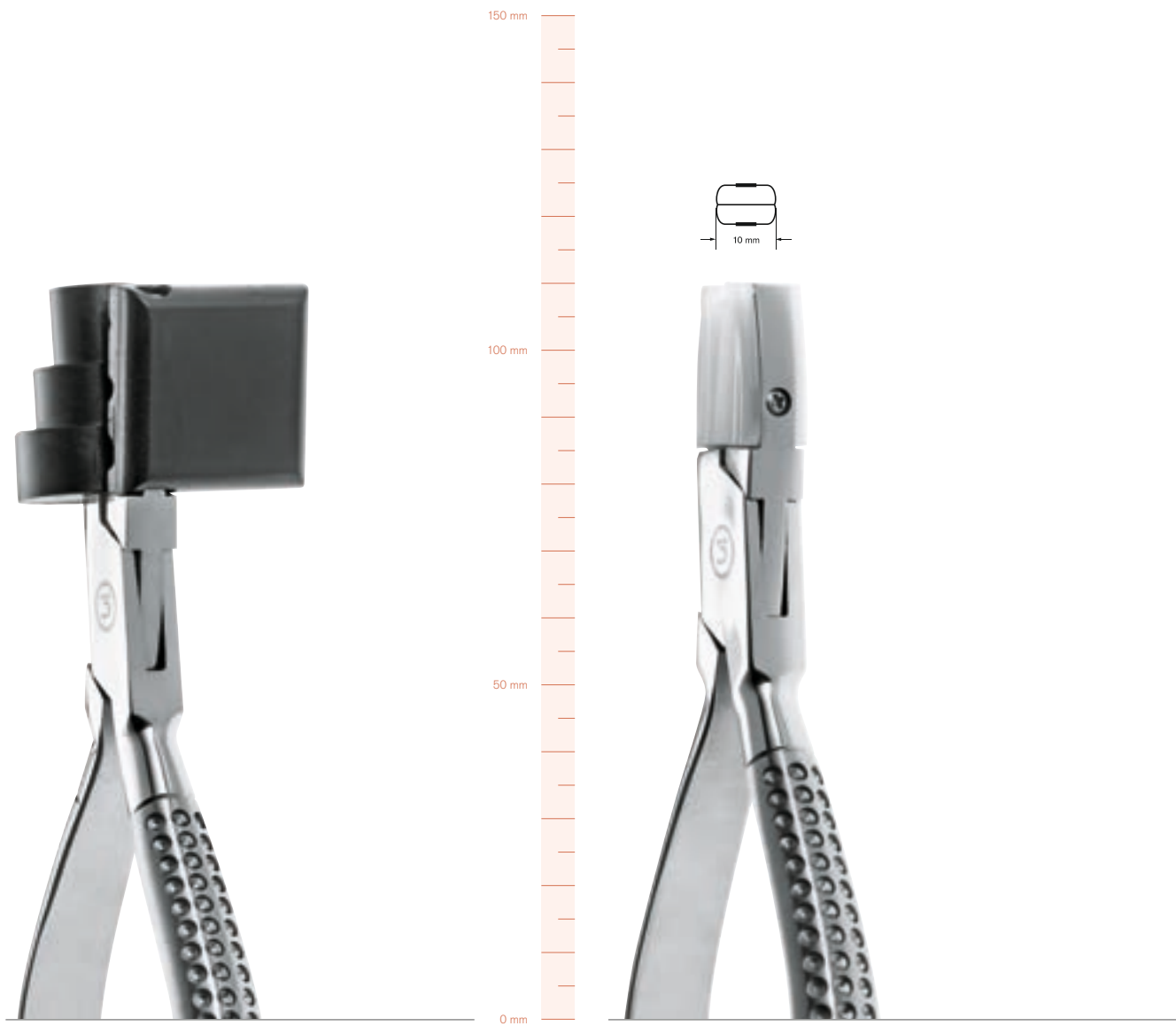

Brilveer buigtang

1 platte kunststof bek met 3 verschillende groeven en een ronde kunststof bek met 3 verschillende diameters. Speciaal voor het aanpassen van alle veersoorten. Door de gelijkmatige vervorming en de constante druk op het werkstuk, is een bijzonder materiaalsparende bewerking gewaarborgd.

Standard:

1541 00 N

—| 150 mm ●▲ 140 g

Passende tangenbekken:

1541 01 📦 1 paar



Brilveer buig en curvetang

Met twee speciale kunststof bekken, die aan een kant convex en aan de andere kant concaaf gebogen zijn, loodrecht op de buigingen is in beide kunststof bekken een dwarsleuf gefreesd.

Standard:

1530 00 N

—| 150 mm ●▲ 140 g

Passende tangenbekken:

1530 01 📦 1 paar



Centertang

Met schroefbare centerpunt en puntvormig verdiept aambeeld ter vermindering van het drukken tegen het montuur.

Standard:

1527 10 N

150 mm  140 g

eLite:

1527 50

140 mm  95 g

Reservecenterpunten:

1537 02  3 stuks

Centertang – gehoekt

Gehoekte bekken voor een betere hantering bij moeilijk bereikbare plekken. Met schroefbare centerpunt en puntvormig verdiept aambeeld ter vermindering van het drukken tegen het montuur. Parallelstelling van de bekken bij ca. 3 mm.

Standard:

1527 20 N

145 mm  150 g

eLite:

1527 55

140 mm  110 g

Reservecenterpunten:

1537 02  3 stuks





Glasversteltang 32 mm

Met verlengde bekken, parallelle bekkenpunten, gestante rubber-schijven voor vaste grip op het glas. Vaste schijf: Ø 32 mm (gestanst Ø 15 mm), beweegbare, verende schijf: Ø 26 mm. Benutbare ruimte van de bekken: 40 mm.

Standard:

1516 01 N

|—| 200 mm ●▲ 240 g

Reserve rubberschijven:

1532 01 ☐ 1 paar

Reserveschijven compleet met veer:

1534 02



Glasversteltang 20 mm

Als Nr. 1516 01 N, maar met twee gelijk grote rubberschijven van Ø 20 mm – speciaal voor kleine monturen. Veermechanisme in de greep. Ongestant.

Standard:

1516 20 N

|—| 200 mm ●▲ 240 g

Reserve rubberschijven:

1535 20 ☐ 1 paar



Brokkeltang

Met verwisselbare bekken, inclusief verwisselbare bekken.

Standard:

1561 00 N

—| 145 mm  140 g

Passende reservebakken:

1561 02  1 paar



Tangengreep – uw werkprofijs van B&S

- **Betere grip**
- **Comfortabeler werken**



Onze praktische krimpkouss voor tangengrepen vindt u op pagina B 46.



Deblockertang

Voor het verwijderen van afnameblokken van kunststof of siliconen, verticaal gebruik.

Standard:

1520 00 N

—| 148 mm

•▲ 140 g





Deblockertang voor NIDEK

Speciale tang voor het deblocken van NIDEK afnameblokken.
Passend voor de NIDEK Mini cup en de P-cup.

Standard:

1592 00 N

 148 mm  140 g

Deblockertang voor NIDEK

Speciale tang voor het deblocken van NIDEK afnameblokken.
Passend voor de NIDEK Mini cup en de P-cup.

eLite:

1591 50

 145 mm  125 g

Passende reservebakken:

1591 01  1 paar

Merk al uw brilmonturen met het kenmerk van uw winkel.

Wij maken de stempelleg volgens schrijffvoorbeeld, die u met de opdracht meestuurt. Als u geen schrijffhoogtevoorbeeld heeft, maken wij de schrijffhoogte 1,5 mm. Omkaderde tekens worden in verhouding aangepast. De schrijffhoogte van 1,5 mm wordt niet veranderd. Maximale schrijffhoogte is 2,0 mm. Meer dan 9 letters en/of tekens is niet wenselijk, omdat een gave afdruk niet gegarandeerd wordt.



Berekening van een stempel

Bij een van onderstaande bestelnummers vindt u telkens de prijs voor het aantal tekens. Als u bijvoorbeeld de stempelleg **BRO** voor de CLAVULUS besteld, vindt u de prijs bij Nr. 2125 33. **Speciale tekens en/of gravures** als bijv. een montuur, een monocle, een logo of afwijkende schrijfwijze en versieringen die anders zijn dan bovengenoemd voorbeeld, worden naar moeilijkheidsgraad **5- tot 8x van de enkelprijs** berekend.

Rekenvoorbeelden voor stempelleg met 1,5 mm schrijffhoogte:

Tekenvoorbeeld:

K5	berekend als:	2 tekens
B R O		3 tekens
MEIER		5 tekens

Speciale tekens, bijv.

△, △, ○, □, 7, ∞



Stempeltang

Voor het merken van brilmonturen.
De inleg wordt naar uw wens gemaakt.

Standard:

1590 00

165 mm  280 g



Stempel voor stempeltang Nr. 1590 00

1590 31 1 teken

1590 32 2 tekens

1590 33 3 tekens

1590 34 4 tekens



Stempel voor CLAVULUS niet- apparaat Nr. 2125 00, 2125 50

(zie pagina A 46) en 2126 00 (zie pagina A 42)

2125 31 1 teken

2125 32 2 tekens

2125 33 3 tekens





Zijkniptang

Met dubbel scharnier en hardmetalen snijvlak, speciaal voor hard draad en stalen schroeven **tot 1,4 mm** diameter geschikt.

Standard:

1579 00 N

 180 mm  240 g





Kopkniptang

Met facet, dubbel scharnier en hardmetalen snijvlak, speciaal voor hard draad en stalen schroeven **tot 1,4 mm** diameter geschikt.

Standard:

1579 79 N

 170 mm  240 g



Kopkniptang

Met hardmetalen snijvlak,
voor stalen schroeven **tot max. 1,4 mm.**

Standard:

1577 10 N

—| 145 mm  140 g



Zijkniptang

Met ingezette hardmetalen snijvlakken
voor edelstaal draad **tot max. 2,0 mm.**

Met kunststof handgreep:

1581 00

—| 175 mm  200 g



Zijkniptang

Met hardmetalen snijvlak,
voor stalen schroeven **tot max. 1,4 mm.**

Standard:

1570 00 N

140 mm  140 g



Als u met de zijkniptangen materialen knipt die in diameter groter zijn dan voorgeschreven, bijv. als u gehard staal knipt, kan het tot breuk of beschadiging van de kniptang leiden. De snijvlakken moeten zo mogelijk niet aan de voor en buitenkanten, maar meer in het midden gebruikt worden.



Zijkniptang

Voor stalen schroeven **tot max. 1,6 mm,**
met kunststof handgreep.

Met kunststof handgreep:

1574 00

140 mm  145 g



Zijkniptang

Grotere versie van zijkniptang Nr. 1576 05.
Voor titanium en stalen schroeven **tot 1,4 mm.**

Met kunststof handgreep:

1576 15

|—| 130 mm  100 g



Zijkniptang

Extreem fijne en spitse snij-oppervlakken,
voor titanium en stalen schroeven **tot max. 1,2 mm.**

Met kunststof handgreep:

1576 05

|—| 115 mm  75 g



TIPS & TRICKS

EENVOUDIGE MONTAGE VAN VEREN MET EEN FLEXSCHARNIER

*Montage van flexscharnieren, zo klaar!***Flexscharnietangset**

Bestelnr. 1514 99

of afzonderlijk:

Flexscharnietang

Bestelnr. 1514 55

Spanner

Bestelnr. 1514 56

Schroevendraaierspindel

Bestelnr. 1627 00

Reserve onderdeel

Bestelnr. 1514 58



Tangen



ca. 1 minuut

*Zo werkt het***Optie 1:** Montage met tang, pincet en spanner**1 BEVESTIGEN****2 AANDRUKKEN****3 VASTHOUDEN****4 KLEMMEN****5 LOSMAKEN VAN DE VEER****6 AANTREKKEN EN TANG VERWIJDEREN****Optie 2:** Montage met stiften, pincet en spanner | **Herhaal de stappen 1-3****4 KLEMMEN****5 LOSMAKEN VAN DE VEER****6 AANTREKKEN EN STIFT VERWIJDEREN**

Set flexscharniertang

De tang grijpt alleen de hals van het scharnieroog en niet meer aan de buitenkant van de veer. Geen krassen op de veer!

De boring van het oog wordt aangespannen en met behulp van de tang of de stift vastgehouden het inschroeven van het scharnier wordt zo vereenvoudigd.

Bij levering inclusief de handige spanner Nr. 1514 56, de stift Nr. 1514 58 en de pincet Nr. 1627 00.



„Eenvoudige montage van veren met een flexscharnier“ (zie pagina B 43)

1514 99



Flexscharniertang met stiften en gereedschap

1514 55

Schroevendraaierpincet

1627 00

Reserve gereedschap:

1514 56

Reserve stiften:

1514 58

3 stuks



Tangenstander

„Made in Germany“, massief beukenhout met metalen inleg voor ca. 10 tangen, en legbord met metalen beschermlijst.



Design
Award
Winner
2000

Past bij

1664 50 Schroevendraaierset in houten blok

Met 4 schroevendraaiers, stiften 1,0; 1,4; 1,8 en 2,3 mm, alsmede 1 schroevendraaier, kruiskop maat 2,0 mm

De afgebeelde tangen zijn niet bij de levering inbegrepen!

1460 40

200 x 130 x 105 mm

960 g



Tangen



Tangenstander

Kleur: Transparant

Acrylglas. Met 6 boringen van elk Ø 10 mm en Ø 12 mm, voor het opbergen van schroevendraaiers e.d

De afgebeelde tangen zijn niet bij de levering inbegrepen!

1460 17

300 x 130 x 165 mm

700 g



Praktische krimpkous voor tangengrepen

Individueel te knippen voor elke greep. De krimpkous is een weinig gestructureerd voor een betere grip. Beide einden zijn open. Zit na krimpung vast op de greep.

Ø 15 mm

1468 0 .  4 paar (elk 8 cm)

1468 00 Zwart **1468 02** Rood

1468 01 Blauw **1468 03** Groen

1468 1 .  1 m

1468 11 Blauw

Assortiment met alle kleuren

1468 50  16 paar (elk 4 paar per kleur)





Tangenstander

RVS, voor ca. 10 tangen. Nu met antislip rubberen ringen. Geen krassen meer aan oppervlakken.

De afgebeelde tangen zijn niet bij de levering inbegrepen!

1461 10

 180 x 100 x 110 mm  450 g

Passende rubberen ringen
Kleur: Zwart

1461 11  4 stuks



Tangenstander



Van helder acrylglas, voor het opbergen van 10 resp. 5 tangen.

De tangenstander wordt gedemonteerd geleverd. Eenvoudige montage.



De afgebeelde tangen zijn niet bij de levering inbegrepen!

Nieuwe maat:

1460 18 Voor ca. 5 tangen

 120 x 125 x 120 mm  200 g

1460 19 Voor ca. 10 tangen

 238 x 112 x 125 mm  400 g

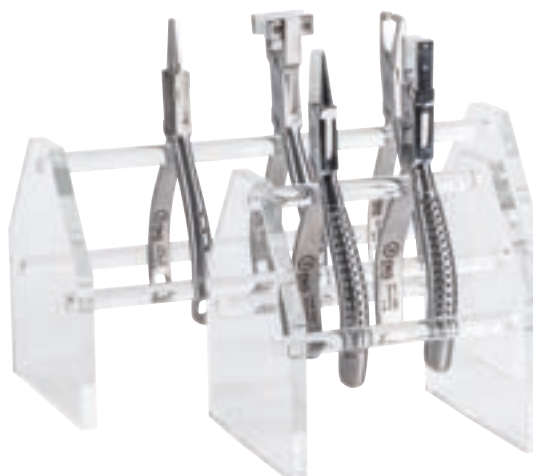

Magneetstrip ECO

De afgebeelde tangen en gereedschappen zijn niet bij de levering inbegrepen!

1411 05

 500 x 140 x 23 mm

 375 g

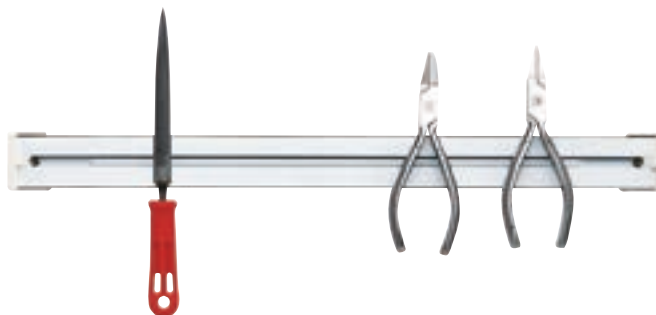

B&S gereedschap- en onderdelenetui

Handig gereedschapsetui voor onderweg. Met de meest gebruikte gereedschappen en onderdelen om buiten de werkplaats brillen te justeren en/of te repareren.

Inclusief de volgende gereedschappen:
1x 1558 55, 1x 1551 50, 1x 1549 50,
1x 1548 50, 1x 1651 00, 1x 1626 00,
1x 1683 90, 1x 2373 00, 1x 1639 00,
1 onderdelenbox met pads en schroeven

1464 00

 270 x 150 x 50 mm

 730 g



Gereedschaptas klein voor broekriem

Praktische gereedschaptas voor bevestiging aan een broekriem. Voor tangen, stiften, pd meter etc.

1467 00

 190 x 210 x 190 mm

 430 g







PRECISIEGEREED- SCHAPPEN

voor gecompliceerde opdrachten



- C 2 Schroevendraaiers & moersleutels
- C 14 Derde hand
- C 15 Aambeeldtoren
- C 16 Pincetten
- C 18 Knippen en snijden
- C 21 Ruimers
- C 22 Tappen
- C 24 Tips & tricks: Glasbeschermer Henry
- C 26 Tips & tricks: Nylorinlegdraad instrument
- C 27 Montagehulp voor glasbrillen
- C 28 Tips & tricks: Schroevenkorter
- C 31 Kleine gereedschappen
- C 32 Boren en frezen
- C 37 Gereedschaphouders
- C 38 Vijlen
- C 42 Bankschroeven
- C 43 Zagen



B & S Opticiensschroevendraaiers „Made in Germany”

Duurzaamheid, precisie en perfecte werking.

De stiften van de schroevendraaiers vervormen of breken niet: ze zijn vervaardigd uit gehard, veredeld gereedschapsstaal voor de ideale combinatie van hardheid en flexibiliteit.

Snelle verwisseling van de stiften: perfecte pasnauwkeurigheid van de stiften in de handgrepen, met een eenvoudige klemming. Geen drukplaatsen in de hand, ergonomisch design, in de praktijk bewezen hoogste functionaliteit.

U mag niet met minder tevreden zijn.



Opticiensschroevendraaier in B & S Design

- Opnameschacht voor kruis- en gleufstiften en moersleutels
- Met verlengde grip en grotere knop voor comfortabel werken
- Geleerde draaiknop, de ovale vorm voorkomt het weggrollen van de schroevendraaier op het werkblad
- Schachtmaat: 2,5 mm, klemstift

1664 .. | 115 mm



1664 01	1664 00	1664 10	1664 14	1664 18	1664 23
Groen	Groen	Grijs	Blauw	Rood	Zwart

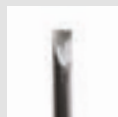
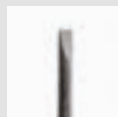
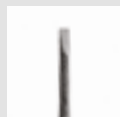
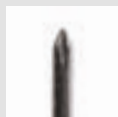
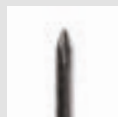
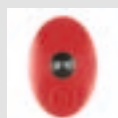
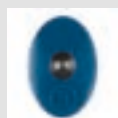

Bladbreedte:
+ 1,5 mm

Bladbreedte:
+ 2,0 mm

Bladbreedte:
- 1,0 mm

Bladbreedte:
- 1,4 mm

Bladbreedte:
- 1,8 mm

Bladbreedte:
- 2,3 mm

Reservestift:
1711 26

Reservestift:
1711 25

Reservestift:
1711 10

Reservestift:
1711 14

Reservestift:
1711 18

Reservestift:
1711 23



Reservestiften: Schachtmaat 2,5 mm, klemstift

3 stuks

Schroevendraaierset

- In halfronde houten staander
- Met 5 schroevendraaiers van de serie B & S opticiensschroevendraaiers 1664 ..
- 4 gleufkopstiften 1,0; 1,4; 1,8; 2,3 mm, 1 kruiskop 2 mm

1664 50



Design
Award
Winner
2000



Hulzenset

- 5 inzetbare hulzen met groot opschrift
- Voor het achteraf monteren in werkbladen of verkoopruimte

1465 50



OptiCar – inclusief schroevendraaiers

- Hoge kwaliteit metalen design met solide rubberen wielen
- Met 5 schroevendraaiers van de B&S opticiensschroevendraaiers 1664 ..
- 4 gleufkopstiften 1,0; 1,4; 1,8; 2,3 mm
- 1 kruiskop 2,0 mm

1664 60



Draaistander

- Draaibare aluminiumstaander
- Met 6 schroevendraaiers van de B&S opticiensschroevendraaiers 1664 ..
- 4 gleufkopstiften 1,0; 1,4; 1,8; 2,3 mm
- 2 kruiskopstiften 1,5 en 2,0 mm

1664 61



Kunststofstander

- Met 6 schroevendraaiers van de B&S opticiensschroevendraaiers 1664 ..
- 4 gleufkopstiften 1,0; 1,4; 1,8; 2,3 mm
- 2 kruiskopstiften 1,5 en 2,0 mm

1664 62



B & S Opticiensmoersleutel „Made in Germany”

Duurzaamheid, precisie en perfecte werking.

De stiften van de moersleutels vervormen of breken niet: ze zijn vervaardigd uit gehard, veredeld gereedschapsstaal voor de ideale combinatie van hardheid en flexibiliteit.

Snelle verwisseling van de stiften: perfecte pasnauwkeurigheid van de stiften in de handgrepen, met een eenvoudige klemming. Geen drukplaatsen in de hand, ergonomisch design, in de praktijk bewezen hoogste functionaliteit.

U mag niet met minder tevreden zijn.

Opticiensmoersleutel in B & S Design

- Opnameschacht voor kruis- en gleufstiften en moersleutels
- Met verlengde grip en grotere knop voor comfortabel werken
- Geleerde, ovale draaiknop voorkomt het weggrollen van de schroevendraaier op het werkblad
- Schachtmaat: 2,5 mm, klemstift



1664 . . | 115 mm



1664 40
⊗ 2,2 mm



Ster, 6 punts

Reservestift:
1711 40

1664 42
⊙ 2,6 mm



Zeskant, voor
grote moeren

Reservestift:
1711 42

1664 43
⊗ 2,6 mm



Ster, 6 punts,
voor grote
stermoeren

Reservestift:
1711 43

1664 44
⊙ 2,2 mm

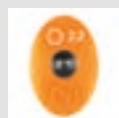

Zeskant, voor
kleine moeren

Reservestift:
1711 44

1664 45
⊗ 2,0 mm

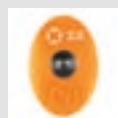

Ster, 4 punts

Reservestift:
1711 45

1664 46
⊗ 2,1 mm



Ster, 6 punts,
voor de meest
gangbare
moeren

Reservestift:
1711 46

1664 48
⊙ 2,0 mm



Ster inbus,
6 punts, voor
grote moeren

Reservestift:
1711 48

1664 49
⊙ 2,3 mm



Zeskant, voor
dopmoeren

Reservestift:
1711 49



Reservestiften: Schachtmaat 2,5 mm, klemstift

3 stuks

OptiCar – inclusief moersleutels

- Hoge kwaliteit metalen design met solide rubberen wielen
- Met 5 moersleutels van de B & S serie 1664 ..
- 2 zeskant 2,3; 2,6 mm
- 3 ster 2,1; 2,2; 2,6 mm

1664 70



Draaistander

- Draaibare aluminiumstaander
- Met 8 moersleutels van de B & S serie 1664 ..
- 4 zeskant 2,0; 2,2; 2,3; 2,6 mm
- 4 ster 2,0; 2,1; 2,2; 2,6 mm

1664 71



Kunststofstander

- Met 8 moersleutels van de B & S serie 1664 ..
- 4 zeskant 2,0; 2,2; 2,3; 2,6 mm
- 4 ster 2,0; 2,1; 2,2; 2,6 mm

1664 72



















B & S Standaardserie schroevendraaiers

- Opnameschacht voor kruis- en gleufstiften en moersleutels
- Gegroefde handgreep voor optimale grip
- Geleerde, **ronde knop met een vlakke kant**, die het weggrollen op het werkblad voorkomt
- Stift met kleine vleugels die het verdraaien in de stiftopnameschacht voorkomen
- Schachtmaat: 3,0 mm, stiften gevleugeld



1682 .. | 110 mm

1682 01	1682 00	1682 10	1682 14	1682 18	1682 20	1682 23
Groen	Groen	Grijs	Blauw	Rood	Zwart	Zwart
						
						
Bladbreedte: ⊕ 1,5 mm	Bladbreedte: ⊕ 2,0 mm	Bladbreedte: ⊖ 1,0 mm	Bladbreedte: ⊖ 1,4 mm	Bladbreedte: ⊖ 1,8 mm	Bladbreedte: ⊖ 2,3 mm	Bladbreedte: ⊖ 2,3 mm
Reservestift: 1682 46	Reservestift: 1682 45	Reservestift: 1682 30	Reservestift: 1682 34	Reservestift: 1682 38	Reservestift: 1682 40	Reservestift: 1682 43
						Reservestiften: Schachtmaat 3,0 mm, stiften gevleugeld
						 3 stuks

Draaistander

- Met 6 schroevendraaiers van de B & S standaardserie 1682 ..
- 4 gleufkopstiften 1,0; 1,4; 1,8; 2,3 mm
- 2 kruiskopstiften 1,5 en 2,0 mm

1682 61



Kunststofstander

- Met 6 schroevendraaiers van de B & S standaardserie 1682 ..
- 4 gleufkopstiften 1,0; 1,4; 1,8; 2,3 mm
- 2 kruiskopstiften 1,5 en 2,0 mm

1682 62













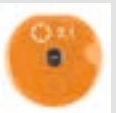

B & S Standaardserie moersleutels

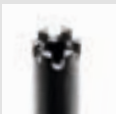
- Opnameschacht voor kruis- en gleufstiften en moersleutels
- Gegroefde handgreep voor optimale grip
- Gekleurde, **ronde knop met een vlakke kant**, die het weggrollen op het werkblad voorkomt
- Stift met kleine vleugels die het verdraaien in de stiftopnameschacht voorkomen
- Schachtmaat: 3,0 mm, stiften gevleugeld

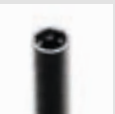

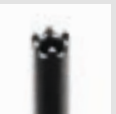
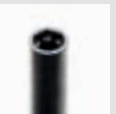
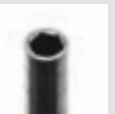
1682 ..  110 mm

1682 70	1682 72	1682 73	1682 74	1682 75	1682 76	1682 78	1682 79
 2,2 mm	 2,6 mm	 2,6 mm	 2,2 mm	 2,0 mm	 2,1 mm	 2,0 mm	 2,3 mm
							
Ster, 6 punts	Zeskant, voor grote moeren	Ster, 6 punts, voor grote stermoeren	Zeskant, voor kleine moeren	Ster, 4 punts	Ster, 6 punts, voor de meest gangbare moeren	Ster inbus, 6 punts	Zeskant, voor dopmoeren
Reservestift: 1682 80	Reservestift: 1682 82	Reservestift: 1682 83	Reservestift: 1682 84	Reservestift: 1682 85	Reservestift: 1682 86	Reservestift: 1682 88	Reservestift: 1682 89

 **Reservestiften:** Schachtmaat 3,0 mm, stiften gevleugeld

 2 stuks



Draaistander

- Met 8 moersleutels van de B & S standaardserie 1682 ..
- 4 zeskant 2,0; 2,2; 2,3; 2,6 mm
- 4 ster 2,0; 2,1; 2,2; 2,6 mm

1682 91



Kunststofstander

- Met 8 moersleutels van de B & S standaardserie 1682 ..
- 4 zeskant 2,0; 2,2; 2,3; 2,6 mm
- 4 ster 2,0; 2,1; 2,2; 2,6 mm

1682 92



B & S Inbus schroevendraaiers standaardserie

- Stift met kleine vleugels, voorzien van schroefkap
- Gegroefde handgreep voor optimale grip
- Geleerde, **ronde knop met een vlakke kant**, die het wegrollen op het werkblad voorkomt
- Inbusleutel zeskant
- Schachtmaat: 3,0 mm

1684 .. | 110 mm



1684 13
Inbus 1,3



1684 15
Inbus 1,5



1684 20
Inbus 2,0



1684 21
Inbus 2,1

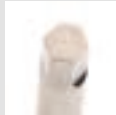
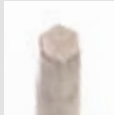

Reservestift:
1684 63

Reservestift:
1684 65

Reservestift:
1684 70

Reservestift:
1684 71

Reservestiften:
Schachtmaat 3,0 mm, stiften gevleugeld

 3 stuks















Torx schroeven
(zie pagina F 40)

B & S Torx schroevendraaiers standaardserie

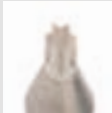
- Stift met kleine vleugels, voorzien van schroefkap
- Gegroefde handgreep voor optimale grip
- Geleerde, **ronde knop met een vlakke kant**, die het weggrollen op het werkblad voorkomt
- Torx sleutel voor schroeven met sterkop
- Schachtmaat: 3,0 mm

1684 .. | 110 mm



1684 32 Torx 2	1684 33 Torx 3	1684 34 Torx 4	1684 35 Torx 5	1684 36 Torx 6	
					
					
Reservestift: 1684 82	Reservestift: 1684 83	Reservestift: 1684 84	Reservestift: 1684 85	Reservestift: 1684 86	Reservestiften: Schachtmaat 3,0 mm, stiften gevleugeld
					 3 stuks



Torx schroevendraaierset

- Handgrepen serie 1682 .. inclusief stiften
- Schroevendraaierset in een praktische box
- Stiften met kleine vleugels, voorzien van schroefkap
- Blauwe draaiknop met opschrift, vereenvoudigd herkenning
- Geleerde, **ronde knop met een vlakke kant**, die het weggrollen op het werkblad voorkomt
- Met 4 schroevendraaiers: torx maten 3, 4, 5 en 6

1684 50



Schroevendraaier met magazijn in B & S Design

Met grote **ovale** draaibare knop en 5 stiften (in handgreepmagazijn).

De ovale draaiknop voorkomt het wegrollen van de schroevendraaier op het werkblad.

Schachtmaat: 2,5 mm

Bladbreedte: ● 1,0; 1,4; 1,8; 2,3 mm, ⊕ 2,0 mm

1666 00 | 119 mm | 35 g



Passende reservestiften Nr. 1711 ..
vindt u op pagina C 2.

Schroevendraaier met magazijn

Met kunststof greep, grote ronde draaibare knop en 5 stiften (in handgreepmagazijn).

Schachtmaat: 2,5 mm

Bladbreedte: ● 1,0; 1,4; 1,8; 2,3 mm, ⊕ 2,0 mm

1678 00 | 119 mm | 31 g



Passende reservestiften Nr. 1711 ..
vindt u op pagina C 2.

Schroevendraaier met magazijn

Als Nr. 1678 00, maar met 1 stift.

Schachtmaat: 2,5 mm

Bladbreedte: ● 1,8 mm

1690 00 | 119 mm | 21 g



Passende wisselstift Nr. 1711 18
vindt u op pagina C 2.

Universele schroevendraaier met magazijn

Van vernikkelde messing, met draaibare kunststof knop en 4 stiften.

Schachtmaat: 2,5 mm

Bladbreedte: ● 1,5; 1,8; 2,3 mm, ⊕ 2,0 mm

1717 00 | 115 mm | 30 g



Passende reservestiften Nr. 1711 ..
vindt u op pagina C 2.

Mini schroevendraaier

- Met 5 verschillende functies: gleufkopstift, kruiskopstift en 3 moersleutels
- Bladbreedte: ⚙ 1,8 mm, ⚙ 1,8 mm
- Moersleutels: 2,02; 2,32; 2,57 mm
- Kleuren: Blauw, Rood, Groen, Lila, Oranje

In foliezakje:

1798 16  10 stuks (elk 2 per kleur)



Toonbankdisplay

- Met 10 schroevendraaiers Nr. 1798 .., met 5 functies
- Afmeting: DIN A4

1798 56



Reservestiften

Bladbreedte = Schachtmaat	Vorm	Omschrijving	Passend op	Bestelnr.	
1,0 mm	⚙	Gleufkopstift	1662 10*, 1680 10*, 1700 10*	1693 10	3 stuks
1,5 mm	⚙	Gleufkopstift	1662 15*, 1680 15*, 1700 15*	1693 15	3 stuks
1,8 mm	⚙	Gleufkopstift	1662 18*, 1680 18*, 1700 18*	1693 18	3 stuks
2,3 mm	⚙	Gleufkopstift	1662 23*, 1680 23*, 1700 23*, 1723 ..	1693 23	3 stuks
1,0 mm	⚙	Gleufkopstift	1669 ..	1669 10	2 stuks
1,4 mm	⚙	Gleufkopstift	1669 ..	1669 14	2 stuks
1,8 mm	⚙	Gleufkopstift	1669 ..	1669 18	2 stuks
2,3 mm	⚙	Gleufkopstift	1669 ..	1669 23	2 stuks
2,0 mm	⚙	Kruiskopstift	1669 ..	1669 25	2 stuks
2,6 mm	⚙	Moersleutel zeskant groot	1669 ..	1669 42	2 stuks
2,6 mm	⚙	Moersleutel ster, 6 punts	1669 ..	1669 43	2 stuks
2,2 mm	⚙	Moersleutel zeskant klein	1669 ..	1669 44	2 stuks
2,0 mm	⚙	Moersleutel ster, 4 punts	1669 ..	1669 45	2 stuks
2,1 mm	⚙	Moersleutel ster, 6 punts	1669 ..	1669 46	2 stuks
2,8 mm	⚙	Moersleutel gleuf	1669 ..	1669 47	2 stuks
2,0 mm	⚙	Moersleutel ster inbus, 6 punts	1669 ..	1669 48	2 stuks
2,3 mm	⚙	Moersleutel zeskant, voor dopmoeren	1669 ..	1669 49	2 stuks
2,2 mm	⚙	Moersleutel ster 6 punts	1669 ..	1669 67	2 stuks
3,6 mm	⚙	Moersleutel gekarteld	1669 ..	1669 69	2 stuks

* uitverkocht



De set spreekt voor zich.

Uit het Zwarte Woud op uw werktafel. Volgens grootte gesorteerd in een beukenhouten doos. Zeven dunne moersleutels uit het beste werktuigstaal met 7 van de meest gebruikte sleutelkoppen. Deze worden in kleine aantallen gemaakt met de aanzet die typisch is voor B&S moersleutels. Deze aanzet voorkomt het lastige „verdwijnen” van de moer in de schacht. Het hoogwaardige gereedschapstaal garandeert een lange levensduur.

Moersleutelset

Inhoud 7 moersleutels:

Nr. 1742 00; 1743 00; 1744 00; 1745 00;
1746 00; 1748 00 en 1767 00

1741 15  13,5 x 2,4 x 12 cm



Ook afzonderlijk verkrijgbaar:

17. ...

 100 mm

 15 g

1742 00
○ 2,6 mm

1743 00
⊗ 2,6 mm

1744 00
○ 2,2 mm

1745 00
⊗ 2,0 mm

1746 00
⊗ 2,1 mm

1747 00
● 2,8 mm

1748 00
○ 2,0 mm

1749 00
○ 2,3 mm

1767 00
⊗ 2,2 mm

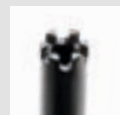
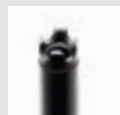
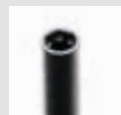
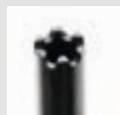

Greep Nr. 2
Zeskant, voor
grote moeren

Greep Nr. 3
Ster, 6 punts,
voor grote
stermoeren

Greep Nr. 4
Zeskant, voor
kleine moeren

Greep Nr. 5
Ster, 4 punts

Greep Nr. 6
Ster, 6 punts,
voor de meest
gangbare
moeren

Greep Nr. 7
Gleufkop

Greep Nr. 8
Ster inbus,
6 punts

Greep Nr. 9
Zeskant, voor
dopmoeren
0839 ..
0840 ..

Greep Nr. 0
Ster, 6 punts,
voor grote
moeren

Moersleutelset

Inhoud 5 moersleutels:

Nr. 1743 00; 1744 00; 1745 00; 1746 00 en 1748 00

1741 05  13,5 x 2,7 x 9,6 cm



Het gripnummer vereenvoudigt de toevoeging van het bestelnummer.

Afgebroken? Geen probleem!

Precisie en comfort gaan hier hand in hand. Afgebroken schroeven kunnen met dit handige werktuig zuiver en precies uitgedrukt worden. De Hand-CLAVULUS inzetten, de vleugelmoer aandraaien, en na enkele keren draaien is de afgebroken schroef al verwijderd.

Hand-CLAVULUS

- Voor het uitdrukken van afgebroken schroeven
- Compact en ergonomisch gereedschap
- Kracht is door de vleugelschroef precies te regelen
- Materiaalbesparend gebruik
- 3 verwisselbare hulzen voor verschillende schroefdiameters bij levering inbegrepen
- Massief en robuust materiaal (edelstaal)

1727 00



Schroevenverwijderaar met magazijn

De scherpe kanten van de stiften maken het mogelijk de rest van een afgebroken schroef te pakken en te verwijderen zonder het gebruik van een boormachine.

Schachtmaat: 2,5 mm

Levering incl. 2 stiften met diameter: 1,3 en 1,5 mm

1691 00 | 119 mm | 25 g



Reservestiften

Bladbreedte 1,3 mm

1691 13

Bladbreedte 1,5 mm

1691 15

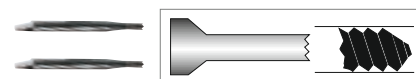

Aluminiumstander „Derde hand”

- Stabiele voet
- Met 3 verschillende stiften voor het vasthouden van schroeven en moeren
- Schachtmaat: 2,5 mm, klemstift

1 gleufkopstift: Bladbreedte: 2,3 mm

1 moersleutel (zeskant): Binnendiameter: 2,2 mm

1 moersleutels (ster, 6 punts): Binnendiameter: 2,1 mm

1723 00



Passende reservestiften Nr. 1711 .. vindt u op pagina C 2.

Aluminiumstander „Derde hand” met moerengrijper

- Een nieuwe combinatie van „derde hand” met moerengrijper
- Stabiele voet
- Voor het vasthouden van moeren voor het opdraaien
- Voor het probleemloos pakken van moeren

1723 20



Metaalstander „Derde hand”

- Stabiele voet
- Met 5 reservestiften en 7 functies voor het vasthouden van schroeven of moeren
- Schachtmaat: 3,15 mm, stiften gevleugeld

1 gleufstift met aan beide zijden een blad:

Bladbreedte: 1,5 en 1,8 mm

1 kruiskopstift met aan beide zijden een blad:

Bladbreedte: 1,5 en 1,8 mm

3 moersleutels (zeskant):

Binnendiameter: 2,0; 2,3 en 2,5 mm

1728 00

Aluminiumstander „Derde hand” extra hoog met grote stiften

- Stabiele voet
- Met 5 reservestiften en 7 functies voor het vasthouden van schroeven of moeren
- Schachtmaat: 3,15 mm, stiften gevleugeld

1 gleufstift met aan beide zijden een blad:

Bladbreedte: 1,5 en 1,8 mm

1 kruiskopstift met aan beide zijden een blad:

Bladbreedte: 1,5 en 1,8 mm

3 moersleutels (zeskant):

Binnendiameter: 2,0; 2,3 en 2,5 mm

1728 10

Reservestiftenset

Voor de metalen staander „Derde hand” Nr. 1728 00.

Bestaand uit 5 stiften.

1728 01



„Eenvoudige montage van veren met een flexscharnier” (zie pagina B 43)



Uitgekiend. Werkplek omringd met kwaliteit.

De aambeeldtoren wordt exclusief voor B & S gemaakt. Met zijn voor een aambeeld ongebruikelijke vorm biedt dit handige zwaargewicht een reeks praktische voordelen. Zijn massieve aluminium voet geeft stabiliteit, zijn handige vorm en grootte maken hem flexibel. Op het ronde werkvlak kunnen kleine herstellingen uitgevoerd worden, zonder de tafelrand te beschadigen. Dat maakt het aantrekkelijk om service opdrachten uit te voeren tijdens een adviesgesprek in de verkoopruimte. De uitsparing aan de bovenkant is geschikt om brilonderdelen neer te leggen. Wie de aambeeldtoren heeft leren kennen, wil niet meer zonder werken.



Aambeeldtoren

- Voor het verwerken van schroeven van sluitblokken, scharnieren en padsteunen
- Optimale stand door rubberen ring en massieve behuizing
- Met uitsparing voor brilonderdelen
- Rubberen beleg op het werkvlak, om het brilmateriaal te beschermen
- De aambeeldtoren kan met een standaard M6-schroef op het tafelblad bevestigd worden
- Voor de werkplaats en de verkoopruimte



1729 00



Voet x hoogte: 80 x 80 mm



300 g



Rubberen ring

1729 01



2 stuks

Opticiensaambeeld

- Hoogglans verchromd, met boring voor doorslag, ronde en rechthoekige spit

1730 10



120 x 45 x 25 mm



425 g



Schroevendraaierpincet

- Eenvoudige fixatie door sluitring
- De schroef wordt vastgehouden en kan ingeschroefd worden, optimaal bij flexscharnieren
- Draaibare knop aan het pinceteinde vergemakkelijkt inschroeven

1627 00



130 mm



30 g



Moerengrijper

- Houdt moeren zo vast dat ze op het schroefdraad gedraaid kunnen worden
- Voor het probleemloos pakken van **moeren**

1639 00 | 100 mm | 35 g



Schroevengrijper

- Aan beide zijden gegroefd voor het oppakken, vasthouden en indraaien van **schroeven**

1636 00 | 75 mm | 180 g



Pincet – klikpads

- Voor het verwijderen van klikpads
- Ook als tang verkrijgbaar

1626 00 | 100 mm | 15 g

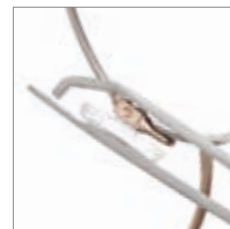

Onze tang nr. 1502 00 N en 1502 50 vindt u op pagina B 18.

Pincet – smalle spitsen

- Met smalle punten, roestvrij

1631 00 | 110 mm | 17 g



Pincet – puntig

- Puntig, vernikkeld

1621 00 | 110 mm | 18 g



Titanium soldeerpincet

- Voordelen: anti soldeerhechting, geringe warmtegeleiding, 100 % antimagnetisch, zeer zuurvast, extreem licht, met centreerstift

1623 10 | 160 mm | 15 g



Soldeer kruispincet

- Met houten vingergreep, staal, gepolijst

1624 00 | 160 mm | 35 g



Schroefhouder

Gebogen spitsen – met fixatie

- Aan beide zijden gegroefd voor het vasthouden van pad- en sluitblokschroeven
- Met een voorziening om de schroef te fixeren
- Gebogen spits, zeer geschikt voor moeilijk toegankelijke schroeven

1653 00 | 110 mm | 11 g



De klassieker

- Aan beide zijden gegroefd voor het vasthouden van pad- en sluitblokschroeven

1651 00 | 130 mm | 30 g



Fijne spitsen

- **RVS**, recht, aan beide zijden gegroefd
- Speciaal voor het vasthouden van padschroeven
- Voor het indraaien van de eerste slag van de schroefdraad

1634 00 | 105 mm | 10 g



Kruispincet

- Voor het indraaien van de eerste slag van de schroefdraad

1625 00 | 155 mm | 32 g

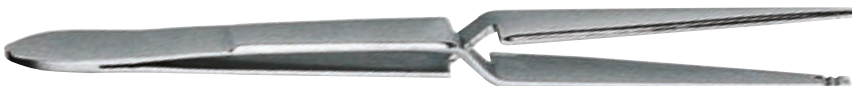

Schroefhouder met fixatie

- De fixatie zorgt voor een goede grip van de schroef
- Optimaal bij het monteren van de schroef in het scharnier

1637 00 | 135 mm | 30 g



Niethamer

- Blauwmetalen afwerking, ronde kop, met houten steel

1781 10

| 260 mm  80 g



Niethamer

- Metaal, bi-color, ronde kop, één kant metaal, andere kant plastic

1772 00

| 240 mm  100 g



Driekant holschaver

- Conisch, met greep

2071 00

| 165 mm  25 g



Slijpselverwijderaar voor kunststofglazen

- Voor het verwijderen van slijpsel bij polycarbonaat en Trivex glazen
- Verwijderen van restmateriaal na het groeven van glazen

2072 00

| 95 mm  10 g



Hand-groefschaver

- Voor zowel ruwe als gladde oppervlakken
- Verstelbaar voor elke groefbreedte

2073 10

| 145 mm  40 g





Glassnijder

- De traditionele „Zilversnede“, hoogwaardige kwaliteit „Made in Germany“



2634 00

130 mm 25 g

Snijlepel

- Voor het snijden van glas
- Volgens Ohlhanns systeem, naar de hand gezet model, metaal



2637 00

150 mm 30 g

Universele stalen snijwiel

- Hoogwaardige kwaliteit „Made in Germany“
- Passend op glassnijder Nr. 2634 00 en snijlepel Nr. 2637 00



Vergrote afbeelding

2239 00

∅ 4,5 mm 12 stuks

Veiligheidsmes met trapeziumvormig blad

- Het mes trekt zich automatisch terug na gebruik
- Handvat met rubber overtrokken
- Hoogwaardig trapeziumvormig blad
- Bladbreedte: 18 mm



1603 00

145 mm 65 g

Reservemessen voor Nr. 1603 00

- Bladbreedte: 18 mm

1603 01

60 mm 10 stuks



Universele schaar

- Met kunststof grepen voor moeiteloze bewerking van mallenplaatjes
- Eenzijdig vertande snede (gegolfd)
- Met slot tegen ongewenst openen

1607 10  145 mm  62 g



Kleine schaar

- Met rechte snede en geschroefd scharnier

1614 00  60 mm  18 g



Schaar

- Edelstaal, roestvrij
- Verstelbaar door schroef, voor links en rechtshandigen

1613 10  200 mm  90 g





Scalpel met metalen grip

- Praktisch snijinstrument voor inlegrand, nylondraad, folien etc.
- Door extreem scherp blad perfecte snijranden
- Metalen greep **met 3 stiften**
- Lengte snijvlak: 35 mm

1602 10  150 mm  15 g



Reservemessen voor Nr. 1602 10

1602 15  35 mm  3 stuks



Scalpel set

- Ideaal voor het snijden van bijvoorbeeld nylon draden
- Inhoud: 1 greep en 8 messen in diverse vormen en maten

1604 00  160 x 30 x 65 mm  120 g



Ruimers

- 5 kant, smal geslepen, **zonder houder**, met schacht

2051 ..  3 stuks

Bestelnr.	∅	Bestelnr.	∅
2051 31	1,0 mm	2051 36	1,7 mm
2051 32	1,1 mm	2051 37	1,9 mm
2051 33	1,2 mm	2051 38	2,0 mm
2051 34	1,3 mm	2051 39	2,2 mm
2051 35	1,6 mm		



Ruimerassortiment

- Ruimers 5 kant, smal geslepen, **met geruwde handgreep**
- Ruimers-∅: 1,0; 1,1; 1,2; 1,4; 1,6 en 1,8 mm

2053 00  25 g  6 stuks



Ruimerassortiment voor soldeernaalden



- Met kunststof handgreep, voor het reinigen van vervuilde soldeernaalden
- Ruimers-∅: 0,05; 0,08; 0,10; 0,15; 0,20; 0,25; 0,30; 0,35; 0,40; 0,45; 0,50 en 0,55 mm

2840 20  11 g  12 stuks



Ruimerassortiment

- Ruimers, 5 kant, smal geslepen, **zonder houder**, **met** schacht en **met** metalen houder
- Inhoud:** Nr. 2051 31; 2051 32; 2051 33; 2051 34; 2051 35; 2051 36; 2051 37; 2051 38 en 2051 39

2050 00  30 g  12 stuks



Tap

- Met 3 geslepen en geharde groeven, hoogwaardige uitvoering
- Besteladvies: zie tabel

1962 ..  3 stuks



Vergrote afbeelding

Taphouder

- Kunststof, genummerd met overeenstemmende tapmaat
- Besteladvies: zie tabel

1736 ..  85 mm  10 g



Tapdraad	Schachtmaat	Bestelnr. voor tap	Bestelnr. voor taphouder
M 0,80 mm	1,45 mm	1962 08	1736 08
M 1,00 mm	1,45 mm	1962 10	1736 10
M 1,10 mm	1,45 mm	1962 11	1736 11
M 1,20 mm	1,45 mm	1962 12	1736 12
M 1,30 mm	1,45 mm	1962 13	1736 13
M 1,40 mm	1,45 mm	1962 14	1736 14
M 1,50 mm	1,75 mm	1962 15	1736 15
M 1,60 mm	1,95 mm	1962 16	1736 16
M 1,70 mm	1,95 mm	1962 17	1736 17
M 1,80 mm	2,00 mm	1962 18	-

Tappenassortiment

- In houten cassette
- Inhoud:** 9 gebruiksklare tappen in de maten: M 0,80; M 1,00; M 1,10; M 1,20; M 1,30; M 1,40; M 1,50; M 1,60; M 1,70; 1 voorsteekdoorn Nr. 1780 00 en 1 leeg vak

1980 00



Tappenassortiment



- Inhoud:** Elk 3 tappen Nr. 1962 08; 1962 10; 1962 12; 1962 13; 1962 14 en taphouder Nr. 2062 00

1981 00



Boringmeter 1,0 tot en met 1,6

- Voor snelle, tijdbesparende meting van boringen in brillenglazen
- Met afgeronde spitsen voor eenvoudig meten
- Hoogwaardige uitvoering
- 6 doornen in de maten: 1,0; 1,2; 1,3; 1,4; 1,5 en 1,6 mm

1718 11  Buiten: 65 mm  10 g



Boringmeter 1,0 tot en met 2,4

- Voor snelle, tijdbesparende meting van boringen in brillenglazen
- Met afgeronde spitsen voor eenvoudig meten
- Hoogwaardige uitvoering
- 10 doornen in de maten: 1,0; 1,2; 1,3; 1,4; 1,5; 1,6; 1,8; 2,0; 2,2 en 2,4 mm

1718 12  Buiten: 80 mm  26 g

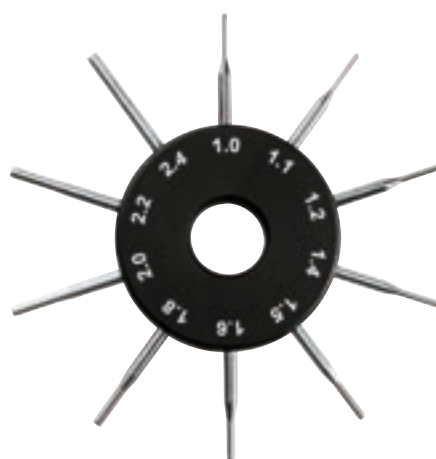

Voorsteekdoorn

- Ondersteuning bij het inschroeven van scharnieren
- Conisch
- Met kunststof handgreep

1718 00  105 mm  10 g



Reservestift

- Voor voorsteekdoorn Nr. 1718 00

1718 01



TIPS & TRICKS

HENRY – KLEINE HULP IN VELE SITUATIES

Bescherud drievoudig tegen krasseu

Glasbeschermer Henry van siliconen

Bestelnr. 2272 00

Opticiensschroevendraaiers

Bestelnr. 1664 ..

Precisievijl

Bestelnr. 1868 00

Zijkniptang

Bestelnr. 1579 00 N



elk ca. 3 minuten

Zo werkt het



Optie 1: Bij het verwisselen van neuspads

1 KLEMMEN



2 NEUSPADWISSEL



Optie 2: Bij het openen van een sluitblok

1 INLEGGEN



2 OPEN-/ DICHTSCHROEVEN



Optie 3: Bij het afkorten van glasbrilschroeven

1 KLEMMEN



2 AFKORTEN





3 VIJLEN



Glasbescherming Henry



- Beschermt het glas veelzijdig tegen krassen: tijdens de montage van pads, bij glasbrilboringen, bij werkzaamheden aan het sluitblok
- Materiaal: Siliconen

2272 00  60 x 80 mm  1 g  2 stuks



Montagehulp voor glasbrillen

- Afstand en beschermingsplaatje voor het eenvoudig inkorten van kunststofhulzen (1,4 en 1,8 mm) aan het glas
- Nylordraad (max. diameter 1,0 mm) kan direct aan het glas ingekort worden
- Geschikt voor het verwijderen van restmateriaal bij afgerande polycarbonaatglazen

2269 00  55 x 20 mm  1 g



Montagehulp voor glasbrillen met langwerpige openingen

- Afstand- en beschermingsplaatje voor het inkorten van hulzen
- Vergemakkelijkt het demonteren van de glasbril
- Verwijdert restmateriaal bij afgerande polycarbonaatglazen

2269 10  50 x 11 mm  1 g





TIPS & TRICKS

NYLORINLEGDRAAD INSTRUMENT

Eindelijk met plezier draad inleggen

Nylorinlegdraad instrument

Bestelnr. 1365 00

Pincet – smalle spitsen

Bestelnr. 1631 00

Nylordraadhaak

Bestelnr. 1719 00

Kleine schaar

Bestelnr. 1614 00



elk ca. 5 minuten

Zo werkt het



1 VERWIJDEREN



2 VERWIJDEREN



3 INRIJGEN



4 INBRENGEN

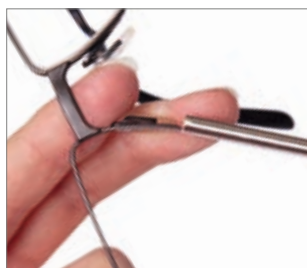

5 AFKNIPPEN



6 VASTZETTEN



7 INHAKEN



Nylorinlegdraad instrument

Voor het eenvoudig inbrengen van nylorinlegdraad- 8 profiel in de montuurrand.

- Totale lengte: 110 mm
- Diameter kogel: 15 mm
- Nylorinlegdraad: 0,51 mm en 0,55 mm

1365 00



Onze nylordraadhaak Nr. 1719 00 vindt u op pagina C 32.



Onze nylordraden vindt u op pagina F 85.

Nylordraadhaak

- Vergemakkelijkt het intrekken van nylordraad in de groef van het glas

1719 00 | 105 mm | 13 g



Montagehulp voor glasbrillen

- Voor het eenvoudig uitdrukken van montuuren hulsresten uit het brilleglas
- Passend voor alle monturen met 1,4 hulzen en gangbare boorgatafstanden

2267 10 Blauw | Ø 1,4 mm

75 x 10 x 25 mm | 7 g





TIPS & TRICKS

MONTAGEHULP VOOR GLASBRILLEN

Schroeven raudloos inkorten!

**Moersleutel en
schroevenkorter in één**

Voor schroeven met 1,2 mm draad
Bestelnr. 2268 00

Voor schroeven met 1,4 mm draad
Bestelnr. 2268 01



ca. 30 seconden

Zo werkt het

1 MONTAGE VAN DE MOER



2 GEREEDSCHAP OMDRAAIEN



3 BEVESTIGEN



4 AFKORTEN





5 KLAAR





Moersleutel en schroevenkorter in één

2268 ..  70 mm  6 g



2268 00 

- Voor het inkorten van schroeven met **1,2 mm** draad
- Voor alle gangbare zeskant moeren met een max. buitendiameter van **2,7 mm**

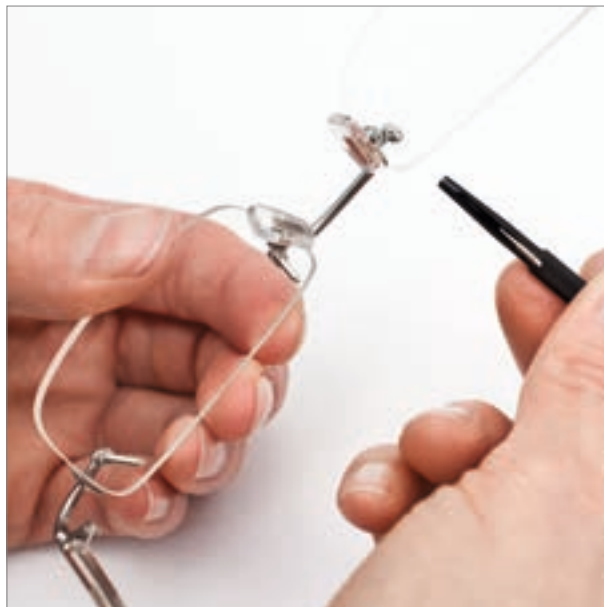

2268 01 

- Voor het inkorten van schroeven met **1,4 mm** draad
- Voor alle gangbare stermoeren met een max. buitendiameter van **2,5 mm**



Boorgatfrees

- Voor het vlot ontbramen van de kanten van boorgaten
- Door de speciale lancetvorm kunnen de kanten met weinig druk snel en effectief bewerkt worden
- Verzinken is geen probleem
- Optimaal en schoon resultaat door kloksgewijs draaien
- Wij adviseren de frees alleen voor kunststof, polycarbonaat en Trivex glazen te gebruiken

2266 20  71 mm  7 g



Gereedschapset voor glasbrillen

- Practische gereedschapset voor glasbrillen in een stabiele, hersluitbare verpakking
- Bestaat uit Nr. 2268 00 en 2268 01, montagehulp voor 1,2 mm en 1,4 mm schroefdraad en Nr. 2262 20 boorgatfrees met lancetvorm

2268 50



Boorgatfrees

- Passend voor gereedschaphouders Nr. 2069 00, 2068 00 en 2065 00
- Schachtmaat: **1,6 mm**

2266 10



Dubbele handverzinker met bakfrees en schroef eind frees

- Voor het bewerken van scharnierdelen en schroefinden

2216 00

122 mm  5 g



Duplexbak en veer handfrees

- Voor het bewerken van scharnierdelen aan duplexveren
- Freesboring: 3,5 mm

2220 04

110 mm  2 g



Schroeven handfrees

- Voor het affrezen van schroeven (behalve stalen schroeven)
- Schachtmaat: 2,5 mm

2271 25

110 mm  2 g



Siliconen mat

- Siliconen anti-slip mat beschermt bril en werkblad tegen krassen
- Ideaal voor de werkplaats en service afdeling
- Materiaal: Siliconen
- Dikte: 1,5 mm

2274 00  2 stuks



De gereedschappen Nr. 2217 03 (pagina C 36) 2216 00 en 2271 25 zijn voor de bewerking van handelsgebruikelijke nieuwzilveren en messing schroeven geschikt. Worden stalen schroeven bewerkt, dan leidt dat tot een directe beschadiging, waardoor de aanspraak op garantie vervalt.

Kleingereedschap assortiment

- Voor het bewerken van brilmonturen
- Inhoud:** 1 diamantfrees, 1 diamantfrees, 1 groeffrees, 1 slijpschijf (10 stuks) incl. opspandoorn, 2 frezen, 1 staalfrees, 1 rondborstel messing, 3 lappenschijven, 4 siliconen polijsters, 2 slijpschijven
- In praktische koffer
- Schachtmaat = 2,34 mm behalve
Nr. 2240 37 = schachtmaat: 3,0 mm



2240 57  68 x 58 x 66 mm  85 g



2264 00



2240 15



2240 37



2240 42



2240 41



2240 49



2240 25



2240 26



2240 07



2240 11



2240 31



2240 32



2240 33



2240 34



2240 19



2240 29



2240 18



Onze handboormachines vindt u vanaf pagina A 30.

Soort en vorm	Gebruik	Maten mm	Toerental tpm	Bestelnr.
Slijper, rond	Ongehard en gelegeerd staal	Ø 6 x 2,8	20.000–30.000	2240 07
Slijper, cilindrisch	Ongehard en gelegeerd staal	2,5 x 6,5	20.000–30.000	2240 11
Rondborstel messing	Bewerken van solderingen	21 x 1,8	10.000	2240 15
Gesiliconiseerde lappenschijf neteldoek	Voor het polijsten van kunststoffen	Ø 22	5.000	2240 18
Borstel, wol	Politoeren kunststof en keramiek	Ø 20	8.000	2240 19
Lappenschijf, flanel	Politoeren kunststof en metaal	Ø 20	5.000	2240 29
Siliconenpolijster, middel, naald	Metaal, kunststof en keramiek	4,5 x 12	7.000–10.000	2240 31
Siliconenpolijster, middel, rond	Metaal, kunststof en keramiek	11 x 2	7.000–10.000	2240 32
Siliconenpolijster, fijn, naald	Hoogglans op metaallegeringen	5 x 10	7.000–10.000	2240 33
Siliconenpolijster, rond	Hoogglans op metaallegeringen	14 x 2,5	7.000–10.000	2240 34
Groeffrees, facet	Nabewerken glasgroeven	17 x 2,8	2.000–4.000	2240 37
Staalfrees, knop	Metaal, kunststof en hout	Ø 6	8.000–12.000	2240 41
Slijpschijf (10 stuks) incl. opspandoorn	Doorslijpen metaal en kunststof	22 x 0,8	30.000	2240 42
Diamantslijper, conisch	Slijpen en afvlakken	Ø 1,6	30.000	2240 49
Diamantfrees	Kerven van glasranden	5 x 0,6	15.000–18.000	2264 00
Slijprol, grof	Bewerken van metaal, plastic en hout	Ø 25	10.000	2240 25
Slijprol, fijn	Bewerken van metaal, plastic en hout	Ø 25	10.000	2240 26

Spiraalboren, HSS speciaal

- Voor het uitboren van stalen schroeven, voor titaniumboringen evenals voor boringen in kunststoffen zoals CR-39- en verloopglazen
- Afgestemd op de bewerking van harde materialen
- Zeer lange standtijd
- Toerental: **1.400 tot 10.000 tpm**
- Te gebruiken voor: **Kunststoffen, polycarbonaat, staal, titanium en edelmetalen**
- Schachtmaat: **2,34 mm**
- Deze boren zijn ook als assortiment **Nr. 2038 50** (zie onder) leverbaar

2038 ..  2 stuks

Bestelnr.	Boring
2038 05	0,5 mm
2038 06	0,6 mm
2038 07	0,7 mm
2038 08	0,8 mm
2038 09	0,9 mm
2038 10	1,0 mm
2038 11	1,1 mm
2038 12	1,2 mm
2038 13	1,3 mm
2038 14	1,4 mm
2038 15	1,5 mm
2038 16	1,6 mm



HSS spiraalboren set

- 12 hoogwaardige boren Nr. 2038 ..
- Inhoud:** Elk 2 spiraalboren, boring: 0,8; 1,0; 1,1; 1,2; 1,3 en 1,4 mm
- In praktische klapboxset

2038 50

 124 x 21 x 113 mm

 115 g

Spiraalboren, HSS

- Met cilindrische schacht, rechtssnijdend
- Toerental: **500 tot 3.000 tpm**
- Te gebruiken voor: **Kunststoffen en edelmetalen**

2032 ..  3 stuks

Bestelnr.	Schachtmaat	Boring
2032 05	0,5 mm	0,5 mm
2032 06	0,6 mm	0,6 mm
2032 07	0,7 mm	0,7 mm
2032 08	0,8 mm	0,8 mm
2032 09	0,9 mm	0,9 mm
2032 10	1,0 mm	1,0 mm
2032 11	1,1 mm	1,1 mm
2032 12	1,2 mm	1,2 mm
2032 13	1,3 mm	1,3 mm
2032 14	1,4 mm	1,4 mm
2032 15	1,5 mm	1,5 mm
2032 16	1,6 mm	1,6 mm
2032 17	1,7 mm	1,7 mm
2032 18	1,8 mm	1,8 mm
2032 20	2,0 mm	2,0 mm



Spiraalboren set, HSS 30-delig

- Inhoud:** Elk 3 spiraalboren, in de maten: 0,5; 0,6; 0,7; 0,8; 0,9; 1,0; 1,1; 1,2; 1,3 en 1,4 mm
- In praktische klapboxset

2032 50

 210 x 18 x 113 mm

 140 g

Hardmetaalboren

- Voor het uitboren van stalen schroeven uit scharnieren
- Toerental: **10.000 tot 15.000 tpm**
- Te gebruiken voor: **Stalen schroeven**
- Schachtmaat: **2,34 mm**

2037 ..

Bestelnr.	Boring
2037 10	1,0 mm
2037 12	1,2 mm
2037 14	1,4 mm
2037 16	1,6 mm

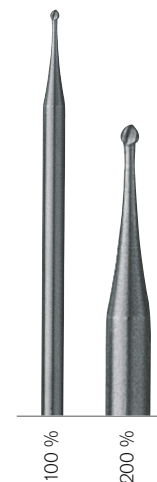

De boren Nr. 2037 .. zijn voorzien van een gelaste hardmetalen kop. Aanbevolen wordt een geringe werkdruk en koeling.

Boorfrezen voor NIDEK

- Voor NIDEK CNC machines ME en AHM
- Materiaal: **Wolframstahl**
- Schachtmaat: **3,16 mm**

2209 ..  10 stuks

Bestelnr.	Boring
2209 08	0,8 mm
2209 10	1,0 mm



Groevenfrees

- Voor het bewerken van kunststof- en metalen facetranden
- Schachtmaat: **2,35 mm**
- Diameter: **6 mm**
- Toerental: **ca. 6.000 tot 8.000 tpm**

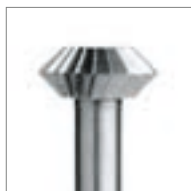

2240 44

Groevenfrees

- Voor het bewerken van kunststof- en metalen facetranden
- Schachtmaat: **2,35 mm**
- Diameter: **8 mm**
- Toerental: **ca. 6.000 tot 8.000 tpm**



2240 45

Groevenfrees voor kunststof monturen

- Voor het bewerken van de facetranden van een kunststof montuur
- Verstelbaar voor verschillende randmaten
- Schachtmaat: **3,12 mm**
- Toerental: **ca. 7.000 tot 8.000 tpm**
- Schijfdiameter: **10 x 2 mm**



2242 00



Hardmetaalboren voor kunststofglazen

- Gepolijste oppervlakken garanderen een zuiver snijbeeld
- Toerental: **1.000 tot 5.000 tpm**
- Te gebruiken voor: **Kunststoffen, polycarbonaat en Trivex**
- Schachtmaat: **3,175 mm**

2035 ..  38 mm

Bestelnr.	Boring	Bestelnr.	Boring
2035 08	0,8 mm	2035 16	1,6 mm
2035 09	0,9 mm	2035 17	1,7 mm
2035 10	1,0 mm	2035 18	1,8 mm
2035 11	1,1 mm	2035 19	1,9 mm
2035 12	1,2 mm	2035 20	2,0 mm
2035 13	1,3 mm	2035 21	2,1 mm
2035 14	1,4 mm	2035 22	2,2 mm
2035 15	1,5 mm	2035 23	2,3 mm



Hardmetaalborenset voor kunststofglazen

- **Inhoud:** 10 boren (0,8; 0,9; 1,0; 1,1; 1,2; 1,3; 1,4; 1,6; 1,8 en 2,0 mm)
- Kenmerken: zie boren hierboven
- Inclusief half-transparante kunststof box

2035 60  86 x 10 x 53 mm  60 g



Hardmetaalfrezen voor kunststofglazen

- Voor het kerven en frezen van kunststofglazen, polycarbonaat en Trivex
- Hoogwaardige dubbelsnijdende frezen, in **visstaartmodel geslepen**, de frezen kenmerken zich door een zuiver snijvlak en een lange standtijd
- Schachtmaat: **3,175 mm**

2212 ..  38 mm

Bestelnr.	Werkende lengte	Freesboring
2212 08	8,0 mm	0,8 mm
2212 09	9,0 mm	0,9 mm
2212 10	9,0 mm	1,0 mm
2212 11	9,0 mm	1,1 mm
2212 12	9,0 mm	1,2 mm
2212 13	9,0 mm	1,3 mm
2212 14	9,0 mm	1,4 mm
2212 16	10,0 mm	1,6 mm

dubbele snede



Onze boormachines vindt u vanaf pagina A 26.

Boren- en frezenset voor kunststofglazen

- **Inhoud:** 6 boren (0,8; 1,0; 1,2; 1,4; 1,6 en 2,0 mm) alsmede 4 frezen (1,0; 1,2; 1,4 en 1,6 mm)
- Kenmerken: zie boren 2035 .. en 2212 ..

2035 50  86 x 10 x 53 mm  60 g



Boorfrees voor kunststof glazen

- Deze boorfrees heeft een gepolijste oppervlakte voor een mooie afwerking
- Idiaal gebruik voor het perfect boren en frezen van kunststof, polycarbonaat en Trivex glazen
- Materiaal: **Wolfram staal**
- Schachtmaat: **3,14 mm**

2210 ..  38 mm

Bestelnr.	Werkende lengte	Boring
2210 08	6,0 mm	0,8 mm
2210 10	7,0 mm	1,0 mm
2210 12	7,0 mm	1,2 mm
2210 14	8,0 mm	1,4 mm
2210 16	8,0 mm	1,6 mm



Boorfreeset voor kunststofglazen

- Inhoud:** 5 boorfreesen (0,8; 1,0; 1,2; 1,4 en 1,6 mm)
- Kenmerken: zie boorfreesen hierboven
- Inclusief half-transparante kunststof box

2210 50  86 x 10 x 53 mm  43 g

Gediamanteerde boren

- Voor glas en keramiek
- Toerental: **ca. 20.000 tpm**
- Schachtmaat: **2,34 mm**

2044 ..

Bestelnr.	Werkende lengte	Boring
2044 10	7,0 mm	1,0 mm
2044 12	9,0 mm	1,2 mm

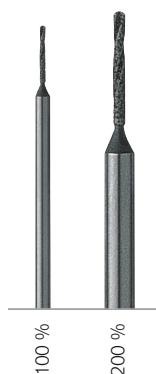

Diamantbezette boren

- Voor glas en keramiek
- Toerental: **15.000 tot 18.000 tpm**
- Werkende lengte: **6,0 mm**
- Schachtmaat: **2,34 mm**

2260 ..

Bestelnr.	Boring
2260 14	1,4 mm
2260 16	1,6 mm
2260 18	1,8 mm

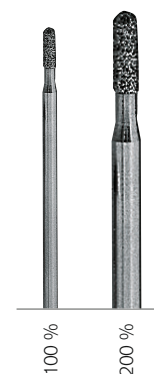

Diamant slijpschijf

- Afmetingen schijf: **22 x 0,60 mm**
- Toerental: **ca. 15.000 tot 18.000 tpm**
- Schachtmaat: **2,35 mm**

2263 00



Diamantfrees

- Voor het frezen van brillenglazen
- Voor gebruik in de schroeventovenaar Nr. 2886 70**
- Afmetingen schijf: **5,0 x 0,6 mm**
- Toerental: **ca. 15.000 tot 18.000 tpm**
- Schachtmaat: **2,35 mm**

2264 00



De diamantgereedschappen Nr. 2260 .., 2263 00 en 2264 00 zijn snelheidsgereedschappen en moeten op maximum toerental gedraaid worden. Het optimale toerental ligt tussen 15.000 en 18.000 tpm. Als koelmiddel **uitsluitend en véél water** gebruiken. Weinig druk uitoefenen zodat er altijd vrijloop mogelijk en slijtage gering is. Tijdens het boren meermaals stoppen om de boring te reinigen. Hoe **lager** het **toerental** hoe ruwer het resultaat. Hoe **hoger** het **toerental** hoe gladder het resultaat.



Duplexbak- en veerfrees

- Voor het bewerken van scharnierdelen aan duplexveren
- Freesboring: **3,0 mm**
- Schachtmaat: **3,0 mm**

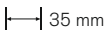
2217 03  35 mm



Kegelfrees

- Voor het frezen en verdiepen van strassstenen Nr. 0900 50 en 0900 51
- Voor het effenen van boringen in kunststofglazen
- Ook geschikt voor polycarbonaat en Trivex
- Schachtmaat: **2,34 mm**

2265 ..  44,5 mm



Bestelnr.	Freesboring
2265 19	1,9 mm
2265 23	2,3 mm
2265 27	2,7 mm
2265 40	4,0 mm

Verzinkfrees

- Voor het voorfrezen van verzonken scharnieren
- Freesboring: **5,0 mm**
- Schachtmaat: **3,0 mm**

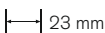
2237 50  23 mm



Bekijk ook eens ons assortiment strassstenen op pagina F 47.

Schroefefrees

- Geschikt voor **stalen**, messing en nieuwzilveren schroeven
- Buitendiameter: **1,8 mm**
- Binnendiameter: **1,4 mm**
- Schachtmaat: **2,34 mm**

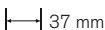
2215 18  37 mm



Hardmetaal frees

- Voor het bewerken van metaal en kunststof
- Schachtmaat: **3,0 mm**
- Diameter: **6 x 48 mm**
- Toerental: **ca. 4.000 tot 6.000 tpm**

2243 00



Scharnierfrees

- Voor het uitfrezen van scharnieraanzetten
- 4 snijvlakken
- Schachtmaat: **3,0 mm**



2236 ..  35 mm



Boorfrees

- Voor het kerven en frezen van lange boringen in kunststofglazen
- Ook geschikt voor polycarbonaat en Trivex
- Schachtmaat: **2,35 mm**

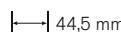
2211 ..

 44,5 mm  2 stuks



Bestelnr.	Freesboring
2236 30	3,0 mm
2236 35	3,5 mm
2236 40	4,0 mm
2236 45	4,5 mm
2236 50	5,0 mm

Bestelnr.	Werkende lengte	Freesboring
2211 08	3,5 mm	0,8 mm
2211 10	4,0 mm	1,0 mm
2211 12	4,2 mm	1,2 mm
2211 14	4,5 mm	1,4 mm
2211 21	5,1 mm	2,1 mm

Gereedschaphouder

- Met kunststof handgreep en draaibare kunststof knop, speciaal voor tappen
- Spanbereik: **1,5 tot 2,0 mm**

2062 00 | 90 mm | 10 g



Ruimerhouder

- Messing vernikkeld
- Spanbereik: **1,0 tot 2,0 mm**

2065 00 | 80 x 6 mm | 15 g



Gereedschaphouder

- Met 2 verwisselbare, hardstalen spantangen, vierkante kop
- Spanbereik: **0,7 tot 1,0 en 1,4 tot 2,4 mm**

2068 00 | 90 mm | 25 g



Snelspan vijlheft

- Snelspan heft voor naaldvijlen, diamantvijlen en de kleinere werkplaats- en precisievijlen
- Door eenvoudig beide helften te draaien klemt de vijl veilig in
- Spanbereik: **3,0 tot 3,75 mm**

2066 00 | 90 mm | 26 g



Precisie gereedschaphouder

- 2 verwisselbare stalen spantangen
- Zwarte kunststof handgreep met draaibare kop
- Tweede spantang in handgreepmagazijn**
- In de holle ruimte van de handgreep kunnen ook andere werktuigen opgeborgen worden
- Spanbereik: **0 tot 1,5 en 1,5 tot 2,5 mm**

2069 00 | 100 mm | 37 g



Precisie gereedschaphouder

- Met extra groot spanbereik
- Voor werktuigen met een schachtdiameter van maximaal 3,2 mm
- In de holle ruimte van de handgreep kunnen ook andere werktuigen opgeborgen worden
- Spanbereik: **2,5 tot 3,2 mm**

2070 00 | 100 mm | 34 g



Swiss Made en exclusief bij B & S.

Aan het uiterlijk ziet men de bijzondere kwaliteit van deze 2 in 1 precisie vlakvrijen met 2 verschillende kappen niet. Maar wie ze eenmaal gebruikt heeft, wil hun kracht niet meer missen. Een vergelijkbare kwaliteit zult u elders niet vinden.

Precisievijl vlak, klein, met handgreep

- Speciale B & S uitvoering
- Met twee verschillende kappen: Kap 1 = grof en kap 3 = middel
- Een derde van een smalle kant met kap
- Wordt geleverd met kunststof handgreep
- Kaplengte: 100 mm

1868 00

188 mm 2,8 mm 32 g

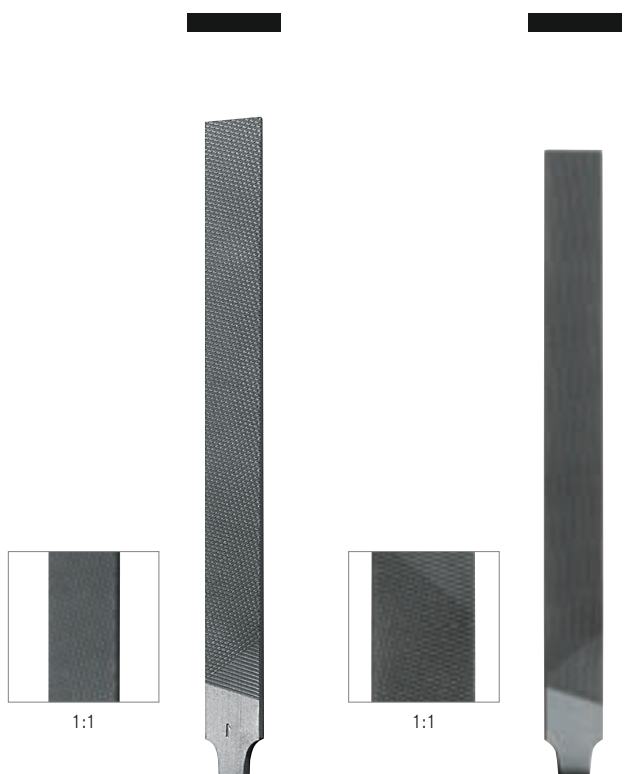

Precisievijl vlak, klein

- Speciale B & S uitvoering
- Met twee verschillende kappen: Kap 1 = grof en kap 3 = middel
- Een derde van een smalle kant met kap
- Kaplengte: 100 mm
- Passende handgrepen: Nr. 1735 80 en 1732 90

1867 00

143 mm 2,8 mm

22 g

Precisievijl vlak, groot

- Speciale B & S uitvoering
- Met twee verschillende kappen: Kap 1 = grof en kap 3 = middel
- Smalle kanten zonder kap
- Kaplengte: 120 mm
- Passende handgrepen: Nr. 1732 10 en 1735 10

1865 00

170 mm 3,2 mm

40 g



Voor reiniging adviseren wij vijlborstel Nr. 3516 00 op pagina E 33.

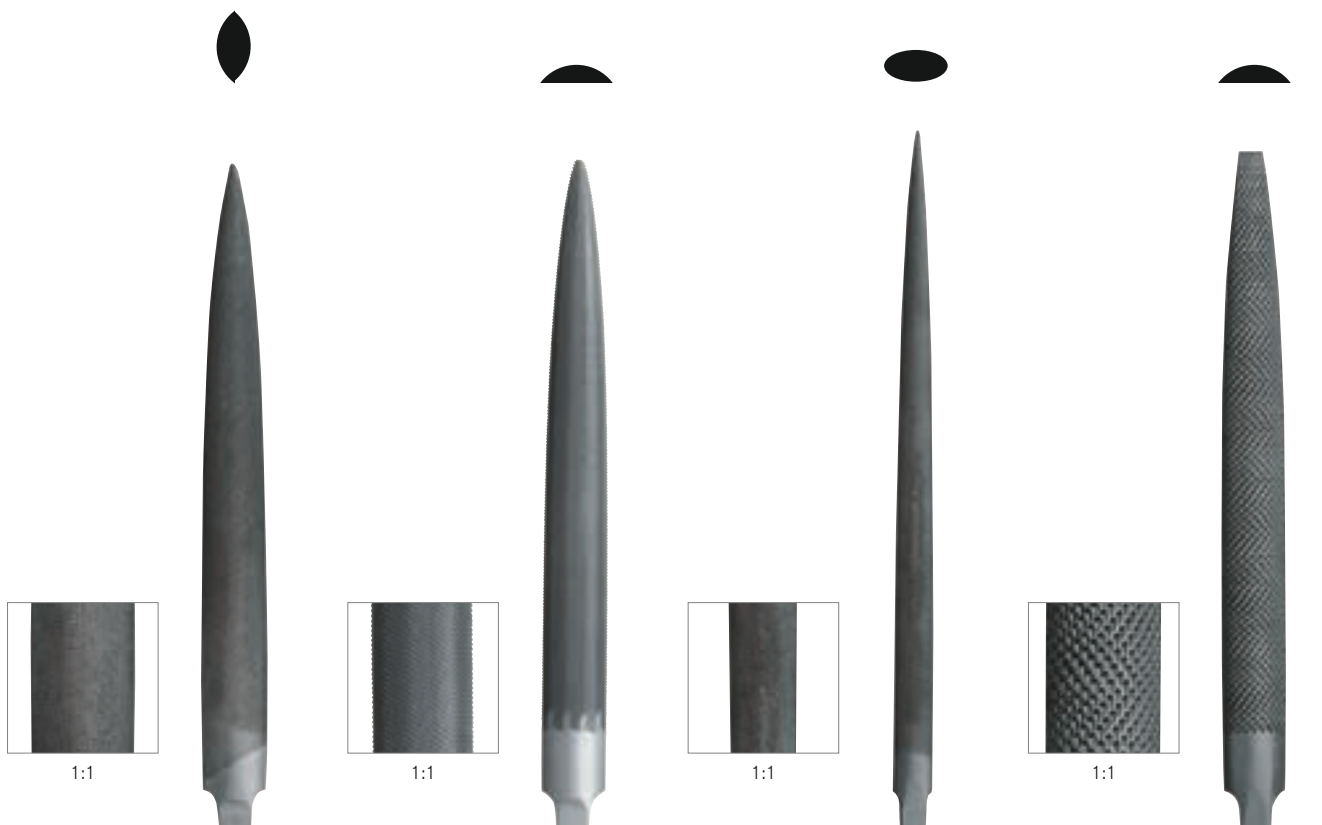

Precisievijl vogeltong

- Ovaal, conisch verloop naar voren
- Met smalle punt en heft
- Kap: 2
- Kaplengte: 125 mm
- Passende handgrepen: Nr. 1732 10 en 1735 10

1870 12

| 175 mm 38 g

Precisievijl half rond

- Met smalle punt en heft
- Kaplengte: 125 mm
- Passende handgrepen: Nr. 1732 10 en 1735 10

1878 01 Kap: 1

1878 02 Kap: 2

| 175 mm 38 g

Precisievijl ovaal

- Gelijkmatig gebogen
- Met afgeronde kanten
- Voor de bewerking van kunststof
- Kap: 3
- Kaplengte: 150 mm
- Passende handgrepen: Nr. 1732 10 en 1735 10

1882 13

| 205 mm 33 g

Rasp half rond

- Voor de bewerking van kunststof
- Met bijzonder fijne kap = 5
- Kaplengte: 150 mm
- Passende handgrepen: Nr. 1732 10 en 1735 10

1899 00

| 200 mm 55 g

Vijlheften

- Gelakt hout
- Standaarduitvoering, met kraag
- Opening: 4 mm



1732 90 | 90 mm 30 g

1732 10 | 100 mm 35 g

Vijlheft kunststof rood

- Mindert vermoeidheid en blaren
- Naar de hand gevormd
- Passend voor vijllengtes van 100 tot 150 mm
- Materiaal: slag- en glijvast kunststof
- Opening: 4-7 mm, boren niet nodig



1735 10 | 100 mm 34 g

Vijlheft kunststof blauw

- Ergonomisch vijlheft met soft-touch oppervlak
- Materiaal: tweecomponenten kunststof
- Opening: 3,7 mm



1735 80 | 85 mm 24 g

Naaldvijenassortiment

- Voor de bewerking van kunststoffen.
- In plastic, verschillende uitvoeringen (vlak, halfrond, driekant, vierkant, rond, vlak/spits)
- Kap: 2
- Kaplengte: 70 mm

1849 60 | 140 mm | 6 stuks



Naaldvijenassortiment

- Bijzonder kleine en handzame uitvoering met **extra fijne kap** voor de bewerking van kunststoffen.
- In plastic etui, verschillende uitvoeringen (vlak, halfrond, driekant, vierkant, rond en vlak/spits)
- Kap: 4
- Kaplengte: 50 mm

1848 50 | 100 mm | 6 stuks

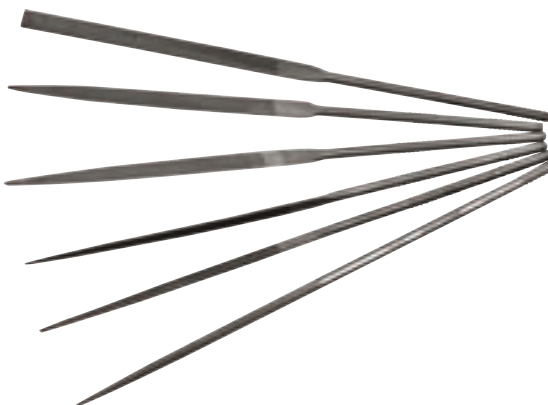

Naaldvijenassortiment

- Voor de bewerking van kunststoffen
- In plastic etui, verschillende modellen (vlak, halfrond, driekant, vierkant, rond, vlak/spits, vogeltong, mes)
- Gesorteerd in kap 1 en 3

1849 00 | 140 mm | 12 stuks



Diamant naaldvijenassortiment

- Voor de bewerking van **staal, glas en keramiek**
- In plastic etui, verschillende uitvoeringen (vlak, driekant, vierkant, rond, vlak/spits, ovaal, baret, vogeltong, halfrond, mes)
- Diamantbezette lengte: 50 mm

1801 50 | 140 mm | 10 stuks



Naaldvijlen

- Kap: 2

1849 ..  140 mm  2 stuks

1849 61 rond

1849 62 vlak

1849 64 driekant

1849 67 mesvorm



Mesvijl voor schroeven

- Zonder heft
- Kap: 5
- Kaplengte: 75 mm
- Randdikte: 0,30 mm



 75 x 9 mm

 0,55 mm

 3 g



Glasboring en scharniervijlen

- Rond, cilindrisch
- Kap: 3
- Kaplengte: 100 mm



 120 mm

 1 g



1853 10  1,1 mm

1853 13  1,3 mm

1853 16  1,6 mm

Ribbelvijl

- Vogeltongmodel
- Kap: 2



 180 mm

 28 g

1852 02

1860 15

Met kogelgewricht.

Deze bankschroef met nauwkeurige kogelgewrichtconstructie vindt u niet in de bouwmarkt. Hiermee kunnen de werkstukken in de gewenste posities gebracht worden, en draait u het werkstuk altijd zoals u het wilt. Met de verwisselbare kunststof bekken kunnen de werkstukken stevig en materiaalbesparend geklemd worden. Dit Duitse kwaliteitsproduct wordt slechts in kleine aantallen gemaakt. Een typisch B&S product.



Bankschroef met kogelgewricht

- Met zijdelings zwenkbereik en 360° draaibare voet
- Past zich aan elke noodzakelijke werkpositie aan
- Bekken: **Glad en verwisselbaar**
- Spandiepte: **38 mm**
- Bekbreedte: **50 mm**
- Spanwijdte: **48 mm**
- Max. dikte van de werktafel: **80 mm**

2106 00  1,5 kg

Kunststof bekken

- Passend voor Nr. 2106 00

2117 01  1 paar

Bankschroef

- Draaibare bankschroef met stalen bekken en kogelgewricht
- Van gietijzer met tafelklem
- Bekbreedte: **50 mm**
- Spanwijdte: **50 mm**
- Spandiepte: **32 mm**
- Max. dikte van de werktafel: **50 mm**

2107 00  2 kg



Bankschroef met kogelgewricht

- Instelbaar in elke willekeurige werkpositie
- Met rubberen beschermbekken
- Bekbreedte: **73 mm**
- Spanwijdte: **50 mm**
- Max. dikte van de werktafel: **55 mm**

2105 30  825 g



Viltbekken

- Voor bankschroef 2106 00, hechten d.m.v magneten aan de bekken

2121 10

 60 x 8 x 10 mm

 16 g

 1 paar



Aluminium bekken

- Eenvoudig in te hangen, passend voor elke bankschroef

2121 15

 65 x 10 x 14 mm

 33 g

 2 paar



Vijlblok

- Voor het vijlen van de veeraanslag, met tafelklem

1724 00  170 g

Beugelzaag klein

- Universeel te gebruiken (voor metaal en kunststof)
- Voor het snel doorzagen en afkorten van verschillende materialen
- Ideaal om speciale werkzaamheden met de figuurzaag voor te bereiden
- Geklemde zaag in beugel
- Beugeldiepte: 65 mm

2152 00  295 mm



Figuurzaag werkset

- Voor hout en kunststof
- **Inhoud:** 1 figuurzaaghouder, 1 figuurzaagblok met klem en 1 set figuurzagen

2151 00  390 g



Figuurzaagbladen

- Voor kunststof, plexiglas en zachte non-ferro metalen
- Eenzijdig snijdend
- Lengte: 130 mm

2198 ..  elk 12 stuks

2198 01  0,8 mm 2198 03  1,5 mm

2198 02  1,2 mm



Figuurzaagbladen

- Voor metaal
- Eenzijdig snijdend
- Lengte: 130 mm



2196 ..  elk 12 stuks

2196 01  0,5 mm 2196 03  1,0 mm

2196 02  0,7 mm





Standaard zaagblad voor beugelzaag klein

2152 10  150 mm  10 stuks





Figuurzaagblok (zonder afbeelding)

- Met 2 klemmen

2160 00  220 x 14 x 90 mm  16 g

Reserveschroeven set (zonder afbeelding)

- Voor de figuurzaaghouder, compleet met sluitring en vleugelmoer
- 1 set bevat: 2 vleugelmoeren, 2 sluitringen en 2 schroeven

2158 01  9 g  2 stuks

Reserveklemmen (zonder afbeelding)

2160 01  2 stuks

Figuurzaagbladen

- Voor kunststof
- Rondom snijdend
- Lengte: 130 mm

2199 ..  elk 12 stuks

2199 03  0,8 mm 2199 05  1,0 mm

2199 04  0,9 mm 2199 07  1,2 mm







OFTALMOLOGIE

Instrumenten voor de juiste diagnose



- D 2 Pasbrillen
- D 5 Pasdozen
- D 8 Kruiscilinders en balanslinialen
- D 10 Occluder & kleurtafels
- D 11 Tips & tricks: Prismafoliën
- D 12 Foliën
- D 13 Leesdelen
- D 14 Oogdoppen
- D 15 Occlusiefoliën
- D 16 KAANS Patch®
- D 17 Veiligheidsbrillen assortiment
- D 18 Contactlens accessoires
- D 22 Sferometers en diktemeters
- D 24 Schuifmaat
- D 26 Tips & tricks: The Cube
- D 28 Linialen

„Pasbril in perfectie” Oculus pasbrillen, natuurlijk „Made in Germany”.



Hypo-allergene kunststof, gebruiksvriendelijk en comfortabel om te dragen dat alles maakt de spreekwoordelijke kwaliteit.

Oculus pasbrillen

- Voor pasglazen met een diameter van 38 mm
- PD bereik 46 tot 80 mm
- Padinclinatie en hoogte verstelbaar
- Dermatologisch veilig materiaal (**anti-allergisch**)

UB6

- Ruimte voor een totaal van 12 pasglazen
- Stappen van 2,5° voor betere afleesbaarheid
- Flexibele dubbele oortips voor een perfecte pasvorm



4428 00  60,2 g

 **Onderdelen** verkrijgbaar bij uw leverancier.

Gepolariseerde Clip-on

Voor montage op de zijkant van pasbril Nr. 4428 00.

4428 50 Polarisatie = Circulair

4428 51 Polarisatie = V-positie (45°/135°)

4428 5.

 1 paar (links en rechts)



Gepolariseerde voorhanger

polarisatie = V positie (45°/135°)

4458 30  17 g



UB4

- Ruimte voor een totaal van 10 pasglazen
- Flexibele en anatomische aanpasbare veren
- Tijdloos vriendelijk design

4423 00  70 g

 **Onderdelen** verkrijgbaar bij uw leverancier.

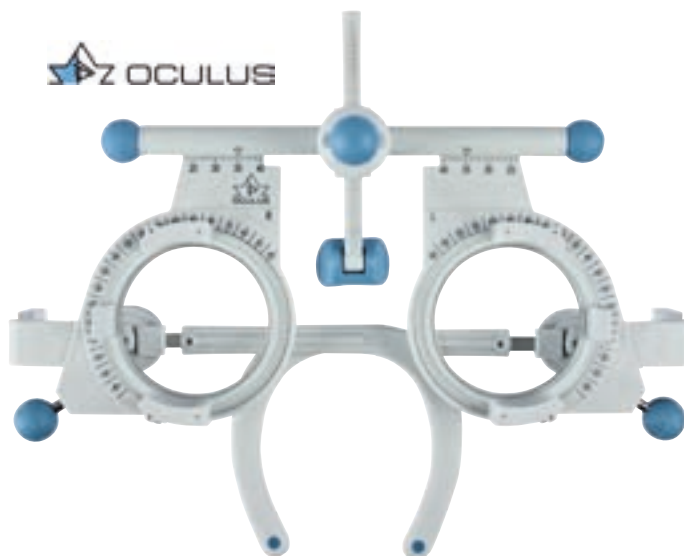

Gepolariseerde Clip-on

Voor montage op de zijkant van pasbril Nr. 4423 00.
Polarisatie = V-positie (45°/135°)

4423 51

 1 paar (links en rechts)

 Z OCLUS



Gepolariseerde Clip-on

Voor montage op de zijkant van pasbril Nr. 4423 00.
Polarisatie = Circulair

4423 50

 1 paar (links en rechts)

 Z OCLUS



Gepolariseerde Clip-on

- Kunststof randen
- Randdiameter: 38 mm
- Lensdiameter: 21 mm
- Polarisatie: Circulair
- Geschikt voor 3D refractie

4458 20

 1 paar (links en rechts)

 Z OCLUS



Universele pasbril

- Ruimte voor 10 pasglazen (Ø 38 mm)
- PD bereik 50 tot 80 mm
- Meetmogelijkheid voor de hoornvliesafstand
- Veerinclinatie en lengte verstelbaar
- Padinclinatie en hoogte verstelbaar
- Neusbrug en oortips in extra zachte uitvoering
- Inclusief 2 reserve neusbruggen, maten S en M
- Kleur: Zwart
- Levering in B & S design box

4427 00  61 g

 **Onderdelen** verkrijgbaar bij uw leverancier.



Universele pasbril

- Met verbeterde neussteun
- Ruimte voor 8 pasglazen (Ø 38 mm)
- PD bereik 48 tot 80 mm
- Meetmogelijkheid voor de hoornvliesafstand
- Veerinclinatie en lengte verstelbaar
- Padinclinatie en hoogte verstelbaar
- Neusbrug en oortips in extra zachte uitvoering
- Inclusief 2 reserve neusbruggen
- Kleur: Zwart
- Levering in B & S design box

4426 00  80 g

 **Onderdelen** verkrijgbaar bij uw leverancier.



Universele pasbril

- Vederlichte uitvoering
- Ruimte voor 8 pasglazen (Ø 38 mm)
- PD bereik 50 tot 80 mm
- Veerinclinatie en lengte, padhoogte individueel verstelbaar
- Kleur: Anthraciet
- Levering in kunststof box

4429 00  52 g

 **Onderdelen** verkrijgbaar bij uw leverancier.

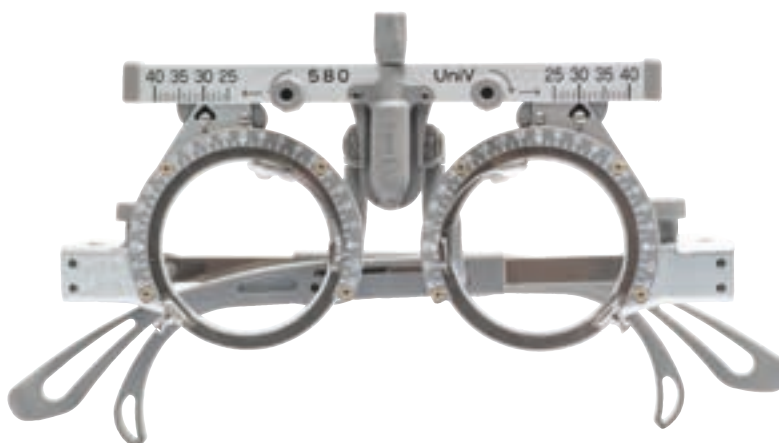

Pasdoos met 268 pasglazen met metalen vattingen

- Levering in hoogwaardige metalen koffer
- Passend voor standaard meetbrillen met 38 mm glazen
- Alle glazen kunnen afzonderlijk worden nabesteld

4369 05  54 x 10 x 35 cm  6,6 kg

 **Onderdelen** verkrijgbaar bij uw leverancier.



Inhoud van de pasdoos

elk 40 paar plus- en minglazen:

- ± 0,12 dpt.
- ± 0,25 dpt. tot ± 6,00 dpt. per 0,25
- ± 6,50 dpt. tot ± 10,00 dpt. per 0,50
- ± 11,00 dpt. tot ± 14,00 dpt. per 1,00
- ± 16,00 dpt. tot ± 20,00 dpt. per 2,00

elk 21 paar plus- en min cylinders:

- ± 0,12 dpt.
- ± 0,25 dpt. tot ± 4,00 dpt. per 0,25
- ± 4,50 dpt. tot ± 6,00 dpt. per 0,50

14 prismaglazen:

- 0,50 prdpt. (2 stuks) per 0,50
- 1,00 prdpt. tot 4,00 prdpt (2 stuks) per 1,00
- 5,00 prdpt. tot 6,00 prdpt (1 stuk) per 1,00
- 8,00 prdpt. tot 10,00 prdpt (1 stuk) per 2,0

10 extra glazen:

- 1x afdekschijf/zwart
- 1x diafragma – klein
- 1x diafragma – groot
- 1x sleufdiafragma
- 1x geribbeld glas
- 1x centreerkruis
- 1x planglas
- 1x rood
- 1x groen
- 1x kruiscylinder 0,25 dpt.

Pasdoos met 260 pasglazen met metalen vattingen en super-ontspiegeling

- Levering in hoogwaardige metalen koffer
- Passend voor standaard meetbrillen met 38 mm glazen
- Alle glazen kunnen afzonderlijk worden nabesteld

4369 10  54 x 10 x 35 cm  6,6 kg

 **Onderdelen** verkrijgbaar bij uw leverancier.



Inhoud van de pasdoos

elk 39 paar plus- en min glazen:

- ± 0,25 dpt. tot ± 6,00 dpt. per 0,25
- ± 6,50 dpt. tot ± 10,00 dpt. per 0,50
- ± 11,00 dpt. tot ± 14,00 dpt. per 1,00
- ± 16,00 dpt. tot ± 20,00 dpt. per 2,00

elk 20 paar plus- en min cylinders:

- ± 0,25 dpt. tot ± 4,00 dpt. per 0,25
- ± 4,50 dpt. tot ± 6,00 dpt. per 0,50

14 prismaglazen:

- 0,50 prdpt. (2 stuks) per 0,50
- 1,00 prdpt. tot 4,00 prdpt (2 stuks) per 1,00
- 5,00 prdpt. tot 6,00 prdpt (1 stuk) per 1,00
- 8,00 prdpt. tot 10,00 prdpt (1 stuk) per 2,00

10 extra glazen:

- 1x afdekschijf/zwart
- 1x diafragma – klein
- 1x diafragma – groot
- 1x sleufdiafragma
- 1x geribbeld glas
- 1x centreerkruis
- 1x planglas
- 1x rood
- 1x groen
- 1x kruiscylinder 0,25 dpt.

Pasdoos met 260 pasglazen met kunststof vattingen

- Levering in hoogwaardige metalen koffer
- Passend voor standaard meetbrillen met 38 mm glazen
- Alle glazen kunnen afzonderlijk worden nabesteld

4369 20  54 x 10 x 35 cm  5,5 kg

 **Onderdelen** verkrijgbaar bij uw leverancier.



Inhoud van de pasdoos

elk 39 paar plus en min glazen:

- ± 0,25 dpt. tot ± 6,00 dpt. per 0,25
- ± 6,50 dpt. tot ± 10,00 dpt. per 0,50
- ± 11,00 dpt. tot ± 14,00 dpt. per 1,00
- ± 16,00 dpt. tot ± 20,00 dpt. per 2,00

elk 20 paar plus- en min cylinders:

- ± 0,25 dpt. tot ± 4,00 dpt. per 0,25
- ± 4,50 dpt. tot ± 6,00 dpt. per 0,50

14 prismaglazen:



- 0,50 prdpt. (2 stuks)
- 1,00 prdpt. tot 4,00 prdpt. (2 stuks) per 1,00
- 5,00 prdpt. tot 6,00 prdpt. (1 stuk) per 1,00
- 8,00 prdpt. tot 10,00 prdpt. (1 stuk) per 2,00

10 extra glazen:

- 1 x afdekschijf/zwart
- 1 x diafragma – klein
- 1 x diafragma – groot
- 1 x sleufdiafragma
- 1 x geribbeld glas
- 1 x centreerkruis
- 1 x planglas
- 1 x rood
- 1 x groen
- 1 x kruiscylinder 0,25 dpt

Pasdoos met 159 pasglazen et metalen vattingen

- Levering in hoogwaardige metalen koffer
- Passend voor standaard meetbrillen met 38 mm glazen
- Alle glazen kunnen afzonderlijk worden nabesteld

4369 40  52,5 x 6,8 x 30 cm  5 kg

 **Onderdelen** verkrijgbaar bij uw leverancier.



Inhoud van de pasdoos

elk 25 paar plus- en min glazen:

- ± 0,25 dpt. tot ± 4,00 dpt. per 0,25
- ± 4,50 dpt. tot ± 6,00 dpt. per 0,50
- ± 7,00 dpt. tot ± 10,00 dpt. per 1,00
- ± 12,00 dpt.

elk 11 paar plus- en min cylinders:

- ± 0,25 dpt. tot ± 2,00 dpt. per 0,25
- ± 2,50 dpt. tot ± 3,00 dpt. per 0,50
- ± 4,00 dpt.

8 prismaglazen:



- 0,50 prdpt. tot 1,00 prdpt (2 stuks) per 0,50
- 2,00 prdpt. tot 5,00 prdpt (1 stuk) per 1,00

7 extra glazen:

- 1 x afdekschijf/zwart
- 1 x diafragma
- 1 x sleufdiafragma
- 1 x centreerkruis
- 1 x rood
- 1 x groen
- 1 x kruiscylinder 0,25 dpt.

Uitbreidingsset met 8 x 0,12 dpt. pasglazen met metalen vattingen



- 1 paar plus- en minusglazen
- 1 paar plus- en minuscilinders
- Passend voor standaard meetbrillen met 38 mm glazen
- Alle glazen kunnen afzonderlijk nabesteld worden

4369 02  22 x 2,5 x 12,5 cm  142 g



Uitbreidingsset met 8 x 0,12 dpt. pasglazen met kunststof vattingen

- 1 paar plus- en minusglazen
- 1 paar plus- en minuscilinders
- Passend voor standaard meetbrillen met 38 mm glazen
- Alle glazen kunnen afzonderlijk nabesteld worden

4369 22  22 x 2,5 x 12,5 cm  114 g



Prisma set ontspiegeld met metalen randen

- Uitbreidingsset met 36 prisma glazen in de sterktes 0,50 pdpt. tot 10,00 pdpt. 0,50 pdpt. (4 stuks) 1,00 pdpt. tot 6,00 pdpt. (4 stuks) per 1,00 8,00 pdpt. tot 10,00 pdpt. (4 stuks) per 2,00
- In vier verschillende basisrichtingen (45°/135°/225°/315°)
- Geschikt voor standaard pasbrillen met 38 mm glazen

4369 13  24,5 x 9,5 x 17,5 cm  1,4 kg



Prisma set met kunststof randen

- Uitbreidingsset met 36 prisma glazen in de sterktes 0,50 pdpt. tot 10,00 pdpt. 0,50 pdpt. (4 stuks) 1,00 pdpt. tot 6,00 pdpt. (4 stuks) per 1,00 8,00 pdpt. tot 10,00 pdpt. (4 stuks) per 2,00
- In vier verschillende basisrichtingen (45°/135°/225°/315°)
- Geschikt voor standaard pasbrillen met 38 mm glazen

4369 23  24,5 x 9,5 x 17,5 cm  1,2 kg



Alles in één oogopslag.

Bewezen kwaliteit uit Duitsland, erg handig en licht.

 OCULUS

Kruiscilinder

Ontspiegeld

∅ 25 mm  12 g

4367 . .

4367 20 ± 0,25 dpt.

4367 40 ± 0,50 dpt.



Kruiscilinder

∅ 35 mm  25 g

437 . .

4370 25 ± 0,25 dpt.

4370 50 ± 0,50 dpt.

4370 75 ± 0,75 dpt.

4371 00 ± 1,00 dpt.



Balansliniaal

Ontspiegeld

Werking in dioptrieën: Sferisch ± 0,25 tot ± 0,50 dpt.

4366 05 ∅ elk 19 mm  40 g

 OCULUS



Balansliniaal

Werking in dioptrieën: Sferisch ± 0,25 tot ± 0,50 dpt.

Levering in B&S design box

4373 00 ∅ elk 21 mm  40 g



Balansliniaal assortiment

4 houten balanslinialen in houten kist.

Werking in dioptrieën: Sferisch ± 0,5 tot ± 3,5 en ± 4,0 tot ± 12,0 dpt.

4373 50 ∅ elk 21 mm  50 g/liniaal



Duotest voor het sferisch uitrefractioneren

Werking in dioptrieën: Sferisch $\pm 0,25$ dpt.

4372 00  elk 35 mm  25 g



Duotest metaal

Werking in dioptrieën: Sferisch $\pm 0,25$ dpt.
Totale PD regelbaar van 46 tot 82 mm

4374 00  elk 35 mm  72 g



Binoculaire voorhanger kunststof

Totale PD regelbaar van 44 tot 81 mm

4377 . .  elk 35 mm  37 g



4377 25 Werking in dioptrieën: Sferisch $\pm 0,25$ dpt.

4377 50 Werking in dioptrieën: Sferisch. $\pm 0,50$ dpt.



Occluder

Voor afdektest.
Totale lengte: 24,5 cm

4375 00  6 cm  21 g



Gat occluder

Om verticale en laterale geassocieerde heteroforie te meten,
voor zowel dichtbij- als afstandszicht.
Totale lengte: 24,5 cm

4375 01  6 cm  21 g



LANG fixatiekubus

Te gebruiken voor de cover- en motiliteitstest.

4378 00



Ishihara kleurkaart

In boekvorm, 14 kaarten.
Formaat: DIN A5



4476 10  250 g



Matsubara kleurkaart voor kinderen

In boekvorm, 10 kaarten, incl. 6 bijpassende kaarten.
Formaat: DIN A5



4476 20  275 g





TIPS & TRICKS

PRISMAFOLIËN CORRECT AANBRENGEN

*De juiste basispositie bepalen!***Prismafoliën**

Bestelnr. 0639 .. of 0640 ..

Universele schaar

Bestelnr. 1607 10

Foliestift

Bestelnr. 2628 01



ca. 2-3 minuten

Zo werkt het**1 UITPAKKEN****2 BEPALEN VAN DE BASIS****3 AANBRENGEN****4 MARKERING****5 UITSNIJDEN****6 BEVOCHTIGEN****7 AANBRENGEN****8 GLADSTRIJKEN****TIP:** De folie enkel met water reinigen. Om transparantieverlies te voorkomen, géén agressieve reinigingsmiddelen gebruiken!**OPMERKING:** Bewaartijd voor alle foliën max. 1 jaar. Foliën mogen alleen met een was- of vette stift gemerkt worden. Reinigingsaanbevelingen volgen a.u.b.

Prismafoliën van 3M

- Prismatische addities voor het behandelen van strabismen
- Zeer transparant materiaal met een perfecte optische kwaliteit
- Zeer flexibel, goede hechting en beeldkwaliteit
- Bruikbare diameter: 66 mm

0639 . .

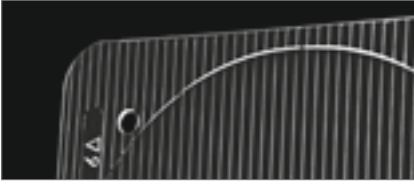

Bestelnr.	cm/m	Bestelnr.	cm/m	Bestelnr.	cm/m
0639 01	1	0639 07	7	0639 20	20
0639 02	2	0639 08	8	0639 25	25
0639 03	3	0639 09	9	0639 30	30
0639 04	4	0639 10	10	0639 35	35
0639 05	5	0639 12	12	0639 40	40
0639 06	6	0639 15	15		

Prismafoliën

- Prismatische addities voor het behandelen van strabismen
- Bruikbare diameter: 58 mm

0640 . .

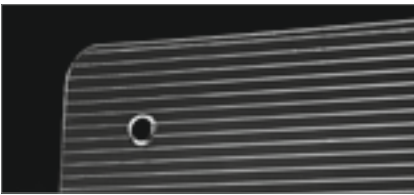

Bestelnr.	cm/m	Bestelnr.	cm/m	Bestelnr.	cm/m
0640 01	1	0640 07	7	0640 17	17,5
0640 02	2	0640 08	8	0640 20	20
0640 03	3	0640 09	9	0640 25	25
0640 04	4	0640 10	10	0640 30	30
0640 05	5	0640 12	12	0640 35	35
0640 06	6	0640 15	15		

Lensfoliën van 3M

- Sferische addities
- Zeer transparant materiaal met een perfecte optische kwaliteit
- Bruikbare diameter: 66 mm
- Middendikte: 0,8 mm

0646 . .

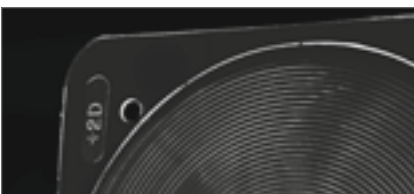

Bestelnr.	Werking dpt.	Bestelnr.	Werking dpt.
0646 10	+ 1,0	0646 25	+ 2,5
0646 15	+ 1,5	0646 30	+ 3,0
0646 20	+ 2,0	0646 35	+ 3,5



Leesdelen



Veelzijdig toe te passen ...





... in veiligheidsbrillen



... in zonnebrillen

Hydrotac

- Flexibel plastic
- Werkt d.m.v. kleeftkracht
- Gemakkelijk toepasbaar

 31 x 17 mm  1 paar

0638 ..

0638 12 + 1,25

0638 15 + 1,50

0638 17 + 1,75

0638 20 + 2,00

0638 25 + 2,50

0638 30 + 3,00



Hydrotac assortiment

- 12 verpakkingen met leesdelen
- 2 verpakkingen per dpt.



 12 paar

0638 99



3M

- Flexibel plastic
- Werkt d.m.v. kleeftkracht
- Gemakkelijk toepasbaar

 28 x 16 mm  1 paar

0637 ..

0637 10 + 1,00

0637 15 + 1,50

0637 20 + 2,00

0637 25 + 2,50

0637 30 + 3,00

0637 40 + 4,00



Oogdop

- Huidvriendelijk, zeer elastische kunststof
- Gemakkelijk aan te passen, goede ontluchting
- Sterke kleine zuignap

4439 80

 75 x 50 mm

 van de zuiger 15 mm

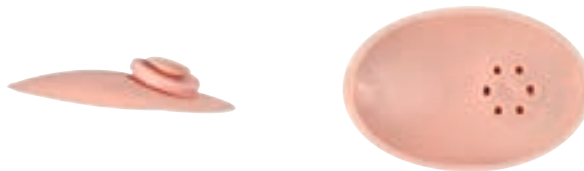

Oogdop

- Als Nr. 4439 80, maar kleine uitvoering

4439 90

 35 x 35 mm

 van de zuiger 15 mm

 3 stuks



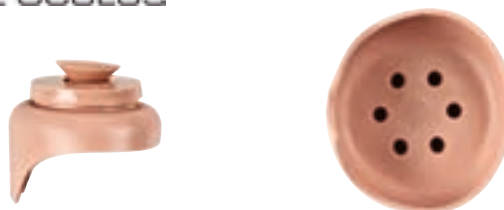



Oogdop

- Als Nr. 4439 80, maar kleine platte uitvoering

4439 95

 55 x 45 mm

 van de zuiger 15 mm

 3 stuks

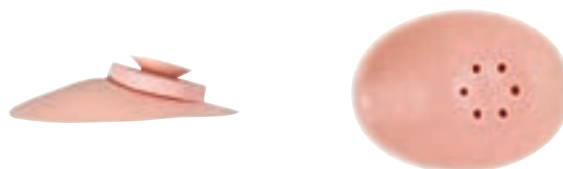

Bescherming tegen optische straling en lichte mechanische invloeden

- Siliconen, knipbaar voor metalenen kunststof brillen
- Montage in de groef

 1 paar

1316 00 **zwart**

1316 10 **half-transparant**



Occlusiefoliën in verschillende uitvoeringen

Volgens prof. Bangerter resp. Prof Lang. Met geleidelijk afnemende doorkijk voor het verminderen van de visus. Bij alternerende, volledige of aanvangende occlusie de voorschriften van de oogarts volgen.

Foliën op vellenformaat

Uit 1 folie kunnen 10 enkele foliën geknipt worden om 10 kinderbrillen te voorzien. De foliën kunnen met een schaar geknipt worden. Er kunnen ook grotere gedeelten bij bijzondere toepassingen afgedekt worden

0658 ..  215 x 105 mm

Bestelnr.	Folie	Visus-reductie	Bestelnr.	Folie	Visus-reductie
0658 20	Met motieven	Totaal	0658 01	Kleurloos	0,1
0658 00	Beige	Totaal	0658 02	Kleurloos	0,2
0658 10	Grijs	Totaal	0658 03	Kleurloos	0,3
0658 30	Mat zwart	Totaal	0658 04	Kleurloos	0,4
0658 09	Doorschijnend	Lichtperceptie	0658 06	Kleurloos	0,6
0658 07	Kleurloos	< 0,1	0658 08	Kleurloos	0,8



Enkele folie

0659 ..  60 x 60 mm

Bestelnr.	Visus-reductie	Bestelnr.	Visus-reductie
0659 00	Totaal	0659 03	0,3
0659 09	Lichtperceptie	0659 04	0,4
0659 07	< 0,1	0659 06	0,6
0659 01	0,1	0659 08	0,8
0659 02	0,2	0659 10	1,0



Enkele folie met grappige motieven voor de behandeling van scheelzien bij kinderen

Visusreductie: Totaal

0659 ..  215 x 105 mm

Bestelnr.	Motief	Bestelnr.	Motief
0659 20	Lieveheersbeestje	0659 24	Clown
0659 22	Globi met fiets	0659 25	Vlinder



KAANS Patch®

Zachte oogkap

Voor kinderen van 1–6 jaar.

- Plakt niet, geen huidirritatie
- **100% bio-wol**
- Eenvoudige montage aan elke bril
- Perfecte pasvorm en zachte afsluiting van het oog
- Wasbaar



KAAN

0650 . .

- 00 Dino



- 05 Piraat



- 10 Kat en hond



- 01 Graafmachine



- 06 Voetbal



- 11 Ster



- 02 Auto



- 07 Hart



- 12 Lieveheersbeestje



- 03 Doodskop



- 08 Bloem



- 13 Uil



- 04 Ruimteschip



- 09 Paard



Veiligheidsbrillen assortiment

– voor kinderen

- Aanbevolen voor bijv.: vuurwerk, scheikundeles, actiespellen, bijv. Nerf
- Het assortiment bestaat uit de volgende kleuren: blauw, rood, geel en roze
- Materiaal: polycarbonaat



128 mm



38 mm



12 mm



120 mm



18 g

9625 50  12 stuks (elk 3 per kleur)



Rood



Blauw



Roze



Geel

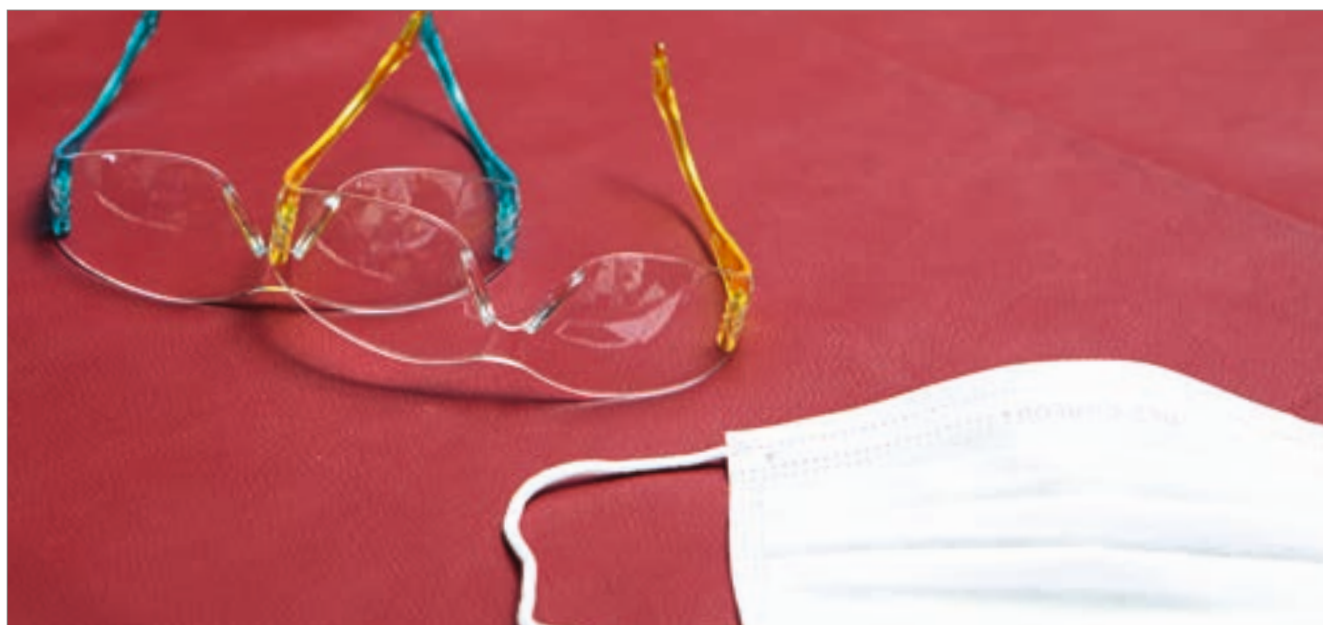

12 contactlenzenhouders „Funny Animals”

– inclusief presentatiedisplay

- Presentatiedisplay, maten (B x D x H): 211 x 147 x 30 mm

7205 00  12 contactlenzenhouders inclusief presentatiedisplay

Alle diermotieven kunnen apart besteld worden.

- 7205 01 Kikker, groen
- 7205 02 Varken, roze
- 7205 03 Nijlpaard, grijs
- 7205 04 Beer, blauw
- 7205 05 Vis, lila
- 7205 06 Olifant, geel
- 7205 07 Aap, donkerblauw
- 7205 08 Uil, donkerpaars

 8 stuks per kleur



Standaard contactlenzenhouders

- Voor zachte en vormvaste contactlenzen
- Gesorteerd op kleur (6x Blauw-wit, 6x Groen-wit)

7250 00  12 stuks



- Voor vormvaste contactlenzen
- Gesorteerd op kleur (3x Blauw-geel, 3x Blauw-oranje)

7252 00  6 stuks



- Met in het materiaal verwerkte Microban® technologie
- Blijvende bescherming tegen schadelijke microben
- Kleurassortiment (6x Blauw-wit, 6x Groen-wit)
- Voor zachte en vormvaste contactlenzen

7256 00  12 stuks



- Luchtdicht sluitende houder met 2 korfjes voor zachte contactlenzen
- Gesorteerd op kleur (3x Blauw-oranje, 3x Oranje-blauw)

7251 00  6 stuks



Contactlenzepincetten

- Klein en handig, ook voor onderweg
- Met siliconen punten, bijzonder geschikt voor zachte contactlenzen
- Op kleur gesorteerd (4 x Groen, 4 x Blauw, 4 x Wit)

7254 00  12 stuks



- Grote uitvoering, voor optimaal gebruik
- Met siliconen punten, bijzonder geschikt voor zachte contactlenzen
- Op kleur gesorteerd (4 x Geel, 4 x Donkerblauw, 4 x Donkergroen)

7254 10  12 stuks



Contactlenszuiger

- Anti-allergische siliconen, neutraal in gebruik met alle handelsgebruikelijke schoonmaak middelen
- Incl. stabiele verpakking, ook zeer geschikt voor onderweg
- Voor harde lenzen

7255 00  12 stuks

Oranje



7255 10  12 stuks

Groen



Hol, voor zachte
contactlenzen

Contactlensvanger

- Siliconen
- Beschermt uw contactlens tegen verliezen in de wastafel
- Maten: 10,7 x 13,7 cm

7257 00  3 stuks



THERA°PEARL® Eye-ssential™ Oogmasker

- Past zich aan uw gezicht aan, voor een weldadige verlichting tegen: droge ogen, hoofd- en bijholtepijn en opgezette ogen en meer

THERA°PEARL®
A NEW DEGREE OF RELIEF™

7293 00

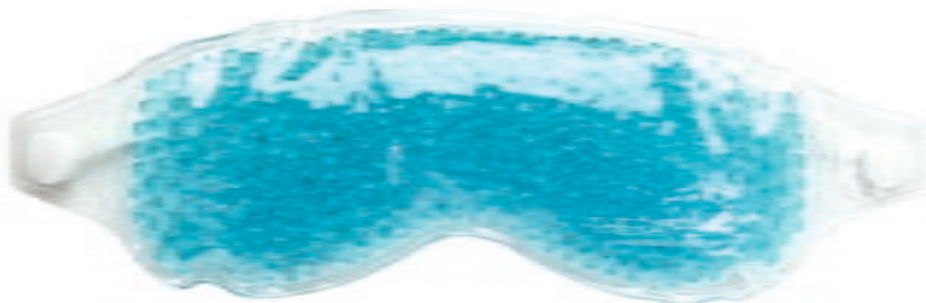



Sferometer met saffier „Made in Germany“.

Een essentieel instrument en kwaliteitsproduct „Made in Germany“. De uiterst duurzame precisie sferometer wordt met handwerk in een stootvast metalen behuizing geplaatst en levert altijd correcte meetgegevens op.

Sferometer

- Voor alle sferische en astigmatische lenzen met **brekingsindex n 1,52 en n 1,70**
- Voelers met saffierkogels bezet, om het glas tijdens de metingen niet te beschadigen
- Meetbereik: 0 tot ± 20 dpt.
- Levering in kartonnen doos

2315 02  80 g



Sferometer

- Voor alle sferische en astigmatische lenzen met **brekingsindex n 1,53**
- Meetbereik: 0 tot ± 20 dpt.
- Levering in B & S design box

2315 10  62 g



Sferometer

- Voor alle sferische en astigmatische lenzen met **brekingsindex n 1,49 en n 1,60**
- Meetbereik: 0 tot ± 18 dpt.
- Levering in B & S design box

2315 20  62 g



Met saffier uitgeruste kogellagers, extra lange diktevoelers „Made in Germany”.

Met dit product kun je perfect de dikte meten, zelfs van zeer hoge minus lenzen. De 0-positie is verstelbaar.

Diktemeter

- Met lange voelers
- Kogelvormige spitsen gemaakt van saffier
- 0-positionering is instelbaar
- Inclusief box en stelsleutel
- Voelerlengte: 80 mm
- Lensdikte: tot 20 mm
- Aflezen: 0,05 mm
- Levering in neopreentasj

2317 00  350 g



Diktemeter

- Met lange voelers, spitsen kogelvormig
- Voelerlengte: 75 mm
- Lensdikte: tot 20 mm
- Aflezen: 0,05 mm
- Levering in kunststof box

2314 00  390 g



Diktemeter

- Voelerlengte: 45 mm
- Lensdikte: tot 10 mm
- Aflezen: 0,05 mm
- Levering in kunststof box

2318 00  75 g



Digitale schuifmaat

Elektronisch aangegeven meetwaarden in „mm“ of „inch“ instelbaar.
 Meetwaarden: 0,1 mm = 0,004 inch
 Batterij: knoopcel 1,5 V
 Meetbereik: 150 mm
 Bekdiepte: 40 mm

2335 00  315 g



Universele schuifmaat

Roestvrij, matverchromd.
 Meetwaarden: 1/50 mm en 1/1.000 inches
 Meetbereik: 150 mm
 Bekdiepte: 40 mm

2337 02  170 g



Pocketschuifmaat

Van hoogwaardig messing met
 6 verschillende meetmogelijkheden
 Lengte: 100 mm
 Bekdiepte: 40 mm

2333 10  65 g







Precisiewerk

De B & S markeerfolie biedt door zijn centrische opdruk van de markering een hoge nauwkeurigheid. Als extra wordt door contrastrijk inkt het aflezen van de waardes gemakkelijker. De continue kwaliteit van de bedrukking wordt door de duitse producenten gegarandeerd.

B & S markeerfolie

Met gestanst machinedraaipunt, hulplijnen voor het tekenen van pupilcentrum en leesdeelhoogte, makkelijke bewerking.
 Passend voor Rodenstock en Essilor systeem.



2359 02  68 x 0,5 x 68 mm  200 stuks

2359 04  68 x 0,5 x 68 mm  50 stuks



Leesdeelhoogtemeter

Transparant, schaalverdeling witgedrukt.

2371 02  75 x 37 mm  2 stuks



Een zeer speciale werkplek:

De magnetische werking van het oppervlak houdt schroeven en moeren vast. (verkleint de kans op wegspringen van vallende kleine onderdelen). De aluminium rand voorkomt het wegglijden en vereenvoudigt de montage en de afstelling van brillen. Hulplijnen voor het compleet uitrichten van alle monturen.

Werkblad volgens Mütz

Werkblad voor in de werkplaats.

Ideaal voor het uitrichten van alle monturen, vooral tijdens demontage van glasbrillen.

- De magnetische werking houdt schroeven en moeren vast (verkleint de kans op wegspringen van vallende kleine onderdelen)
- Meetlijnsysteem voor het bepalen van de **inclinatiehoek** van zonne- en sportbrillen met extreme glascurve
- Hulplijnen voor het uitrichten van alle monturen
- Centreerhulp voor het bepalen van het montuurmidden
- Aluminium randen voorkomen wegglijden en fungeren als steun bij het schroeven
- Meetlijnen voor veerinclinatie
- Liniaal
- Sjabloon voor het bepalen van de glasdiameter
- Contraststrepen ter markeringscontrole

2365 21

39,4 x 28 cm

800 g

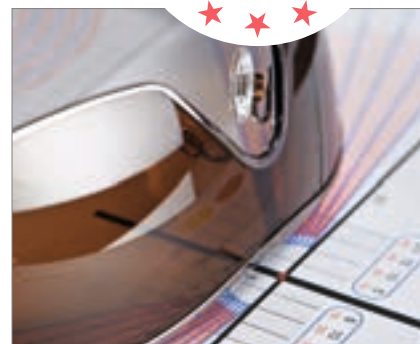



TIPS & TRICKS

THE CUBE

Drie in één

The Cube
Bestelnr. 2372 50



ca. 1 minuut

Zo werkt het



OPTIE 1:

1 INZETTEN



2 AANTEKENEN



3 CONTROLE



4 CORRECTIE



OPTIE 2:

1 METEN



OPTIE 3:

1 METEN



Markeerhulp „The Cube”

Deze markeerhulp werd ontwikkeld om 3 handelingen in 1 te combineren: Het eenvoudig en snel markeren van brillenglazen, het meten van inklinatie en het controleren van centreerhoogtes.

De Staedler stif (incl. hoeft alleen nog in de conische opening in het midden geplaatst te worden en u kunt beginnen.

Afhankelijk van op welke kant het blok staat, kan een hulplijn in vier verschillende hoogtes vliegensvlug en parallel getekend worden. Met de ingegraveerde liniaal op één van de zijden van het blok kan de leesdeelhoogte van een bifocaalglas, de progressiehoogte van een progressiefglas of elke andere hoogte gemeten worden.

Bovendien biedt „The Cube” 2 schalen voor inklinatiemeting. Vanzelfsprekend kan hiermee zowel de rechter- als de linkerveer gemeten worden.



The Cube

- Eenvoudig en snel markeren van brillenglazen
- Inklinatiemeting en controle van leesdeelhoogte
- Inclusief Staedler stif (Bestelnr. 2627 01)

2372 50

55 x 55 x 30 mm



Glaslineaal basiscurve 4 en basiscurve 6

Voor het strepen aan de achterzijde van het glas.
Verbeterd de gebruikelijke lijn vanwege het aanpassen van de liniaal aan de achterzijde van het glas.

2372 00  70 x 36 mm



Fine Line Ruler

Voor het controleren van de as van ongeslepen en geslepen enkelvoudige en meervoudige glazen.

2367 00  130 x 18 x 85 mm



Polarisatiefilter test

Voor het controleren van de as bij ongeslepen en geslepen polariserende glazen.

2379 00  120 x 1 x 50 mm



Taboschema

Volgens DIN 58201, aluminium, schaalverdeling geëts. Aan de achterkant formules voor prismawerking bij gedecentreerde brillenglazen.

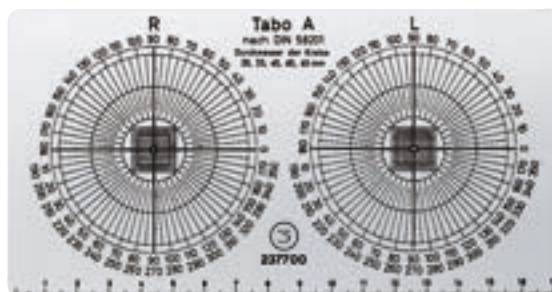

Meetbereik: 0–170 mm

2377 00  175 x 1 x 90 mm



Malplaatje

Kunststof, met schaalverdeling aan de ene kant en dradenkruis aan de andere kant, met papierschuur te knippen.

2395 30  71 x 1,5 x 65 mm  100 stuks

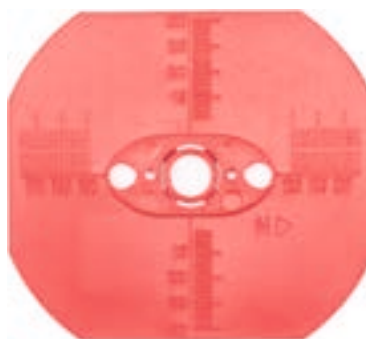



PD maat transparant

Polycarbonaat.

Met openingen voor het bepalen van de draaddiameter.

Meetbereik: 0–160 mm (mm indeling)

2373 00  205 mm  3 stuks



PD maat

PVC.

Met centreervoorziening aan de achterkant voor bruggen en neussteunen.

Vereenvoudigd het precieze aflezen van de markeringen.

Meetbereik: 0–140 mm (mm indeling)

2325 00  165 mm  2 stuks



Ada-meter

Volgens Bremer, kunststof, voor metingen van de PD, enkele PD, leesdeelhoogte, neusbreedte en inclinatiehoek.

Meetbereik: 0–145 mm (mm indeling)

2376 00  155 mm



PD maat

Kunststof.

Meetbereik: 0–170 mm (mm indeling)

2374 00  180 mm



Liniaal metaal

Buigzaam, schaalverdeling geëts.

Meetbereik: 0–150 mm (mm indeling)

2320 01  165 mm



Gradenboog 180°

Metaal.

Hoek bereik: 0–180°

2366 00  45 x 174 mm





3M LEAP™ III Pad
3M LEAP™ III Pad
3M LEAP™ III Pad
3M LEAP™ III Pad
3M LEAP™ III Pad
3M LEAP™ III Pad
3M LEAP™ III Pad
3M LEAP™ III Pad
3M LEAP™ III Pad
3M LEAP™ III Pad

UV Fix Gel
3184 02
B&S

Allgemeine
Schmucklot
600 Ag L3

GERMANY





VERBRUIKSARTIKELEN

voor eerste hulp maatregelen



- E 2 Afnameblokken en glasplakkers
- E 8 Bescherm- en anti-torsiefolien
- E 9 Slijpwater toevoeging en reinigungssteen
- E 10 Markeerstiften
- E 11 UV gel
- E 12 Lijmen en borgmiddelen
- E 17 Oliën en reinigers
- E 20 Kleurpoeder
- E 21 Desinfectiedoeken
- E 22 Tips & tricks: Plasti Dip
- E 24 Reparatieverven en stiften
- E 27 Tips & tricks: polijsten
- E 28 Schijven en borstels
- E 30 Glans-, polijst- en slijppasta's en was
- E 32 Slijp- en schuurmiddelen
- E 34 Soldeer en vloeimiddelen



- 1 **Afnameblokken**
- 2 **Glasplakkers**
- 3 **Anti-torsie folie**
- 4 **Beschermfoliën
(achterkant van de lens)**

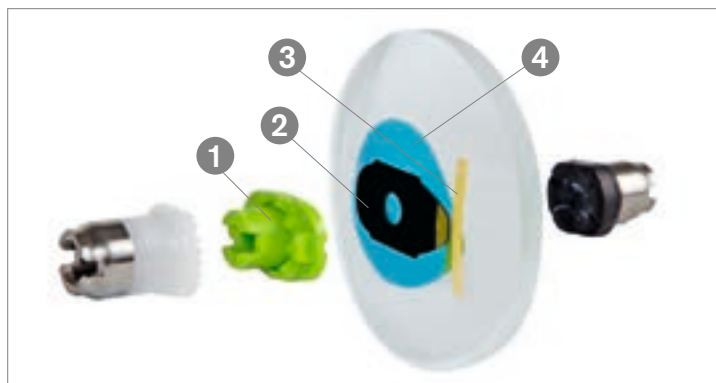

NIDEK afnameblok Pliable-Cup

Flexibel afnameblok voor NIDEK machines met originele NIDEK afname.
Door de lange vorm wordt het gevaar van asverdraaiing verminderd.

Alleen met de passende B & S plakpads Nr. 2502 17, 2503 17, 2506 17, 2507 17, 2508 17, 2510 17, 2511 17 of 2512 17 gebruiken!

Tot curve 8.

∅ 30 x 17 mm  10 stuks



3710 17N



3710 17R
Rood (linker glas)



3710 17G
Groen (rechter glas)



3710 50
Kleurgesorteerd (5x rood en
5x groen) voor links rechts
onderscheid

Voor hoge curves **vanaf basis 8**.

∅ 30 x 17 mm  10 stuks



3711 17

NIDEK afnameblok Mini-Cup

Flexibel afnameblok voor NIDEK machines met originele NIDEK afname. Afnameblok voor kleine tot zeer kleine glas- en montuurvormen.

Tot curve 6.

∅ 20 x 15 mm  10 stuks



3714 15



3714 15R
Rood (linker glas)



3714 15G
Groen (rechter glas)



3714 50
Kleurgesorteerd (5x rood en
5x groen) voor links rechts
onderscheid

NIDEK afnameblok Nano-Cup

Flexibel afnameblok voor NIDEK machine LEX 1000 met originele NIDEK afname.
Speciaal afnameblok voor zeer kleine glas- en montuurvormen. Gebruik compleet met buitenring.
Alleen met de passende B & S plakpad Nr. 2503 13 gebruiken!

Tot curve 6.

∅ 30 x 17 mm/18 x 13,5 mm

10 stuks



3715 13R
Rood (linker glas)



3715 13G
Groen (rechter glas)



3715 13
Kleurgesorteerd (5x rood en
5x groen) voor links rechts
onderscheid



Varioblok

Flexibele kunststof, voor plakker. Passend voor WECO afname.

∅ 25 x 20 mm

∅ 25 mm

∅ 25 x 20 mm

∅ 25 mm

10 stuks

25 stuks

10 stuks

25 stuks



3700 20
Wit
Platte curve

3700 25
Wit
Platte curve

3701 20
Rood
Voor sterke plusglazen

3701 25
Rood
Voor sterke plusglazen



De plakpads moeten naar gelang het materiaal niet langer dan een half tot één jaar bewaard worden. Bewaring bij kamertemperatuur (ca. + 18 °C) en ca. 30 % relatieve vochtigheid. Voor een optimale hechtcracht de pads in de koelkast bewaren en ca. 15 min. voor gebruik er uitnemen.



Plakpads voor superhydrofobe glazen

- Materiaal: Ethylvinylacetaat- schuim
- Geïntegreerde anti-torsiefolie
- Levering in dispenserdoos

0,9 mm 1 rol (500 stuks)



2511 17



2511 19



2511 22



2511 24

Bestelnr.	Ø in mm	Hechtcracht	axiale torsie	Type	voor afnameblokken
2511 17	31 x 17			NIDEK	Nr. 3710 .. 3711 17
2511 19	30 x 18	zeer hoog voor superhydrofobe glazen	zeer hoog, inclusief anti-torsiefolie	Universeel	
2511 22	22			Universeel	
2511 24	24			Universeel	

- Materiaal: Ethylvinylacetaat- schuim
- Geïntegreerde anti-torsiefolie
- Levering in dispenserdoos

0,9 mm 1 rol (500 stuks)



2510 17



2510 18



2510 24



Bestelnr.	Ø in mm	Hechtcracht	axiale torsie	Type	voor afnameblokken
2510 17	31 x 17			NIDEK	Nr. 3710 .. 3711 17
2510 18	30 x 18	hoog voor superhydrofobe glazen	hoog, inclusief anti-torsiefolie	Universeel	
2510 24	24			Universeel	

Plakpads voor hydrofobe glazen

- Materiaal: Polyurethaan-schuim
- Levering in dispenserdoos

± 0,9 mm  zie tabel



2507 14



2507 17
2507 171



2507 18
2507 181



2507 22
2507 221



2507 24
2507 241

Bestelnr.	Ø in mm	Hechtkracht	axiale torsie	Type	voor afnameblokken	 (stuks)
2507 14	21 x 14			Universeel		1 rol (500)
2507 17	31 x 17			NIDEK	Nr. 3710 .. 3711 17	1 rol (500)
2507 171	31 x 17			NIDEK	Nr. 3710 .. 3711 17	1 rol (1.000)
2507 18	30 x 18			Universeel		1 rol (500)
2507 181	30 x 18	zeer hoog voor hydrofobe glazen	zeer hoog	Universeel		1 rol (1.000)
2507 22	22			Universeel		1 rol (500)
2507 221	22			Universeel		1 rol (1.000)
2507 24	24			Universeel		1 rol (500)
2507 241	24			Universeel		1 rol (1.000)

- Materiaal: Polyurethaan-schuim
- Levering in dispenserdoos

± 0,9 mm  1 rol (1.000 stuks)



2512 17



2512 19



2512 22



2512 24

Bestelnr.	Ø in mm	Hechtkracht	axiale torsie	Type	voor afnameblokken
2512 17	31 x 17			NIDEK	Nr. 3710 .. 3711 17
2512 19	30 x 19,5	zeer hoog voor hydrofobe glazen	zeer hoog	Universeel	
2512 22	22			Universeel	
2512 24	24			Universeel	



Plakpads voor hydrofobe glazen

- Materiaal: Polyurethaan-schuim
- Levering in hersluitbare plastic zak

 0,9 mm

 10 stroken (200 stuks)

2508 17



2508 18



2508 24

Bestelnr.	Ø in mm	Hechtkracht	axiale torsie	Type	voor afnameblokken
2508 17	31 x 17	hoog voor hydrofobe glazen	hoog	NIDEK	Nr. 3710 .. 3711 17
2508 18	18			Universeel	
2508 24	24			Universeel	

Plakpads voor standaard glazen

- Materiaal: PVC film
- Vergelijkbaar met 411 e kwaliteit (dun maar zeer sterk materiaal)
- Levering in dispenserdoos

 0,38 mm

 zie tabel

2502 17



2502 18



2502 19



2502 21



2502 24

Bestelnr.	Ø in mm	Hechtkracht	axiale torsie	Type	voor afnameblokken	 (stuks)
2502 17	32 x 17	hoog voor standaard glaze	hoog	NIDEK	Nr. 3710 .. 3711 17	1 rol (1.000)
2502 18	18			Universeel		1 rol (1.000)
2502 19	28 x 18			Universeel		1 rol (500)
2502 21	30 x 21			Universeel		1 rol (500)
2502 24	24			Universeel		1 rol (1.000)

Plakpads voor standaard glazen



- Materiaal: Ethylvinylacetaat- schuim
- 3M Leap III Plakpads – het origineel van 3M met dubbele lip
- Levering in dispenserdoos
- Levering in hersluitbare plastic zak (2503 13)

 0,8 mm  zie tabel



Bestelnr.	Ø in mm	Hechtkracht	axiale torsie	Type	voor afnameblokken	 (stuks)
2503 13	31 x 17 18 x 13,5			NIDEK Nano-Cup	Nr. 3715 13 (tweedelig)	5 stroken (100)
2503 17	31 x 17	zeer hoog voor standaard glazen	zeer hoog	NIDEK	Nr. 3710 .. 3711 17	1 rol (1.000)
2503 18	18			Universeel		1 rol (1.000)
2503 26	26			Universeel		1 rol (1.000)

- Materiaal: Polyolefin-schuim (2501 . .), Polyethyleen-schuim
- Levering in dispenserdoos

 0,9 mm (2501 18)  0,8 mm  1 rol (1.000 stuks)



Bestelnr.	Ø in mm	Hechtkracht	axiale torsie	Type	voor afnameblokken
2506 17	31 x 17			NIDEK	Nr. 3710 .. 3711 17
2501 18	18			Universeel	
2501 24	24			Universeel	
2500 19	30 x 18	hoog voor standaard glazen	hoog	Universeel	
2500 22	22			Universeel	
2500 24	24			Universeel	



Bescherm- en anti-torsiefoliën

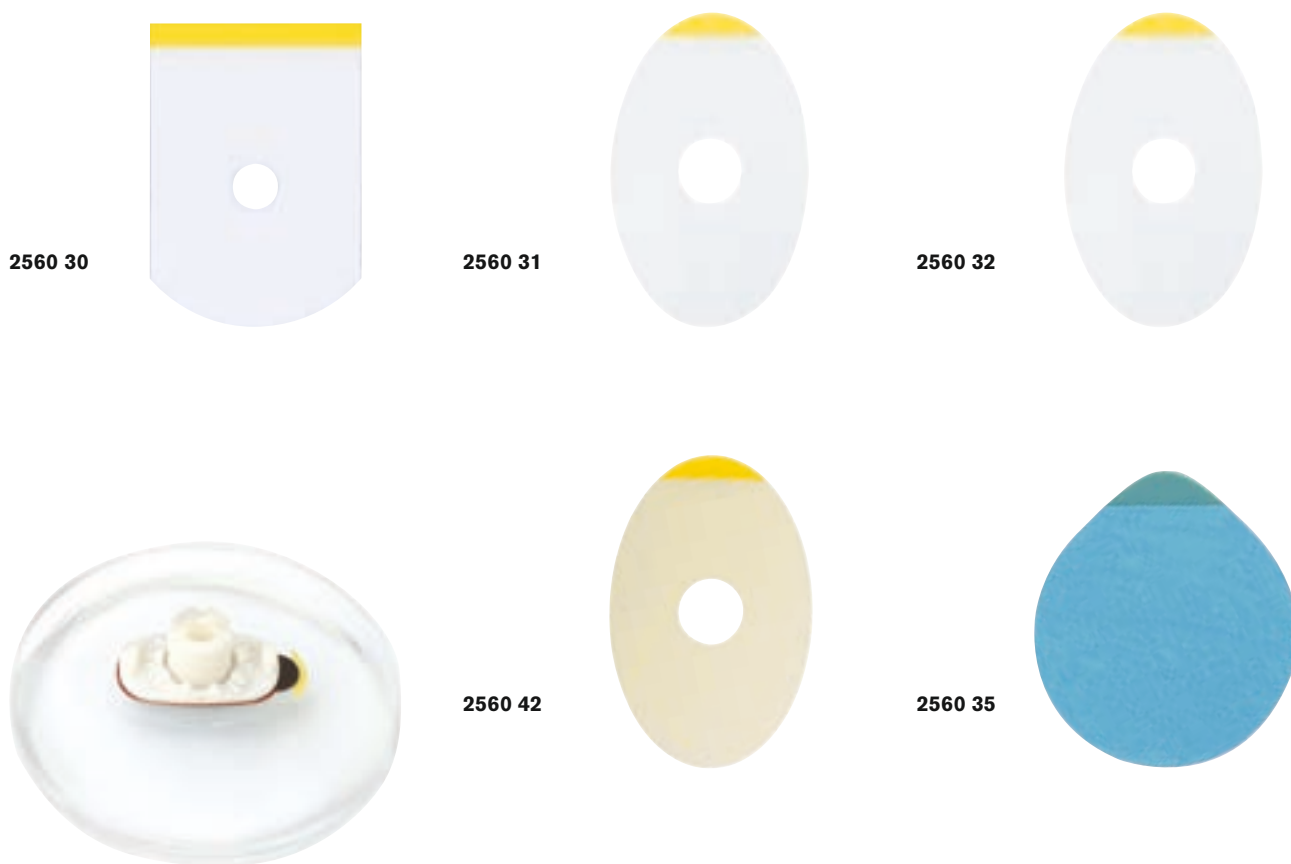

Bestelnr.	Ø in mm	Productinformatie	Inzetbaar voor	📦 (stukks)
Anti-torsiefolie				
2560 30	40 x 28	Ter bescherming van de voor- en achterzijde van het glasoppervlak tijdens het slijpen. De beschermfolie is speciaal geschikt voor hoogwaardig gecoate glazen. De plakfolie is 6 maanden te bewaren.	Bij glazen met + 4,5 dpt. aan de voorkant.	1 rol (500)
2560 31	40 x 28	Ter bescherming van de voor- en achterzijde van het glasoppervlak tijdens het slijpen. De beschermfolie is speciaal geschikt voor hoogwaardig gecoate glazen. De plakfolie is 6 maanden te bewaren.	Bij glazen met + 4,5 dpt. aan de voorkant. Ovale vorm voor een betere hantering!	1 rol (500)
2560 32	40 x 26	Voor hoge glascurves. Ter bescherming van de voor- en achterzijde van het glasoppervlak tijdens het slijpen. De beschermfolie is speciaal geschikt voor hoogwaardig gecoate glazen. De plakfolie is 6 maanden te bewaren.	Bij glazen met hoge basiscurven. Bijzonder flexibel!	1 rol (500)
2560 42	40 x 26	Ter bescherming van de voor- en achterzijde van het glasoppervlak tijdens het slijpen. De verbeterde lijm verhoogt de kleefkracht op alle hydrofobe glazen. De plakfolie is 6 maanden te bewaren.	Bij glazen met + 4,5 dpt. aan de voorkant en hydrofobe glazen. Ovale vorm voor een betere hantering!	1 rol (500)
Glas bescherming				
2560 35	35	Ter bescherming van de achterzijde van het glasoppervlak tijdens het slijpen.		1 rol (1.000)

Lens Grip

- Lijmspray voor hydrofobe en Cleancoat coatings
- Werkt tevens als beschermfolie tegen krassen en kan aan de voor- en achterkant gebruikt worden
- Voorkomt asverdraaiing bij het slijpen en onnodige glasbreuk door het verschuiven van de glazen
- Eenvoudig te verwijderen met bestaande reinigingsmiddelen
- Droogt snel en is spaarzaam in gebruik

2562 00 📦 150 ml 📏 144 x 50 mm

2562 10 📦 500 ml 📏 238 x 63 mm



Milieuvriendelijke anti-schuimvorming vloeistof

Deze slijpmiddeltoevoeging uit Japan heeft door zijn 100 % ecologische samenstelling, hoog rendement en efficiëntie het B & S predikaat Top Product verdiend. Het product is overtuigend na het eerste gebruik en maakt een eind aan de lastige schuimvorming tijdens het slijpen. Een eveneens positief effect is de verminderde corrosie aan machineonderdelen. Speciaal aanbevolen door het „B&S goes Green” team.

Slijpmiddeltoevoeging, blauw

- Voorkomt schuimvorming tijdens het slijpen
- Verbetert de slijpwerking
- Koelt en beschermt machineonderdelen
- Optimaal machineonderhoud
- Vermindering van slijpsel
- Snel bezinken van vuildeeltjes
- Minimale aerosol opbouw
- Inhoudstoffen zijn ongevaarlijk, fysiologisch veilig
- Zeer zuinig (100 ml slijpmiddeltoevoeging op 20 liter water)



3148 50

 500 ml

Plastic zak voor slijpwater

Ook geschikt voor polycarbonaat.

2900 51

 800 x 560 x 0,06 mm

 10 stuks



Om chemische reacties te voorkomen adviseren wij het slijpwater tenminste elke 2 weken te vervangen.



Reinigingssteen voor handslijpstenen, groen

- Type: Fijn
- Inzetbaar voor: Diamantschijven, fijn

3419 00

 100 x 8 x 25 mm

 40 g

Reinigingssteen

- Kleur: Rood
- Type: Grof
- Korrel: 120
- Inzetbaar voor: Voorslijpschijven diamant

3422 12

 110 x 12 x 25 mm

 927 g

 12 stuks

- Kleur: Wit
- Type: Fijn
- Korrel: 320
- Inzetbaar voor: Fijnslijpschijf diamant

3423 12

 100 x 13 x 25 mm

 831 g

 12 stuks

- Kleur: Lichtblauw
- Type: Zeer fijn
- Korrel: 1.500
- Inzetbaar voor: Polijstschijschijf diamant

3424 01

 100 x 13 x 25 mm

 80 g

Grafiet drukstift

- Te gebruiken op folie, brillenglazen en gladde oppervlakken
- Wit is geschikt voor donkere materialen, in het bijzonder getinte glazen
- Navulbaar met punten Nr. 2624 22 en 2624 55

2624 02



Wit



2624 22



Wit

12 stuks

2624 05



Rood

2624 55



Rood

12 stuks

Glasmarkeerstift

- Speciaal voor glazen met Clean Coating
- Licht-, water- en veegbestendige inkt
- Droogt snel en laat zich met spiritus verwijderen
- Lijndikte : 0,8 mm
- Punt: Rond

2620 02



Wit

2 stuks



Glasmarkeerstift

- Speciaal voor glazen met Clean Coating
- Geen druppels op waterafstotende oppervlakken
- De inkt laat zich met spiritus verwijderen
- In een gepatenteerde box
- Twee soorten: Fijn en zeer fijn

2625 01



Zwart, fijn

4 stuks

2625 05



Rood, fijn

4 stuks

2627 01



Zwart, zeer fijn

4 stuks



Universele stift, fijn

- Watervast, voor duurzaam beschrijven
- Met Dry Safe functie – de stift kan uren geopend liggen zonder uit te drogen
- In een gepatenteerde box

2623 01



Zwart

4 stuks

2623 05



Rood

4 stuks



Inkt remover stift

Glasmarkeringen kunnen eenvoudig verwijderd worden door middel van deze stift. De inkt remover stift is geschikt voor **elk type lens**.

2630 00



Foliestift

Wateroplosbare, wisvaste foliestift voor oclusiefoliën, lens- en prismafoliën.

2628 01



Zwart

2 stuks



Te grote, verkeerd geboorde gaten zijn van gisteren

Voor het verdichten, reparaties of verbeteren van schoonheidsfoutjes - de UV-Gel is de onmisbare hulp van de opticiën. Doordat het UV licht uithardend werkt, kan het onder meer voor verglazing en bewerking van glasbrillen gebruikt worden en in geharde uitwerking verder verwerkt worden. De hoge sterkte, de glasheldere kleur, het niet plakkend oppervlak en de mogelijke toepassing bij Polycarbonaat, maakt dat dit product boven soortgelijke uitstijgt. Daarom waarderen we het als Top Product.

Beschikbaar als:

a) UV gel doseerspuit

- Ideaal voor zeer kleine verlijmingen
- Handelbaar, praktisch
- Geen luchtbelletjes in de canule

3184 03

 3 ml



3184 03

b) UV gel doseerflacon

- Praktische doseerflacon
- Hersluitbaar
- Met doseerpunt voor exacte dosering

3184 10

 10 ml



Toebehoren: UV gel omkeerhouder

- UV Gel is direct te druppelen en tot de laatste druppel te gebruiken
- Stabiel en ideaal voor direct gebruik
- Geen luchtbelletjes in de canule
- Doseerflacon niet bij levering inbegrepen

3184 09

 40 x 65 x 50 mm

Proformic UV lijm

- Kan in vele lagen worden aangebracht
- Uitharding door speciaal ontwikkelde en meegeleverde LED
- Kan uitgehard bewerkt worden
- Kleur na uitharding transparant tot licht gelig
- Oplosmiddelvrij
- Levering in metalen doos

3186 00

 4 g

Navul dispenser

3186 01

 4 g



Onze UV lampen Nr. 2431 00 en 2421 00 vindt u op pagina A 38.



Secondenlijm

Loctite 4850

- Secondenlijm perfect geschikt voor glasbrillen en special verdraagzaam voor **polycarbonaat en Trivex**
- Kleur: Transparant

3162 00  5 g

3162 02  20 g



Loctite 460

- Secondenlijm
- Ook geschikt voor **polycarbonaat en Trivex glazen**
- Kleur: Transparant

3162 10  20 g



VA 2500 HT

- Secondenlijm met hoge viscositeit
- Speciaal voor **polycarbonaat en Trivex glazen**
- Resistent tegen vloeistoffen
- Blijft flexibel na uitharding
- Kleur: Transparant

Vergelijkbaar met Loctite 4850

3165 00  5 g

3165 02  20 g



VA 1460

- Secondenlijm met middelhoge viscositeit
- Ook voor **polycarbonaat en Trivex glazen** geschikt
- Weinig gevoelig voor vloeistoffen
- Kleur: Transparant

Vergelijkbaar met Loctite 460

3165 10  20 g



Universele lijm

Loctite 401

- Allesklever
- Ook geschikt voor **hout**
- Niet geschikt voor polycarbonaat en Trivex glazen
- Kleur: Transparant

3162 20  5 g



Loctite 454 Gel

- Gel, vloeit en drupt niet na, vloeit niet weg op loodrechte oppervlakken
- Ondersteboven bruikbaar
- Zeer precies doseerbaar
- Enkele seconden corrigeerbaar
- Zeer geschikt voor voor het verlijmen van **strassstenen**
- Niet geschikt voor polycarbonaat en Trivex glazen

3162 30  3 g



VA 1401

- Middelhoge viscositeit
- Ook geschikt voor **hout**
- Niet geschikt voor polycarbonaat en Trivex glazen
- Snelle uitharding
- Kleur: Transparant

Vergelijkbaar met Loctite 401

3165 20  4 g



Glaslijm

Loctite glaslijm 3494

- Voor het lijmen van correctieglazen in duikbrillen geschikt
- Oplosmiddelvrij, kristalheldere ééncomponentenlijm
- Voor glas en UV doorlatende kunststoffen

3181 30  25 ml



Hypo tube cement

- Voor het inplakken van glazen in alle soorten monturen, ook als vloeibare inleg te gebruiken

3177 00  9 ml



Schroeven-grip

- Voor het verwijderen van alle soorten beschadigde schroeven
- Directe werking (zonder uitharden)
- Na gebruik enkel afvegen

3168 00  20 g



- De vulhoogte bij lijmen kan om productietechnische redenen verschillen
- De hechtwaarden hebben betrekking op het gebruik van montuurschroeven en kunnen daardoor afwijken van de opgave van de fabrikant



Universele lijmen (ook voor kunststof)

Secondenlijm

- Nieuw ontwikkeld pen-systeem ligt als een stift in de hand
- Eenvoudig in gebruik, vlekkeloze verwerking en verbeterde dosering
- Voor **kunststoffen, rubber, metaal, balsahout, leer**
- Uitharding 24 uur
- Niet geschikt voor polycarbonaat en Trivex glazen



3185 12  12 g

Oplosmiddel

- Nieuw ontwikkeld pen-systeem ligt als een stift in de hand
- Eenvoudig in gebruik, vlekkeloze verwerking en verbeterde dosering
- Oplosmiddel voor alle cyaanacrylaat lijmen
- Korte inwerktijd
- Niet geschikt voor polycarbonaat en Trivex glazen



3185 22  30 g

Secondenlijm SICO MET 40

- Snel uithardende, oplosmiddelvrije secondenlijm met zeer goede vloeieigenschap
- Ook geschikt voor **polycarbonaat**



3185 30  20 g

Seconden alles-lijm, vloeibaar

- Snelle uitharding, oplosmiddelvrij
- Veelzijdig en spaarzaam in gebruik
- Ook geschikt voor **polycarbonaat**



3183 04  4 g

VA 20

- Secondenlijm met lage viscositeit
- Snelle uitharding, oplosmiddelvrij
- Ook geschikt voor **polycarbonaat**

Vergelijkbaar met SICO MET 40



3185 40  20 g

Borgmiddellen voor schroeven

Loctite 221

- Minder vast
- Kleur: Rood

3159 00  10 ml



Loctite 243

- Zeer vast
- Kleur: Blauw

3161 00  10 ml

3161 05  50 ml



LOCK AN 302-21

- Nieuw ontwikkeld pen-systeem ligt als een stift in de hand
- Eenvoudig in gebruik, vlekkeloze verwerking en verbeterde dosering
- Minder vast
- Kleur: Rood

Vergelijkbaar met Loctite 221

3160 00  20 ml



LOCK AN 302-43

- Nieuw ontwikkeld pen-systeem ligt als een stift in de hand.
- Eenvoudig in gebruik, vlekkeloze verwerking en verbeterde dosering
- Hoge hechtkracht
- Kleur: Blauw

Vergelijkbaar met Loctite 243

3164 00  10 ml

3164 05  50 ml



Borgmiddel met gepatenteerde doseerpunt

- Minder vast
- Kleur: Blauw

3178 00  10 g



- De vulhoogte bij lijmen kan om productietechnische redenen verschillen
- De hechtwaarden hebben betrekking op het gebruik van montuurschroeven en kunnen daardoor afwijken van de opgave van de fabrikant



Mengstander voor mengnap

1406 00



Mengnap

1407 00

∅ 21 mm

6 stuks



Doseerpunten van kunststof

- Voor het precies doseren van borgmiddel
- Binnendiameter: 0,84; 0,5 en 0,41 mm

1405 10

3 stuks



Canule van kunststof

- Korte metalen punt voor het eenvoudig doseren van secondenlijmen
- Lange flexibele kunststofpunt kan bij verstopping ingekort worden
- Binnendiameter: elk 0,84 en 0,25 mm

1405 20

4 stuks



Spuitfles

- Materiaal: LDPE
- Capaciteit: 1 l

1488 03



Vloeistofdispenser

- Dispenser voor aceton, benzine, spiritus, B & S speciaalreiniger Nr. 3175 . . e.d.
- Met pompmechanisme, éénhandsbediening, geurverminderend, vervaardigd uit HDPE, stalen deksel
- Met voorgedrukte zelfklevende etiketten
- Capaciteit: 125 ml



1487 10

Vloeistofdispenser

- Dispenser voor aceton, benzine, spiritus, B & S speciaalreiniger Nr. 3175 . . e.d.
- Met pompmechanisme, éénhandsbediening, geurverminderend
- Vervaardigd uit PP met kunststof deksel
- Capaciteit: 120 ml



1489 00

3 stuks

Aceton

- Voor het kisten van acetaat monturen
- Voor het vetvrij reinigen van oppervlakken
- Voor kunststof monturen (géén optyl)

3173 00  100 ml



Speciaalreiniger voor glazen

- Reiniger voor polycarbonaat, kunststof en Trivex glazen
- Ideaal voor het verwijderen van glasmarkeringen op progressieve glazen
- Optimaal te doseren met B&S vloeistofdispenser Nr. 1487 10 en 1489 00

3175 02  250 ml

3175 10  1 l



Druppelpen

- Behuizing van massief aluminium
- Doseert druppelsgewijs olie
- Voor zuurvrije en alkalische olie te gebruiken
- Capaciteit: 5 ml

2742 00  145 mm



Olie

- Voor montuurscharnieren, hoogwaardig, zuurvrij

3171 00  20 ml



Boorolie

- Voor koeling tijdens boren

3170 00  100 ml



Luchtdrukspray

Verwijdert snel en betrouwbaar stof en pluizen van gevoelige oppervlakken en moeilijk bereikbare plaatsen.

Te gebruiken voor: Optiek, instrumenten, medische techniek, uurwerken, audio/video apparatuur en modelbouw

3174 15

 400 ml



Siliconenspray Loctite 8021

Voor onderhoud aan automaten, machines, impregneert rubber, kunststof en leer. Vuil- en waterafstotend, smeert, beschermt tegen oxydatie en corrosie.

Belangrijk!

Niet in contact laten komen met brillenglazen.

3174 10

 400 ml



Siliconen onderhoudsspray

Reinigt en beschermt automaten, machines, impregneert rubber kunststof en leer. Vuil- en waterafstotend, smeert en beschermt tegen oxydatie en corrosie.

Belangrijk!

Niet in contact laten komen met brillenglazen.

Vergelijkbaar met Loctite 8021

3174 20

 400 ml



OPTOCLEAN

Reinigingsconcentraat 1:20 voor monturen, en optische glazen (ook kunststof) voor de ultrasoon. Met 20 delen water verdunnen. Gereinigde delen moeten grondig afgespoeld en gedroogd worden.

OPTOCLEAN is een effectief en tegelijkertijd zacht reinigingsmiddel, dat ook voor gevoelige materialen zoals polycarbonaat en Trivex geschikt is.

3157 00  1 l

3157 25  2,5 l



Reinigingsvloeistofconcentraat

Alkalisch reinigingsconcentraat 1:9 voor sterk vervuilde metaalbrillen, sieraden en andere metalen delen, voor ultrasoons. Het bevat ammoniak en frist daardoor bonte- en edelmatalen optimaal op. Gereinigde delen moeten grondig afgespoeld en gedroogd worden.

Gebruik deze reiniger niet voor polycarbonaat-, Trivex- en ander gecoate kunststofglazen.

3158 00  1 l



Onze ultrasoons vindt u op pagina A 8 t/m A 11.





Onze glaskleurmachine Tinta 2 Nr. 2880 01 vindt u op pagina A 39.

Kleurpoeder

- Wateroplosbaar kleurpoeder voor het verven van brillenglazen
- Kant en klare dosering voor 1 liter verfbad
- Sachet lost in contact met warm water geheel op

2615 ..  10 g

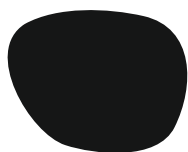

2615 01
Zwart

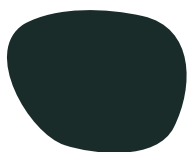

2615 02
Grijsgroen



2615 04
Staalgrijs

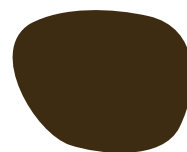

2615 06
Bruin

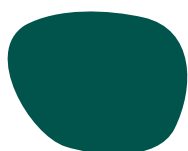

2615 11
Donkergroen

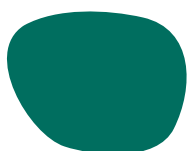

2615 12
Groen

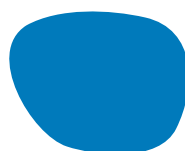

2615 17
Blauw



2615 23
Roze



2615 24
Rood



2615 26
Oranje

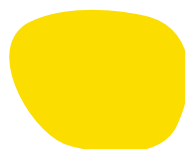

2615 29
Citroengeel

Additief UV-filter

- Wateroplosbaar poeder
- Voor het aanbrengen van een UV-filter op brillenglazen
- UV bescherming tot 400 nm
- Klant en klare dosering voor 1 liter verfbad
- Sachet lost in contact met warm water geheel op



2616 00  35 g

Hitte olie

- Een speciale olie, kan in plaats van gedestilleerd water gebruikt worden
- Geen vloeistofverlies door verdamping
- Uitermate geschikt voor veelvuldig gebruik



2617 00  1 l

Ontkleurder

- Voor het ontkleuren van brillenglazen



2618 00  1 l

Desinfectiedoeken – dispenser

- Geschikt voor reinigen en desinfecteren van oppervlakten van o.a. lens-, topsterkte- en keratometers enz.
- Omvangrijk spectrum tegen bacteriën, schimmels en virussen (HCV, HIV, Influenza A en B, polio)
- 100 stuks: 180 x 125 mm

3154 00



Desinfectiedoeken – navulling

- 100 stuks: 180 x 125 mm

3154 01





TIPS & TRICKS

PLASTI DIP RUBBER COATING

*Krasbescherming in een handomdraai!***Plasti Dip**

Bestelnr. 3169 20, 21, 22

Verdunner

Bestelnr. 3169 10

Mengbakje, spuit, spatel

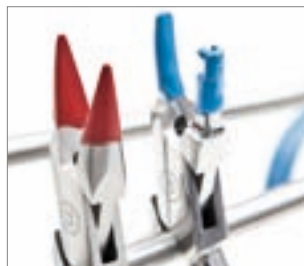
ca. 5–10 minuten
zonder droogtijd*Zo werkt het***Optie 1: Zonder verdunner** – voor gladde oppervlakken (vb. tangbekken)**1 REINIGEN****2 OMROEREN****3 ONVERDUND
OVERGIETEN****4 DIPPEN****5 DROGEN****Optie 2: Met verdunner** – voor oneffen oppervlakken (vb. bekken van een padrichttang) | **Herhaal de stappen 1–3****4 VULLEN****5 MENGEN EN DIPPEN****6 DROGEN****TIP:** Plasti Dip niet schudden om luchtballen te voorkomen. Onverdunde Plasti Dip kan na gebruik teruggegoten worden in het blik. Verdunde Plasti Dip kan in een afsluitbaar bakje bewaard worden.

Plasti Dip – professionele krasbescherming bij brilaanpassingen

Beschermd, geeft grip en blijft flexibel

Plasti Dip – de multifunctionele rubberen coating

- Geschikt voor metaal, glas, steen en hout
- Synthetische rubberen coating, die aan de lucht droogt
- Eenvoudig in gebruik door indopen of aanstippen
- Levensmiddelveilig in uitgeharde toestand
- Uitharding na 24 uur

Start Set

Bestaat uit 3 kleuren (zwart, blauw en rood) en een fles verdunner.

3169 51

Plasti Dip

3169 . .  429 ml

3169 20 Zwart

3169 21 Blauw

3169 22 Rood

Plasti Dip verdunner

3169 10  250 ml



Reparatiestiften

Met de reparatiestiften kunt u optimaal:

- Krassen bijwerken
 - Las- of soldeerresten bijwerken c.q. afdekken
 - Door transpiratie beschadigde monturen bijwerken
- Inzetbaar bij metalen en kunststof monturen.

2612 . .



▪ Leverbaar in 10 kleuren:

Bestelnr.	Kleur	Code
2612 20	Glanzend zwart	
2612 21	Matzwart	
2612 22	Donkerblauw	
2612 23	Goudgeel	
2612 24	Gun	

Bestelnr.	Kleur	Code
2612 25	Lichtzilver	
2612 26	Lichthavanna	
2612 27	Donkerhavanna	
2612 28	Beschermlak transparant glanzend	
2612 29	Beschermlak mat glanzend	

Reparatiestiftenset

Bestaand uit 10 stiften.

2612 51



- Het te repareren montuur of montuurdeel grondig reinigen
- Stift goed schudden en de punt meermaals indrukken tot de verf zichtbaar wordt
- De verf op de gewenste plek aanbrengen
- 10 tot 20 minuten laten drogen. Om het drogen te bespoedigen kan een föhn gebruikt worden
- Niet geschikt voor brandlakken





Reparatieverven





Kwaliteits lakverven voor kleine schoonheidscorrecties aan monturen, bijvoorbeeld bijwerken na een soldering. De verven laten zich mengen. De transparante lak kan voor kleine reparaties van beschermende lakken en voor optimalisering van een kleur gebruikt worden.

2611 . .  12 ml



▪ Leverbaar in 7 kleuren en transparante lak:

Bestelnr.	Kleur	Code
2611 00	Wit	
2611 01	Zwart	
2611 02	Zilver-metallic	
2611 03	Goud-metallic	

Bestelnr.	Kleur	Code
2611 04	Blauw	
2611 05	Rood	
2611 08	Bruin	
2611 09	Transparant lak	

Reparatievervenset

Bestaand uit alle 7 kleuren en transparante lak.

2611 51







- Het te repareren montuur of montuurdeel grondig reinigen
- Stift goed schudden tot de kogel in de stift duidelijk hoorbaar is
- De verf op de gewenste plek aanbrengen
- 6 uur laten drogen

Kleurpasta

Permanente kleurpasta, speciaal ontwikkelt voor het vullen van laser- of pantograafgravures/decoraties op kunststof en metalen oppervlakken. Om de gravures goed te vullen moet de pasta met een spatel o.i.d. aangebracht worden. Teveel aan pasta verwijderen. Bij kamertemperatuur 2–3 uur laten drogen.

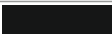
2609 . .  10 g



Bestelnr.	Kleur	Code
2609 00	Zwart	
2609 01	Wit	
2609 02	Goud	
2609 03	Zilver	



Glas decostiften

- Voor het kleuren van glasranden/-oppervlakken en nylordraad
- Op waterbasis en daardoor milieuvriendelijk
- Geschikt voor alle materialen inclusief carbonaat
- Één stift is genoeg voor meer dan 300 glazen
- De kleur is na ca. 30 minuten droog
- Eenvoudig wegvegen met aceton of spiritus, uitgezonderd polycarbonaat glazen



2610 ..

▪ Leverbaar in 14 kleuren:

Bestelnr.	Kleur	Code
2610 21 ●	Zwart	
2610 22 ●	Zwart mat	
2610 23	Wit	
2610 24 ●	Cognac	
2610 25 ●	Fuchsia	
2610 26 ●	Grijs	
2610 27 ●	Pruim	

Bestelnr.	Kleur	Code
2610 28 ●	Transparant	
2610 29 ●	Lichtturquoise	
2610 30 ●	Goud	
2610 31 ●	Zilver	
2610 32 ●	Blauw	
2610 33 ●	Bruin	
2610 34 ●	Bordeaux	

● Alle stiften als set leverbaar met Nr. 2610 52

Glas decostiften set

- Bestaand uit 13 stiften
- Wijzigingen voorbehouden

2610 52



Voor het gebruik a.u.b. de glasrand grondig met een speciale reiniger voor brillenglazen Nr. 3175 .. of in de ultrasoon reinigen. De beste resultaten worden verkregen, als men de randen niet of licht polijst. Voor gebruik schudden en de stift licht indrukken, zodat de verf in de stift loopt. Het aanbrengen van de verf wordt vergemakkelijkt indien men de glazen in een groefmachine zet. Vervolgens mag het glas alleen met de speciale reiniger voor brillenglazen schoongemaakt worden. De stift direct na gebruik goed sluiten, anders droogt deze uit.



TIPS & TRICKS

DE JUISTE COMBINATIE, DAAR KOMT HET OP AAN

*Polijstschijs?
+ Polijstwas?
= Perfecte
glans!*

*Zo werkt het*

ACETAAT, OPTYL, CELLULOID, PROPIONAA

VOORPOLIJSTEN

Polijstwas
Bestelnr. 3120 00

Lappenschijs, rondborstel
Bestelnr. 3416 10, 3474 00

FIJNPOLIJSTEN

Polijstwas
Bestelnr. 3118 00, 3123 00

Lappenschijs, rondborstel
Bestelnr. 3416 10, 3474 00

HOOGGLANSPOLIJSTEN

Polijstwas
Bestelnr. 3118 00, 3125 00,
Bestelnr. 3126 00

Lappenschijs, rondborstel
Bestelnr. 3470 01, 3471 00, 3472 00,
Bestelnr. 3561 00, 3571 00, 3582 00

POLYCARBONAAT

GLASPOLIJSTEN

Polijstwas
Bestelnr. 3127 00

Lappenschijs, rondborstel
Bestelnr. 3457 00

CR 39, TRIVEX, PNX

VOORPOLIJSTEN

Polijstwas
Bestelnr. 3126 00

Lappenschijs, rondborstel
Bestelnr. 3418 00, 3450 00, 3455 10,
Bestelnr. 3456 00

FIJNPOLIJSTEN

Polijstwas
Bestelnr. 3126 00, 3127 00

Lappenschijs, rondborstel
Bestelnr. 3457 00, 3474 00

STAAL, WIT- EN EDELMETALEN

VOORPOLIJSTEN

Polijstwas
Bestelnr. 3144 00

Lappenschijs, rondborstel
Bestelnr. 3416 10, 3470 01, 3471 00,
Bestelnr. 3472 00, 3474 00

FIJNPOLIJSTEN

Polijstwas
Bestelnr. 3143 00

Lappenschijs, rondborstel
Bestelnr. 3416 10, 3470 01, 3471 00,
Bestelnr. 3472 00, 3474 00

HOOGGLANSPOLIJSTEN

Polijstwas
Bestelnr. 3126 00

Lappenschijs, rondborstel
Bestelnr. 3470 01, 3471 00, 3472 00,
Bestelnr. 3561 00, 3571 00, 3582 00

BAKELIET, HOORN, RUBBER, METAAL

Polijstwas
zonder was

Lappenschijs, rondborstel
Bestelnr. 3462 00



Lappenschijf vilt

- Kern: Kunststof
- Boring-Ø: Conisch

Ø 100 mm | 15 mm

3418 00



Viltschijf conisch verloop, zacht vilt

- Kern: Gecentreerd
- Boring-Ø: 8 mm

Ø 100 mm | 20:5 mm

3450 00



Viltschijf

- Kern: Gecentreerd
- Boring-Ø: 8 mm

Ø 100 mm | 25 mm

3455 10



Viltschijf met groef

- Kern: Gecentreerd
- Boring-Ø: 8 mm

Ø 100 mm | 25 mm

3456 00



Lappenschijf van viltdoek voor Polycarbonaat

Voor een langere levensduur zijn de rode ringen per stuk afneembaar.

De lappenschijf van viltdoek is samen met de polijstwas

Nr. 3127 00 uitstekend geschikt voor het polijsten van polycarbonaatglazen. Optimaal toerental voor de bewerking van polycarbonaat: ca. 1.500 tpm.

- Kern: Kunststof
- Boring-Ø: Conisch

Ø 80 mm | 25 mm

3457 00



Lappenschijf leer

Is bijzonder geschikt voor eindpolijsten van metaal, rubber, paladon, bakeliet, hoorn enz.

De schijf **zonder** polijstmiddel, in ieder geval droog, gebruiken.

- Kern: Kunststof
- Boring-Ø: Conisch

Ø 90 mm | 6 mm

3462 00



Lappenschijf neteldoek

- Kern: Leer
- Boring-Ø: 6 mm

Ø 125 mm | 12 mm

3470 01



Lappenschijf neteldoek

- Kern: Leer
- Boring-Ø: 6 mm

Ø 125 mm | 24 mm

3471 00



Lappenschijf flanel

- Kern: Leer
- Boring-Ø: 6 mm

∅ 125 mm | 30 mm

3474 00



Lappenschijf

- Kern: Kunststof
- Boring-Ø: 8 mm

∅ 100 mm | 10 mm

3416 10



Rondborstel wol

- Kern: Hout
- Boring-Ø: 6 mm

∅ 70 mm | 35 mm

3561 00



Rondborstel katoengaren

- Kern: Kunststof
- Boring-Ø: Conisch

∅ 90 mm | 20 mm

3575 00



Gesiliconiseerde lappenschijf neteldoek

De weefselstructuur met siliconen biedt aanzienlijke voordelen: ze verhoogt de levensduur van de schijf omdat er geen pluïsvorming is, u heeft minder druk nodig bij het polijsten en u bespaart 50 % polijstpasta.

- Kern: Kunststof
- Boring-Ø: 6 mm

∅ 100 mm | 12 mm

3472 00



Rondborstel wol

- Kern: Kunststof
- Boring-Ø: Conisch

∅ 80 mm | 25 mm

3582 00



Wolkegel

De wolkegel is zo gemaakt dat deze op een polijstspits gemonteerd kan worden. Een andere bevestigingsmogelijkheid is niet beschikbaar. Een geheel rustige loop is door de verlengde as niet mogelijk.

- Kern: Hout
- Boring-Ø: Conisch

∅ 30:15 mm | 70 mm

3571 00



„De juiste combinatie, daar komt het op aan”
(zie pagina E 27)



Om het rafelen van lappenschijven te voorkomen kunt u deze voor het eerste gebruik tijdens de loop met een scherp voorwerp aansnijden. Als materiaal kan katoen niet geheel zonder rafels zijn.

Voor alle lappenschijven met kunststof kern

Kunststof kernen hebben conische boringen. Bij het monteren op de polijstspits moet het conische verloop van spits en boring overeenstemmen.



Voor een veilige loop van de wolkegel, voor gebruik testen of de kegel minstens 2 cm op de polijstspits gedraaid kan worden.



Voor alle slijpschijven gelden de „Europese veiligheidsmaatregelen voor het juiste gebruik van slijpschijven”:

1. Schijven moeten vanaf een gezamenlijke diameter an 100 mm tot 2/3 gedeelte aan beide zijden geflenst zijn.
2. Het maximale toerental moet in acht worden genomen.
3. Tijdens het slijpen is het verplicht een veiligheidsbril te dragen (zie handelsartikelen-catalogus).



Polirood

3143 00



Gebruik bij ca. 2.800 tpm:	Voor- en fijnpolijsten: Lappenschijven van doek
Inzetbaar voor:	Goud, staal
Gewicht:	ca. 60 g

Poligroen

3144 00



Gebruik bij ca. 2.800 tpm:	Voor- en fijnpolijsten: Lappenschijven van doek
Inzetbaar voor:	Witmetaal
Gewicht:	ca. 60 g

Poliblaauw

3145 00



Gebruik bij ca. 2.800 tpm:	Voor- en fijnpolijsten: Lappenschijven van doek	Voor- en fijnpolijsten: Lappenschijven van doek
Inzetbaar voor:	Witmetaal	Kunststof en rubber
Gewicht:	ca. 60 g	ca. 60 g

Glanswas, geel

3126 00



Gebruik bij ca. 3.500 tpm:	Hoogglanspolijsten: Lappenschijven van doek
Inzetbaar voor:	Edelstaal, aluminium, metalen, kunststoffen
Gewicht:	ca. 500 g



Kijkt u ook eens ons assortiment klein polijstgereedschap incl. siliconenpolijsters Nr. 2240 57 op pagina C 31.

Slijpwash, grijs**3120 00****Polijswash, blauw****3118 00**

Gebruik bij ca. 2.800 tpm:	Voorpolijsten: Lappenschijven van doek (ca. 2.300 tpm)	Voor- en fijnpolijsten: Wolborstels, lappenschijven van doek
Inzetbaar voor:	Kunststoffen	Kunststoffen, optyl
Gewicht:	ca. 200 g	ca. 700 g

Glanswash, beige**3123 00****Glanswash, beige****3125 00**

Gebruik bij ca. 3.500 tpm:	Spiegelglanspolijsten: Wolborstels, lappenschijven van doek	Hoogglanspolijsten: Wolborstels
Inzetbaar voor:	Kunststoffen	Kunststoffen
Gewicht:	ca. 200 g	ca. 200 g

Polijswash, blauw, voor polycarbonaat

Deze pasta is een hoogglanspolijstpasta met „diamantine” en is uitermate geschikt voor zowel het polijsten van **polycarbonaatglazen** als de materialen **titanium, platinum en palladium**. Uiterst geschikt in combinatie met lappenschijf **Nr. 3457 00** (zie pagina E 28).

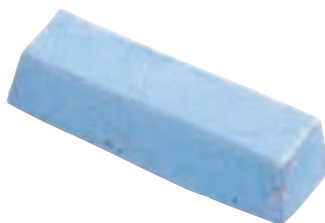
3127 00

Gebruik bij ca. 2.800 tpm:	Hoogglanspolijsten: Lappenschijf viltdoek, wolborstels
Inzetbaar voor:	Polycarbonaat, titanium, palladium
Gewicht:	ca. 100 g



„De juiste combinatie, daar komt het op aan”
(zie pagina E 27)



Onze polijstmotoren vindt u
op pagina A 24 en A 25.

Schuurstok, vlak

- Werkoppervlak: 230 x 18 x 4 mm

3253 ..  2 stuks

3253 10 Korrel: 100

3253 22 Korrel: 220

3253 40 Korrel: 400



Schuurstok, driekant

- Werkoppervlak: 230 x 11 mm
- Werkhoek: 60°

3254 ..  2 stuks

3254 10 Korrel: 100

3254 22 Korrel: 220

3254 40 Korrel: 400



Schuurstok, half rond

- Werkoppervlak: 230 x 17 x 12 mm

3255 ..  2 stuks

3255 10 Korrel: 100

3255 22 Korrel: 220

3255 40 Korrel: 400



Complete set schuurstokken

- Uitvoeringen: vlak, driekant, half rond
- Korrel: 100, 220 en 400



3253 99  18 stuks (elk 2 per korrel en model)

Schuurpapier

3251 ..  230 x 280 mm

 5 vellen

3251 18 Korrel: 180

3251 40 Korrel: 400

3251 24 Korrel: 240

3251 60 Korrel: 600

3251 32 Korrel: 320

3251 80 Korrel: 800



Schuurblok rubbe

Voor de bewerking van soldeerpunten,
het matteren van metalen en kunststoffen.

3412 ..  80 x 20 x 50 mm

3412 01 Korrel: Grof

3412 02 Korrel: Middel

3412 03 Korrel: Fijn



Matteer borstel

- Kern: Kunststof
- Boring-Ø: Conisch
- Draadsterkte: 0,6 mm
- Toerental: max. 2800 tpm

Voor het aanbrengen van een houtstructuur op acetaatmateriaal.

3510 00 ∅ 100 mm



Messing reinigingsborstels

- Kern: Metaal
- Boring-Ø: Conisch

3506 00

∅ 50 mm | 10 mm | 25 g



Gereedschapreiniger diamant

Potloodvorm, 1.500 fijne staaldraden zorgen voor reiniging van boren, frezen en diamantboren. De hardheid is traploos verstelbaar.

3501 00 | 120 mm



Vijlborstel

- Vlak
- Werkend oppervlak: 105 mm

3516 00 250 x 35 mm



Kraspen

- Met hardmetalen punt
- Ballpoint formaat
- Schuifmechanisme voorkomt verwondingen
- Met zwarte kunststofgreep ter optimalisering van het gebruik
- Reserve punten verkrijgbaar

2302 00 | 117 mm



Reserve punten

- Hardmetaal

2302 10 2 stuks

Slijpschijf van steen bros

- Korrel: 46
- Toerental, max.: 4.780 tpm
- Boring-Ø: 8 mm

3426 10

∅ 100 mm | 20 mm | 260 g

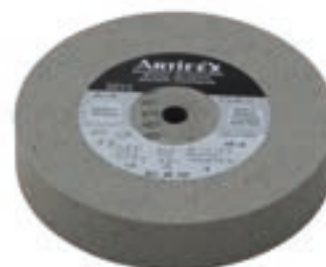

Toebehoren voor soldeer- en lasapparaten

Gasfles

- Voor handsoldeerapparaat Nr. 2763 00 en Micro-Torch set Nr. 2762 05 en 2762 00 (uitverkocht)
- Vloeibaar gas
- Brandduur: ca. 3,5 uur bij een kleine vlam

2761 06  70 ml



Navulpatroon gas

- Voor handsoldeerapparaat Nr. 2727 30 (uitverkocht)
- Butaangas

2737 01  400 ml



Zuurstoffles

- Voor Micro-Torch set Nr. 2762 05 en 2762 00 (uitverkocht)
- Zuurstof (niet vloeibaar)

2760 02  13 g



Het betreft hier geen vloeibare zuurstof.
De patroon heeft een gebruiksduur van ca. 45 minuten.



Overeenkomstig de wettelijke voorschriften worden zuurstof en gas in afzonderlijke verpakking geleverd.

Soldeerdraadhouder

Voor Degussa soldeerrol Nr. 3007 00.
Opening: 1,8 mm



2059 00  200 mm  20 g

Lasdraad voor laser- of WIG lasapparaten

Zilver palladiumdraad

Alleen te gebruiken bij **nikkelhoudende** monturen, zoals bijvoorbeeld **monel of nieuwzilver**.
Materiaaldikte: 0,4 mm

3043 30  2 à 25 cm



Titaniumdraad

Alleen te gebruiken bij **titanium monturen**.
Materiaaldikte: 0,3 mm

3043 10  2 à 25 cm



Elektrolyt

3198 00  800 ml



Flux

3199 01  1 l



Hittestop

- Isoleerpasta voor alle solderingen
- Voorkomt het geleiden van las- en soldeerwarmte in metaal
- Samenstelling: Pasta

3029 00  100 g



Vloeimiddel BrazeTec h 80

- Voor moeilijk te verwerken materialen, zoals **roestvrij staal**
- Laat geen resten na op de soldeerplek
- Samenstelling: Pasta

3114 00  100 g



Vloeimiddel BrazeTec h

- Samenstelling: Pasta

3112 00  100 g

3112 05  500 g



Bij uitdroging kunnen vloeimiddel en hittestop met water bespreid worden.

Zilver solderpasta, witvloeiend

- Voor sieraden en monturen
- Zonder bijkomend vloeimiddel gebruiken
- Metaalgehalte: 56 % Ag
- Werktemperatuur: 650 °C
- Geleverd als/uitvoering: Pasta in patroon

3002 00  8 g



witvloeiend, bevat vloeimiddel



Ons soldeerapparaat Nr. 2039 60 en accessoires vindt u op pagina A 31 t/m A 33.



Hardsoldeer zilver**3003 00**

Te gebruiken voor:	Brons, nikkel, RVS
Metaalgehalte:	60 % Ag zonder Cd
Werktemperatuur:	680 °C
Aanbevolen vloeimiddel:	3112 . . BrazeTec h
Geleverd als/uitvoering:	Draad 0,5 mm Ø
Verpakking:	5 g
Lengte:	ca. 230 cm

Zilver solder Degussa 600 L 3**3007 00**

Te gebruiken voor:	Het solderen van sieraden
Metaalgehalte:	60 % Ag zonder Cd
Werktemperatuur:	680 °C
Aanbevolen vloeimiddel:	3112 . . BrazeTec h
Geleverd als/uitvoering:	Draad 0,4 mm Ø in dispenser
Verpakking:	2 g
Lengte:	ca. 110 cm

Zilver solder Degussa 6002 zonder Cd**3008 00**

Te gebruiken voor:	Bestek, sieraden
Metaalgehalte:	60 % Ag, 23 % Cu, 14,5 % Zn, 2,5 % Sn
Werktemperatuur:	680 °C
Aanbevolen vloeimiddel:	3112 . . BrazeTec h
Geleverd als/uitvoering:	Draad 0,5 mm Ø
Verpakking:	5 g
Lengte:	ca. 280 cm

Fantomsoldeer**3010 00**

Te gebruiken voor:	Oefenmateriaal, ook voor nikkelvrije materialen
Metaalgehalte:	55 % Ag, Sn
Werktemperatuur:	660 °C
Aanbevolen vloeimiddel:	3112 . . BrazeTec h
Geleverd als/uitvoering:	Draad 0,5 mm Ø in dispenser
Verpakking:	3 g
Lengte:	ca. 130 cm

Soldeerdraad, witvloeiend**3014 00**

Te gebruiken voor:	Het solderen van alle sieraadlegeringen met en boven 800 ‰ fijnzilveragehalte
Metaalgehalte:	675 ‰ Ag
Werktemperatuur:	710 °C
Aanbevolen vloeimiddel:	3112 . . BrazeTec h
Geleverd als/uitvoering:	Draad 0,4 mm Ø
Verpakking:	5 g
Lengte:	ca. 230 cm

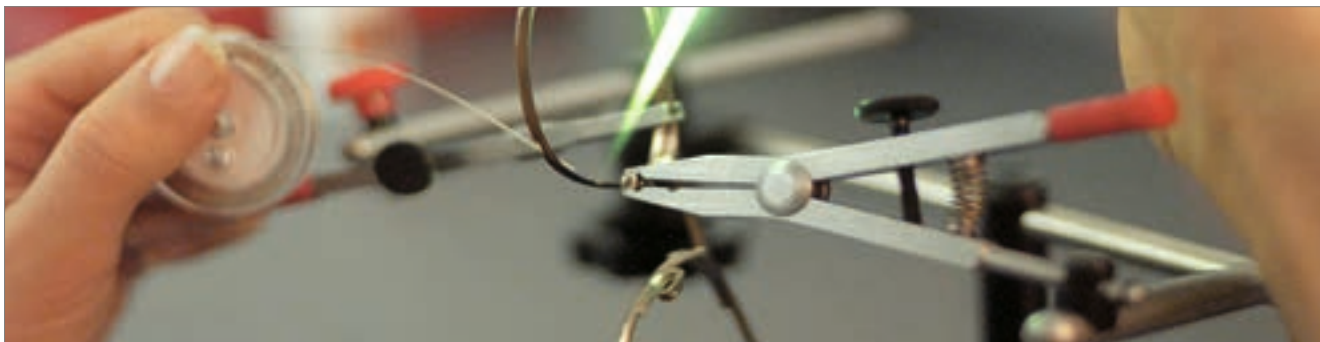

Goudsoldeer- draad, 8 Kt

3016 00



Soldeerdraad, geelvloeiend

3015 00



Te gebruiken voor:	Sieraden en monturen van goudlegeringen	Alle standaard metalen zoals zilver, nikkel, chroom, RVS, messing e.a.
Metaalgehalte:	333 ‰ Au	55 % Ag, 21 % Cu, 22 % Zn, 2 % Sn
Werktemperatuur:	590 °C	660 °C
Aanbevolen vloeimiddel:	3112 . . BrazeTec h	3112 . . BrazeTec h
Geleverd als/uitvoering:	Draad 0,5 mm Ø	Draad 0,4 mm Ø
Verpakking:	1 g	5 g
Lengte:	ca. 70 cm	ca. 75 cm

Soldeerstaaf, witvloeiend

3022 03



witvloeiend, bevat vloeimiddel

Te gebruiken voor:	Alle standaard metalen zoals zilver, nikkel, chroom, RVS, messing e.a.
Metaalgehalte:	40 % Ag
Werktemperatuur:	700 °C
Aanbevolen vloeimiddel:	Zonder vloeimiddel gebruiken
Geleverd als/uitvoering:	Staaftje 1 mm Ø
Verpakking:	3 staaftjes à 150 mm

Pallarium – Universele soldeerstaaf, witvloeiend

3023 00



witvloeiend, bevat vloeimiddel

Te gebruiken voor:	Alle standaard metalen zoals nikkel, zilver, chroom, RVS, goud, messing e.a.
Metaalgehalte:	45 % Ag
Werktemperatuur:	580 °C
Aanbevolen vloeimiddel:	Zonder vloeimiddel gebruiken
Geleverd als/uitvoering:	Staaftje 1 mm Ø
Verpakking:	12 staaftjes à 150 mm

Pallarium – Universele soldeerstaaf, goudvloeiend

3023 01



goudvloeiend, bevat vloeimiddel

Te gebruiken voor:	Alle standaard metalen zoals nikkel, zilver, chroom, RVS, goud, messing e.a.
Metaalgehalte:	33 % Ag
Werktemperatuur:	620 °C
Aanbevolen vloeimiddel:	Zonder vloeimiddel gebruiken
Geleverd als/uitvoering:	Staaftje 1 mm Ø
Verpakking:	12 staaftjes à 150 mm





BRILONDERDELEN

in exacte dosering met doeltreffende werking



- F 2 Overzicht neuspads
- F 13 Plakpads, padplaatjes
- F 14 Tips & tricks: zelfklevende neuspadkussen
- F 16 Tips & tricks: padsteunen
- F 17 Padsteunen
- F 20 Overzicht schroeven en moeren
- F 33 Tips & tricks: 4-in-1-schroeven
- F 50 Ringen en hulzen
- F 54 Scharnieren
- F 58 Overzicht oortips en veren
- F 66 Tips & tricks: kruloortips
- F 74 Tips & tricks: krimpkous
- F 76 Lange oortips
- F 77 Veren
- F 81 Onderdelen voor glasbrillen
- F 84 Inlegrand
- F 85 Nylordraad
- F 86 Oefenmateriaal



Het B & S neuspadassortiment:

- Uitgebreide keuze
- Voor alle toepassingen
- Snel vinden voor eenvoudig bestellen



3 stappen bij bestelling

1. Selecteer het materiaal (inhoud rechts)
2. Selecteer grootte en vorm
3. Selecteer type montage

Montagesystemen



Klik-
systeem



Schroef-
systeem



Schroef- EN
Kliksysteem

Handig om te weten

f&w & De pictogrammen garanderen:

- Hoogwaardige basismaterialen
- Maximale duurzaamheid en optische transparantie
- Kleurecht
- Geen vliesvorming



f&w Made in Germany Premium neuspads bieden u:

- Siliconenpads van medische siliconen voor hoogste transparantie
- PVC pads zonder ftalaathoudende weekmakers
- Ontbreken van spuitpunten voor beter draagcomfort
- Afgeronde kanten
- Hoge dimensionale nauwkeurigheid en hoge kwaliteit van de samengestelde materialen
- Gecertificeerd volgens DIN EN ISO 9001 en 13485

Logic[®]

Smart, Universal Nose Pads

U.S. Patent No. 5.872.612

Hilco Logic[®] pads:

- Gepatenteerde neuspads, passend voor schroef- en kliksysteem
- Premium anti-slip siliconen
- Vermindert de voorraad neuspads tot wel 50 %





Gemakkelijk te vinden in één oogopslag

	Siliconenpads <ul style="list-style-type: none"> ▪ Symmetrisch ▪ Extra dun, symmetrisch ▪ Rond en classic 	F 4 F 4 F 5
	Comfortpads <ul style="list-style-type: none"> ▪ Air Active ▪ Biofeel 	F 6 F 6
	Siliconenpads en TPE pads <ul style="list-style-type: none"> ▪ Zadelpads ▪ „Systeem 3” ▪ Primadonna systeem ▪ Air Titanium en Minimal Art 	F 7 F 7 F 8 F 8
	PVC pads, halfhard <ul style="list-style-type: none"> ▪ Primadonna systeem ▪ Air Titanium en Minimal Art ▪ Met kunststofkern ▪ Met metaalkern 	F 8 F 8 F 9 F 9
	Kunststof pads, hard <ul style="list-style-type: none"> ▪ Extra dun 	F 10
	Speciale pads en neusbruggen <ul style="list-style-type: none"> ▪ Pads, specifieke modellen ▪ ic! berlin neuspads ▪ Logic® ▪ Siliconen neusbruggen ▪ Pads voor Ray Ban monturen 	F 11 F 11 F 11 F 11 F 12
	Speciale pads, anti-allergisch <ul style="list-style-type: none"> ▪ Glas ▪ Titanium 	F 12 F 12
	Neuspaddkussen <ul style="list-style-type: none"> ▪ Schuimrubber ▪ Siliconen 	F 13 F 14–F 15
	Padsteunen <ul style="list-style-type: none"> ▪ Voor kunststof monturen ▪ Voor metalen monturen 	F 16–F 18 F 19
	Assortiments <ul style="list-style-type: none"> ▪ Siliconenpad assortiment 	F 5

Siliconenpads







Klikpads symmetrisch

 10,0 mm ↔	f&w	0227 10	20 stuks
		0227 10-100	100 stuks
		0227 10-200	200 stuks
 13,0 mm ↔	f&w	0227 13	20 stuks
		0227 13-100	100 stuks
		0227 13-200	200 stuks
 14,5 mm ↔	f&w	0227 15	20 stuks
		0227 15-100	100 stuks
		0227 15-200	200 stuks
 16,0 mm ↔	f&w	0227 16	20 stuks
		0227 16-100	100 stuks
		0227 16-200	200 stuks
 18,0 mm ↔	f&w	0227 18	20 stuks
		0227 18-100	100 stuks
		0227 18-200	200 stuks





Schroefpads symmetrisch

 10,0 mm ↔	f&w	0228 10	20 stuks
		0228 10-100	100 stuks
		0228 10-200	200 stuks
 13,0 mm ↔	f&w	0228 13	20 stuks
		0228 13-100	100 stuks
		0228 13-200	200 stuks
 14,5 mm ↔	f&w	0228 15	20 stuks
		0228 15-100	100 stuks
		0228 15-200	200 stuks
 16,0 mm ↔	f&w	0228 16	20 stuks
		0228 16-100	100 stuks
		0228 16-200	200 stuks
 18,0 mm ↔	f&w	0228 18	20 stuks
		0228 18-100	100 stuks
		0228 18-200	200 stuks



Klikpads symmetrisch, extra dun

 13,0 mm ↔		0219 13	20 stuks
		0219 13-50	50 stuks
		0219 13-100	100 stuks
 15,0 mm ↔		0219 15	20 stuks
		0219 15-50	50 stuks
		0219 15-100	100 stuks



Schroefpads symmetrisch, extra dun

 13,0 mm ↔		0229 13	20 stuks
		0229 13-50	50 stuks
		0229 13-100	100 stuks
 15,0 mm ↔		0229 15	20 stuks
		0229 15-50	50 stuks
		0229 15-100	100 stuks

Siliconenpads





Klikpads rond en classic

	f&w	0278 09	20 stuks
		0278 09-100	100 stuks
9,0 mm			
	f&w	0216 15	10 paar
		0216 15-50	50 paar
15,0 mm		0216 15-100	100 paar
	f&w	0216 17	10 paar
		0216 17-50	50 paar
17,0 mm		0216 17-100	100 paar
	f&w	0216 19	10 paar
		0216 19-50	50 paar
19,0 mm		0216 19-100	100 paar



Schroefpads rond en classic

	f&w	0288 09	20 stuks
		0288 09-100	100 stuks
9,0 mm			
	f&w	0226 15	10 paar
		0226 15-50	50 paar
15,0 mm		0226 15-100	100 paar
	f&w	0226 17	10 paar
		0226 17-50	50 paar
17,0 mm		0226 17-100	100 paar
	f&w	0226 19	10 paar
		0226 19-50	50 paar
19,0 mm		0226 19-100	100 paar

Siliconenpad assortiment

In de klapbox Nr. 1458 20.

Inhoud: 12 soorten van de meest gangbare siliconen pads en neusbruggen, totaal 172 stuks
Wijzigingen voorbehouden.

0200 10

 210 g



Onze onderdelenboxen vindt u op pagina G 12 en G 13.



Comfortpads



Air Active Pads

zijn gemaakt van extreem flexibel siliconen materiaal en bieden een **verhoogd draagcomfort door een luchtkussen**. Drukpunten worden vermeden.

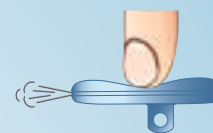

Air Active Pads, symmetrisch, kliksysteem	
 13,0 mm	f&w 0296 13 met kunststofkern 10 stuks
 14,5 mm	f&w 0296 14 met kunststofkern 10 stuks
 17,0 mm	f&w 0296 17 met kunststofkern 10 stuks

Air Active Pads, symmetrisch, schroefstelsysteem	
 11,0 mm	f&w 0297 11 10 stuks
 14,5 mm	f&w 0297 14 10 stuks
 17,0 mm	f&w 0297 17 10 stuks
 14,5 mm	f&w 0297 25 met kunststofkern 10 stuks

„System 3 AirTec“

 11,0 mm	f&w 0298 11 10 stuks
-------------	---

„System 3 AirTec“

 11,9 mm	f&w 0298 12 10 stuks
-------------	---



Biofeel Pads

zijn gemaakt van flexibel siliconen materiaal en bieden een **verhoogd draagcomfort door een gelkussen**. Drukpunten worden vermeden.



Biofeel Pads, kliksysteem	
 12,5 mm	0214 01 2 paar
 12,5 mm	0214 10 10 paar

Biofeel Pads, schroefstelsysteem	
 12,5 mm	0211 01 2 paar
 12,5 mm	0211 10 10 paar

Siliconenpads en TPE



Siliconen zadelpads klik

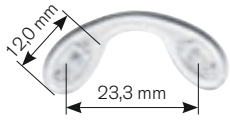

f&w 0225 12 3 stuks
0225 12-9 9 stuks

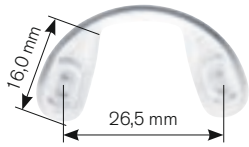

f&w 0225 16 3 stuks
0225 16-9 9 stuks

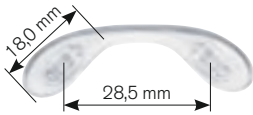

f&w 0225 18 3 stuks
0225 18-9 9 stuks



Siliconen zadelpads schroef

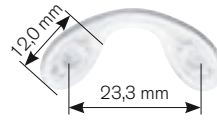

f&w 0235 12 3 stuks
0235 12-9 9 stuks

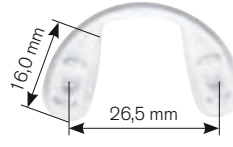

f&w 0235 16 3 stuks
0235 16-9 9 stuks

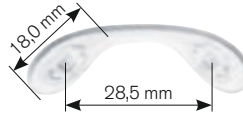

f&w 0235 18 3 stuks
0235 18-9 9 stuks

„Systeem 3” Siliconen



f&w 0279 11 20 stuks



f&w 0279 13 20 stuks



f&w 0279 51 10 paar
wigvormig

„Systeem 3 Dash M” Siliconen



f&w 0276 11 20 stuks

Met gemoderniseerde, flexibeler steun voor een beter draagcomfort.

„Systeem 3” TPE (thermoplastische elastomeer)



f&w 0274 11 20 stuks







De passende padsteunen Nr. 0276 01 vindt u op pagina F 19.



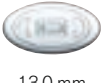

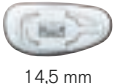

Siliconenpads en PVC pads, halfhard





Primadonna systeem Siliconen

 9,0 mm	f&w	0280 09	20 stuks
 13,0 mm	f&w	0212 13	20 stuks
		0212 13-100	100 stuks
 14,5 mm	f&w	0212 15	10 paar
			



Primadonna systeem PVC

 13,0 mm	f&w	0213 13	20 stuks
		0213 13-100	100 stuks
 14,5 mm	f&w	0213 15	10 paar
			

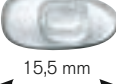







Air Titanium en Minimal Art Siliconen

 8,0 mm	f&w	0279 08	20 stuks
		0279 08-100	100 stuks
 9,0 mm	f&w	0279 09	20 stuks
		0279 09-100	100 stuks
 9,5 mm	f&w	0279 10	20 stuks
		0279 10-100	100 stuks
		Hogere stabiliteit door ingezette kunststof stift.	
 12,0 mm	f&w	0279 12	20 stuks
			
 15,5 mm	f&w	0279 15	20 stuks
			
 11,0 mm		0270 11	10 paar
			













Air Titanium en Minimal Art PVC

 9,5 mm	f&w	0271 09	20 stuks
 11,5 mm	f&w	0271 11	20 stuks
			

PVC pads, halfhard, met kunststofkern

 Transparant, kliksysteem				 Transparant, schroefstelsysteem			
	f&w	0272 09	20 stuks		f&w	0273 09	20 stuks
9,0 mm		0272 09-100	100 stuks	9,0 mm		0273 09-100	100 stuks
	f&w	0272 13	20 stuks		f&w	0273 13	20 stuks
13,0 mm		0272 13-100	100 stuks	13,0 mm		0273 13-100	100 stuks
	f&w	0272 15	10 paar		f&w	0273 15	10 paar
14,5 mm		0272 15-50	50 paar	14,5 mm		0273 15-50	50 paar
	f&w	0272 17	10 paar		f&w	0273 17	10 paar
17,0 mm		0272 17-50	50 paar	17,0 mm		0273 17-50	50 paar

PVC pads, halfhard, met metaalkern

 Transparant, goud, kliksysteem				 Transparant, goud, schroefstelsysteem			
		0231 15	20 stuks			0256 15	20 stuks
15,0 mm				15,0 mm			
 Transparant, zilver, kliksysteem				 Transparant, zilver, schroefstelsysteem			
		0230 15	20 stuks			0255 12	20 stuks
15,0 mm				12,0 mm			
		0230 15	20 stuks			0255 15	20 stuks
15,0 mm				15,0 mm			
		0255 17	20 stuks			0255 17	20 stuks
				17,5 mm			

Kunststof pads, hard



Extra dun, bijzonder transparante,
lichte uitvoering, kliksysteem



0253 22

20 stuks



Extra dun, bijzonder transparante,
lichte uitvoering, schroefstelsel



0254 22

20 stuks



Bijzonder transparante,
lichte uitvoering, kliksysteem



f&w

0253 12

20 stuks



Bijzonder transparante,
lichte uitvoering, schroefstelsel



f&w





0254 12

20 stuks

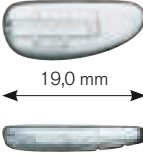

Speciale pads en neusbruggen

Pads, specifieke modellen



		0201 07	20 stuks
7,0 mm		PVC	Insteken
	f&w	0267 14	10 stuks
14,0 mm		Siliconen	Pocket systeem
		0277 01	3 paar
19,0 mm		Siliconen	Verticaal insteken

icl berlin neuspads

	icl berlin 	0264 01	4 stuks
14,0 mm		Thermo-plastische elastomeer	Verticaal insteken
	icl berlin 	0264 02	4 stuks
14,0 mm		Thermo-plastische elastomeer	Verticaal insteken
	icl berlin 	0264 03	4 stuks
14,0 mm		Thermo-plastische elastomeer	Verticaal insteken

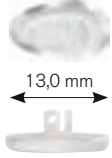

Schroef- en klikpads Logic[®], symmetrisch

	Logic[®]	0217 13	20 stuks
13,0 mm		0217 13-100	100 stuks
	Logic[®]	0217 15	20 stuks
15,0 mm		0217 15-100	100 stuks

Siliconen neusbruggen, klein

	f&w	0241 01	3 stuks
14,9 mm		Goud kern, voor metalen monturen	
	f&w	0241 10	3 stuks
14,9 mm		Zilver kern, voor metalen monturen	

Siliconen neusbruggen, groot





	f&w	0242 01	3 stuks
16,9 mm		Goud kern, voor metalen monturen	
	f&w	0242 10	3 stuks
16,9 mm		Zilver kern, voor metalen monturen	











Speciale pads

	Glas, allergievrij, kliksysteem		
		0248 13	10 stuks
13,0 mm			
		0248 15	10 stuks
15,0 mm			









	Glas, allergievrij, schroefstelsysteem		
		0249 13	10 stuks
13,0 mm			
		0249 15	10 stuks
15,0 mm			

	Titanium, allergievrij, kliksysteem		
	f&w	0257 08	4 stuks
8,0 mm			
		0257 08-10	10 stuks
Gepolijst			
	f&w	0203 01	4 stuks
13,0 mm			
Gepolijst			
	f&w	0203 02	4 stuks
13,0 mm			
Gematteerd			

	Titanium, allergievrij, schroefstelsysteem		
	f&w	0258 08	4 stuks
8,0 mm			
		0258 08-10	10 stuks
Gepolijst			
	f&w	0204 01	4 stuks
13,0 mm			
Gepolijst			
	f&w	0204 02	4 stuks
13,0 mm			
Gematteerd			

	Siliconen met titanium kern, allergievrij, schroefstelsysteem		
		0259 01	4 stuks
13,0 mm			
			

Pads voor Ray Ban monturen

	0243 02	10 stuks	
15,0 mm			
	Soft-PVC		Ray Ban (B & L)
	0243 03	10 stuks	
15,0 mm			
	Soft-PVC		Ray Ban (B & L)
	0243 12	10 stuks	
15,0 mm			
	Siliconen		Ray Ban (B & L)
	0243 13	10 stuks	
15,0 mm			
	Siliconen		Ray Ban (B & L)

Siliconen

Siliconen



De passende padsteunen Nr. 0299 02 vindt u op pagina F 19.

Neuspadkussen, padplaatjes



Painex – neuspadkussen assortiment

Voor vermindering van de neussteunbreedte.

Schuimrubber, zelfklevend, wit.

1 strip = 4 paar

Inhoud: 9 strips à 1,0 mm dikte

12 strips à 1,5 mm dikte

9 strips à 2,0 mm dikte

0739 00

Verhoogt het draagcomfort
van kunststof monturen

Painex – neuspadkussen

Per dikte.

1 strip = 4 paar

Inhoud: 12 strips

0739 10 $\frac{+}{-}$ 1,0 mm

0739 15 $\frac{+}{-}$ 1,5 mm

0739 20 $\frac{+}{-}$ 2,0 mm



0,8 > 2,0 mm

Padplaatjes om te kitten

Asymmetrische padplaatjes om op kunststof monturen te kitten.

Als lijm is bv aceton Nr. 3173 00 geschikt.

Inhoud: 6 paar

0263 00 $\frac{|}{|}$ 19 x 8 mm $\frac{+}{-}$ 0,8 > 2,0 mm





TIPS & TRICKS

ZELFKLEVENDE NEUSPADKUSSEN

Één kussen, 2 varianten

Neuspadkussen assortiment

Bestelnr. 0758 50

of per stuk:

Zelfklevende neuspadkussen

Bestelnr. 0758 01, 02, 03



5 minuten

Zo werkt het



Optie 1: Afsnijden

1 MONTUUR REINIGEN



2 FOLIE HALF VERWIJDEREN

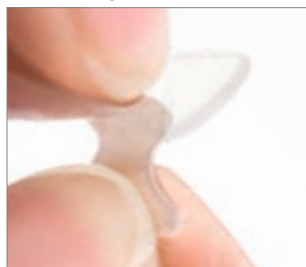

3 PLAKKEN



4 AFSNIJDEN



5 KLAAR



Optie 2: Omvouwen | Herhaal de stappen 1-3

4 FOLIE GEHEEL VERWIJDEREN



5 LAATSTE EIND OMFUWEN



6 KLAAR



Neuspadkussen

Zelfklevende **siliconenfolie**.

Breedte: elk 7 mm

Inhoud: 10 paar

0758 01 Maat S 

0758 02 Maat M 

0758 03 Maat L 



Neuspadkussen assortiment

Inhoud: elk 10 paar van Nr. 0758 01; 0758 02 en 0758 03

0758 50  30 paar



Vanwege achterlating van restanten van bijv. cosmetica, huidvet o.i.d. wordt wisselen na 3 tot 4 weken aanbevolen.





Neuspadkussen

Zelfklevende **siliconenfolie**.

Inhoud: 20 stuks

0748 13 

0748 15 

0748 17 

0748 19 

0748 23 

0748 25 

0748 27 

0748 29 



Bijna onzichtbaar

Neuspadkussen assortiment

Inhoud: elk 20 stuks van Nr. 0748 13; 0748 15; 0748 17 en 0748 19

0748 50  80 stuks

Neuspadkussen assortiment

Inhoud: elk 20 stuks van Nr. 0748 23; 0748 25; 0748 27 en 0748 29

0748 51  80 stuks





TIPS & TRICKS

PADSTEUNEN VOOR KUNSTSTOF MONTUREN

Past altijd!

Montageset

Bestelnr. 0304 50

of per stuk:

Padsteunen, beta-titanium

Bestelnr. 0304 01, 03, 05, 06, 11, 15, 16, 21, 25, 26

Bestelnr. 0305 01, 03, 05, 06, 11, 15, 16, 21, 25, 26

Montagewerktuig

Bestelnr. 0304 00

Spiraalboren, HSS

Bestelnr. 2032 15

Kunststof pad

Bestelnr. 0227 10, 0228 10

Padschroeven

Bestelnr. 0896 00

Gereedschaphouder

Bestelnr. 2068 00

Staalrees

Bestelnr. 2240 41

Universele stift

Bestelnr. 2623 01



15 minuten

Zo werkt het

1 FREZEN



2 POLIJSTEN



3 MARKEREN



4 BOREN



5 INSPANNEN



6 INZETTEN



7 BEVESTIGEN



8 KLAAR



Kunststof monturen voor iedereen

De hoogwaardige, in Japan, geproduceerde padsteunen van Beta titanium verbeteren het draagcomfort van een niet ideaal passende kunststof montuur, omdat deze te allen tijde anatomisch kunnen worden aangepast. Zowel door hun sierlijke vorm, als verschillende kleur- en maatmogelijkheden zijn ze onopvallend en een opwaardering voor elk montuur.



Beta titanium

- Montage d.m.v. éénpunts systeem
- Kleine boring voldoende
- Montage slechts door insteekverbinding
- Passende boor: Nr. 2032 15



Kliksysteem

0304 . .

2 paar

Maat S 10 mm		Maat L 12 mm		Maat XL 16 mm	
Bestelnr.	Kleur	Bestelnr.	Kleur	Bestelnr.	Kleur
0304 21	Zilver	0304 01	Zilver	0304 11	Zilver
0304 25	Zwart	0304 03	Bruin	0304 15	Zwart
0304 26	Goud	0304 05	Zwart	0304 16	Goud
		0304 06	Goud		

Schroefstelsysteem

0305 . .

2 paar

Maat S 10 mm		Maat L 12 mm		Maat XL 16 mm	
Bestelnr.	Kleur	Bestelnr.	Kleur	Bestelnr.	Kleur
0305 21	Zilver	0305 01	Zilver	0305 11	Zilver
0305 25	Zwart	0305 03	Bruin	0305 15	Zwart
0305 26	Goud	0305 05	Zwart	0305 16	Goud
		0305 06	Goud		

Markeerhulp „APP”

De Accurate Point Positioner werd ontwikkeld om een precieze en exacte boorpunt positie van de kunststof en Beta titanium padsteunen Nr. 0303 . ., 0304 . ., en 0305 . . te garanderen.

Met de nieuwe versie van APP kunt u nu ook de boorpunten in horizontale en verticale richting perfect aanpassen.

0303 10



Montagewerktuig voor beta-titanium padsteunen

- Voor het eenvoudig monteren van titanium padsteunen
- Licht prettig in de hand
- Maakt precisiewerken mogelijk

0304 00



Montageset padsteunen Beta titanium

- **Inhoud:** Gereedschap voor padsteunen, 16 paar padsteunen, passende boor (Nr. 2032 15) en neuspads (Nr. 0227 10 en 0228 10 en padschroeven (Nr. 0896 00)
- In handige box

0304 50

105 x 23,5 x 178 mm



De passende schroeven Nr. 0896 00, 0896 00TL en 0896 20 (lengte 4,0 mm, schroefdraad 1,0 mm) vindt u op pagina F 22.



Padsteunen voor kunststof monturen

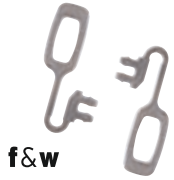

f&w

Type/Inzetbaar:
„Systeem 3” en „Systeem 3 Dash M”
Kleur: Zilver

0307 01

5 paar

Neusbruggen met padsteunen voor kunststof monturen



- Kliksysteem
- Montage door twee parallelle boringen van 1,0 mm
- Afstand tussen boringen: 12 mm
- Fixatie d.m.v. 2 pins aansluiting
- Kleur: Zilver

0306 02

2 stuks



- Schroefstelsysteem
- Montage door twee parallelle boringen van 1,0 mm
- Afstand tussen boringen: 12 mm
- Fixatie d.m.v. 2 pins aansluiting
- Kleur: Zilver

0306 01

2 stuks



Padsteunen voor metalen monturen



Type/Inzetbaar:
Universeel inzetbaar
Kleur: Zilver

0288 01  10 stuks



Type/Inzetbaar:
Universeel inzetbaar
Kleur: Goud

0288 02  10 stuks



Type/Inzetbaar:
Universeel inzetbaar
Kleur/materiaal: Titanium

f&w **0288 03**  10 stuks



Type/Inzetbaar:
Universeel inzetbaar
Kleur: Zilver

f&w **0289 01**  10 stuks



Type/Inzetbaar:
Universeel inzetbaar
Kleur: Zilver

0287 01  5 paar



Type/Inzetbaar:
Universeel inzetbaar
Kleur: Goud

0287 02  5 paar



Type/Inzetbaar:
Universeel inzetbaar
Kleur/materiaal: Titanium

f&w **0287 03**  5 paar



Type/Inzetbaar:
Pads met klemsysteem
Kleur: Goud

0299 02  5 paar



De passende neuspads vindt u op pagina F 12 bij
Nr. 0243 02, 0243 03, 0243 12 en 0243 13.



Type/Inzetbaar:
Pocket pads
Kleur: Zilver

f&w **0281 01**  5 paar



Type/Inzetbaar:
„System 3” und „System 3 Dash M”
Kleur: Zilver

f&w **0276 01**  10 stuks



De passende neuspads „System 3” und „System 3 Dash M”
vindt u op pagina F 7.



Het B & S schroevenassortiment:

- Uitgebreide keuze
- Voor alle toepassingen
- Snel vinden voor eenvoudig bestellen



3 stappen bij bestelling

OPTION

A	Oplopende schroefdraadmaat	F 22–F 32
----------	----------------------------	-----------

1. Selecteer de schroefdraad (Option A)
2. Selecteer het type schroef
3. Selecteer de kleur

OPTION

B	Schroeven voor speciale toepassing	F 33–F 44
----------	------------------------------------	-----------

1. Speciale schroef kiezen (Option B)
2. Selecteer de grootte
3. Selecteer de kleur

Onderstaande pictogrammen maken uw selectie gemakkelijk

Schroeven voor:	Vormen:	Afmetingen:
 Neuspads	 Gleufschroef	 Schroevenzekering
 Sluitblokken	 Kruiskopschroef	 Schroefdraad
 Scharnieren	 Kruiskop/gleuf combinatie	 Kopdiameter
 Glasbrillen	 Stermoer	 Totale lengte
	 Zeskantschroef/-moer	 Diameter
	 Torx schroef	 Diameter binnen
		 Diameter buiten

OPTION

A

**Schroeven volgens schroefdraad**

0,8–1,0 mm	F 22
1,1 mm	F 23
1,2 mm	F 23–F 24
1,3 mm	F 25
1,4 mm	F 25–F 29
1,5 mm	F 30–F 31
1,6 mm	F 31–F 32
1,7–1,8 mm	F 32

OPTION

B

**Speciale schroeven**

4-in-1-schroeven	F 33–F 35
Glasbrilschroeven	F 36
Schroeven voor Ray Ban monturen	F 37
Torx schroeven	F 38
Schroeven voor kunststof scharnieren	F 39
Flexscharnier schroeven	F 39–F 40
Flexscharnier schroeven met blauwe zekering	F 41
Hilco Logic® schroeven	F 42
Schroeven met transparante zekering	F 43
Veerschroeven	F 43
Schroeven met zwarte zekering	F 44
Schroeven met blauwe Tuflock	F 44

En nog veel meer

Passschroeven	F 32
Assortiment	F 45–F 47
Moeren	F 48–F 49
Ringen	F 50–F 51
Hulzen	F 52–F 53



Oplopend in schroefdraaddiameter



0,8 mm schroefdraad

		Functie	Schroefkop	Materiaal	Kleur			Bestel-nr.	€		Passende moer
				Nieuw-zilver	Zilver	3,70	1,30	0805 10	8,-	100 stuks	-



1,0 mm schroefdraad

		Functie	Schroefkop	Materiaal	Kleur			Bestel-nr.		Passende moer
				Staal	Zilver	3,80	1,80	0865 01	100 stuks	-
				Staal	Goud	3,80	1,80	0865 10	100 stuks	-
				Nieuw-zilver	Zilver	4,00	1,20	0815 00	100 stuks	-
				Nieuw-zilver	Zilver	4,00	1,40	0896 00	100 stuks	-
				Nieuw-zilver	Goud	4,00	1,40	0896 10	100 stuks	-
				Nieuw-zilver	Gun	4,00	1,40	0896 20	100 stuks	-
				Nieuw-zilver	Zilver	4,00	1,40	0896 00TL	50 stuks	-
				Staal	Zilver	4,45	1,40	0807 00	100 stuks	-
				Staal	Zilver	4,50	1,80	0889 00	100 stuks	-
				Staal	Zilver	5,80/ 2,80	1,40	0819 05	100 stuks	-
				Staal	Zilver	5,80/ 2,80	1,40	0819 05TL	50 stuks	-
				Staal	Goud	5,80/ 2,80	1,40	0819 15	100 stuks	-
				Staal	Goud	5,80/ 2,80	1,40	0819 15TL	50 stuks	-
				Staal	Zilver	12,80/ 2,80	1,40	0816 000	50 stuks	-
				Staal	Goud	12,80/ 2,80	1,40	0816 100	50 stuks	-
				Staal	Gun	12,80/ 2,80	1,40	0816 200	50 stuks	-





1,1 mm schroefdraad

		Functie	Schroef-kop	Materiaal	Kleur			Bestel-nr.		Passende moer
				Nieuw-zilver	Zilver	4,20	1,30	0803 00	100 stuks	-



1,2 mm schroefdraad

		Functie	Schroef-kop	Materiaal	Kleur			Bestel-nr.		Passende moer
				Staal	Zilver	1,30	1,80	0801 00	100 stuks	-
				Staal	Zilver	2,60	1,60	0860 40	100 stuks	-
				Staal	Zilver	3,00	2,00	0886 03	100 stuks	-
				Staal	Gun voor kunststof scharnieren	3,00	2,30	0833 20	50 stuks	-
				Staal	Zilver	3,20	1,60	0853 00	100 stuks	-
				Staal	Zilver	3,40	1,60	0882 00	100 stuks	-
				Staal	Goud	3,40	1,60	0882 10	100 stuks	-
				Staal	Zilver	3,50	2,00	0886 04	100 stuks	-
				Staal	Zilver	3,90	2,00	0886 00	100 stuks	-
				Staal	Zilver	4,00	1,40	0896 01	100 stuks	-
				Staal	Zilver	4,00	2,00	0886 05	100 stuks	-
				Staal	Zilver	4,40	2,00	0886 01	100 stuks	-
				Staal	Zilver	4,70	1,60	0871 00	100 stuks	-
				Nieuw-zilver	Zilver	4,80	1,60	0818 00	100 stuks	-
				Staal	Zilver	4,90	2,00	0886 02	100 stuks	-
				Staal	Zilver	5,90/ 3,50	2,00	0819 03	100 stuks	-
				Staal	Zilver	5,90/ 3,50	2,00	0819 03TL	50 stuks	-
				Staal	Goud	5,90/ 3,50	2,00	0819 13	100 stuks	-
				Staal	Goud	5,90/ 3,50	2,00	0819 13TL	50 stuks	-



Schroevenzekering



Oplopend in schroefdraaddiameter



1,2 mm schroefdraad

		Functie	Schroef-kop	Materiaal	Kleur			Bestel-nr.		Passende moer
				Staal	Gun	5,90/ 3,50	2,00	0819 23	100 stuks	-
				Staal	Gun	5,90/ 3,50	2,00	0819 23TL	50 stuks	-
				Staal	Zilver	7,00	2,00	0883 00	100 stuks	-
				Staal	Zilver	7,00/ 4,00	2,00	0819 08	100 stuks	-
				Staal	Zilver	7,50/ 4,50	2,00	0819 09	100 stuks	-
				Staal	Zilver	10,00	2,40	0885 00	100 stuks	-
				Staal	Zilver	10,70	2,50	0857 00	100 stuks	0822 01TL
				Staal	Zilver	11,60	2,00	0888 00	25 stuks	-
				Staal	Goud	11,60	2,00	0888 10	25 stuks	-
				Staal	Zwart	11,60	2,00	0888 20	25 stuks	-
				Nieuw-zilver	Zilver	12,00	1,80	0831 00	100 stuks	0822 01TL
				Messing	Goud	12,00	1,80	0831 10	100 stuks	0822 02TL
				Messing	Gun	12,00	1,80	0831 20	100 stuks	0822 03
				Nieuw-zilver	Zilver	12,00	2,50	0841 01	100 stuks	0822 01TL
				Nieuw-zilver	Goud	12,00	2,50	0841 11	100 stuks	0822 02TL
				Staal	Zilver	12,60	2,20	0858 00	100 stuks	0831 02
				Staal	Goud	12,60	2,20	0858 10	100 stuks	0831 12
				Staal	Zilver	14,80/ 4,80	1,80	0816 001	50 stuks	-
				Staal	Goud	14,80/ 4,80	1,80	0816 101	50 stuks	-
				Staal	Gun	14,80/ 4,80	1,80	0816 201	50 stuks	-
				Nieuw-zilver	Zilver	15,00	1,80	0843 00	100 stuks	0822 01TL
				Staal	Zilver	15,50/ 5,50	1,80	0816 012	50 stuks	-





1,3 mm schroefdraad

		Functie	Schroef-kop	Materiaal	Kleur			Bestel-nr.		Passende moer
				Staal	Zilver	3,50	1,70	0880 00	100 stuks	-
				Staal	Goud	3,50	1,70	0880 10	100 stuks	-
				Nieuw-zilver	Zilver	5,30	1,70	0804 00	100 stuks	-
				Nieuw-zilver	Gun	5,30	1,70	0804 20	100 stuks	-
				Staal	Zilver	6,50/ 3,50	2,00	0819 06	100 stuks	-
				Staal	Zilver	6,50/ 3,50	2,00	0819 06TL	50 stuks	-
				Staal	Goud	6,50/ 3,50	2,00	0819 16	100 stuks	-
				Staal	Goud	6,50/ 3,50	2,00	0819 16TL	50 stuks	-
				Staal	Zilver	7,00	1,80	0861 00	100 stuks	-
				Nieuw-zilver	Zilver	8,00	2,80	0848 00	100 stuks	-
				Staal	Zilver	11,50	1,80	0861 01	50 stuks	-
				Staal	Goud	11,50	1,80	0861 11	50 stuks	-
				Staal	Zilver	11,60	2,00	0888 01	25 stuks	-
				Staal	Goud	11,60	2,00	0888 11	25 stuks	-
				Staal	Zwart	11,60	2,00	0888 21	25 stuks	-
				Staal	Zilver	14,80/ 4,80	1,80	0816 002	50 stuks	-
				Staal	Goud	14,80/ 4,80	1,80	0816 102	50 stuks	-
				Staal	Gun	14,80/ 4,80	1,80	0816 202	50 stuks	-



1,4 mm schroefdraad

		Functie	Schroef-kop	Materiaal	Kleur			Bestel-nr.		Passende moer
				Staal	Zilver	2,50	2,20	0878 00	100 stuks	-
				Staal	Zilver	2,70	2,00	0870 00	100 stuks	-



































































































Schroevenzekering



Oplopend in schroefdraaddiameter



1,4 mm schroefdraad

		Functie	Schroef- kop	Materiaal	Kleur			Bestel- nr.		Passende moer
				Staal	Zilver	2,80	1,80	0851 01	100 stuks	-
				Staal	Zilver	3,00	2,00	0811 00	50 stuks	-
				Staal TX4	Zilver	3,00	2,00	0887 03	100 stuks	-
				Staal	Zilver	3,10	2,00	0874 00	100 stuks	-
				Staal	Zilver	3,30	2,00	0869 01	100 stuks	-
				Staal	Zilver	3,40	1,80	0851 02	100 stuks	-
				Staal	Zilver	3,45	2,00	0854 00	100 stuks	-
				Staal	Zilver	3,50	2,00	0811 01	50 stuks	-
				Staal TX4	Zilver	3,50	2,00	0887 04	100 stuks	-
				Staal	Zilver	3,60	2,00	0884 00	100 stuks	-
				Staal	Zilver	3,70	2,00	0869 02	100 stuks	-
				Staal	Zilver	3,90	2,00	0869 00	100 stuks	-
				Staal	Zilver	3,90	1,80	0872 00	100 stuks	-
				Staal	Goud	3,90	1,80	0872 10	100 stuks	-
				Staal	Gun	3,90	1,80	0872 20	100 stuks	-
				Staal TX4	Zilver	3,90	2,00	0887 00	100 stuks	-
				Staal	Zilver	4,00	1,80	0851 03	100 stuks	-
				Staal	Zilver	4,00	2,00	0876 00	100 stuks	-
				Staal	Zilver	4,00	2,00	0811 02	50 stuks	-
				Staal TX4	Zilver	4,00	2,00	0887 05	100 stuks	-
				Staal	Zilver	4,10	1,80	0860 55	100 stuks	-
				Nieuw- zilver	Zilver	4,20	1,80	0814 00	200 stuks	-
				Staal	Zilver	4,20	1,80	0876 01	100 stuks	-
				Staal	Zilver	4,20	2,00	0869 03	100 stuks	-





1,4 mm schroefdraad





































		Functie	Schroefkop	Materiaal	Kleur			Bestel-nr.		Passende moer
				Staal	Zilver	4,30	1,80	0851 00	100 stuks	-
				Staal	Zilver	4,30	2,00	0867 00	100 stuks	-
				Staal	Goud	4,30	2,00	0868 00	100 stuks	-
				Staal	Zilver	4,40	1,80	0873 00	100 stuks	-
				Staal	Zilver	4,40	2,00	0884 01	100 stuks	-
				Staal	Zilver	4,40	2,00	0887 01	100 stuks	-
				Staal	Zilver	4,50	2,00	0811 03	50 stuks	-
				Staal	Zilver	4,70	2,00	0884 02	100 stuks	-
				Nieuw-zilver	Zilver	4,80	2,50	0821 00	100 stuks	-
				Staal	Zilver	4,90	2,00	0887 02	100 stuks	-
				Nieuw-zilver	Zilver	5,00	1,80	0820 00	200 stuks	-
				Staal	Zilver	5,20	1,80	0860 20	100 stuks	-
				Nieuw-zilver	Zilver	5,40	1,80	0852 00	100 stuks	-
				Staal	Zilver	6,00	1,80	0860 58	100 stuks	-
				Staal	Zilver	6,00	1,80	0860 58TL	50 stuks	-
				Staal	Zilver	6,50	1,80	0860 30	100 stuks	-
				Staal	Zilver	6,50	1,80	0860 30TL	50 stuks	-
				Staal	Zilver	6,50	2,00	0813 00	100 stuks	-
				Staal	Zilver	6,50/ 3,50	2,00	0819 00	100 stuks	-
				Staal	Zilver	6,50/ 3,50	2,00	0819 00TL	50 stuks	-
				Staal	Zilver	7,00/ 4,00	2,00	0819 01	100 stuks	-
				Staal	Zilver	7,00/ 4,00	2,00	0819 01TL	50 stuks	-
				Staal	Zilver	7,80/ 4,80	2,00	0819 02	100 stuks	-
				Staal	Goud	6,50/ 3,50	2,00	0819 10	100 stuks	-



Oplopend in schroefdraaddiameter



1,4 mm schroefdraad





		Functie	Schroef- kop	Materiaal	Kleur			Bestel- nr.		Passende moer
				Staal	Goud	6,50/ 3,50	2,00	0819 10TL	50 stuks	-
				Staal	Goud	7,00/ 4,00	2,00	0819 11	100 stuks	-
				Staal	Goud	7,00/ 4,00	2,00	0819 11TL	50 stuks	-
				Staal	Goud	7,80/ 4,80	2,00	0819 12	100 stuks	-
				Staal	Gun	6,50/ 3,50	2,00	0819 20	100 stuks	-
				Staal	Gun	6,50/ 3,50	2,00	0819 20TL	50 stuks	-
				Staal	Zilver voor kunststof scharnieren	7,80	2,00	0855 00	50 stuks	-
				Nieuw- zilver	Zilver	8,60	2,80	0828 10	100 stuks	-
				Staal	Zilver	8,50/ 5,50	2,00	0819 010	100 stuks	-
				Staal	Zilver	9,50/ 6,50	2,00	0819 011	100 stuks	-
				Staal	Zilver	10,00	2,80	0885 01	100 stuks	-
				Staal	Zilver	10,60/ 3,60	1,80	0817 00	100 stuks	-
				Staal	Goud	10,60/ 3,60	1,80	0817 10	100 stuks	-
				Staal	Gun	10,60/ 3,60	1,80	0817 20	100 stuks	-
				Staal	Zilver	10,60	2,80	0835 00	100 stuks	0824 01TL
				Staal	Goud	10,60	2,80	0835 10	100 stuks	0824 02TL
				Staal	Zilver voor kunststof scharnieren	10,80	2,00	0855 01	50 stuks	-
				Nieuw- zilver	Zilver	11,40	2,80	0824 11	100 stuks	0824 01TL
				Nieuw- zilver	Goud	11,40	2,80	0824 14	100 stuks	0824 02TL
				Staal	Zilver	11,50	1,80	0862 01	50 stuks	-
				Staal	Goud	11,50	1,80	0862 11	50 stuks	-
				Staal	Zilver	11,60	2,00	0888 02	25 stuks	-
				Staal	Goud	11,60	2,00	0888 12	25 stuks	-
				Staal	Zwart	11,60	2,00	0888 22	25 stuks	-



Oplopend in schroefdraaddiameter



1,4 mm schroefdraad





		Functie	Schroefkop	Materiaal	Kleur			Bestel-nr.		Passende moer
			●	Nieuw-zilver	Zilver	12,00	2,50	0841 00	100 stuks	0824 01TL
			●	Messing	Goud	12,00	2,50	0841 10	100 stuks	0824 02TL
			●	Nieuw-zilver	Gun	12,00	2,50	0841 20	100 stuks	0824 03
			+	Staal	Zilver	12,60	2,50	0857 01	100 stuks	0824 01TL
			●	Staal	Zilver	12,60	2,20	0858 01	100 stuks	0831 04
			●	Staal	Goud	12,60	2,20	0858 11	100 stuks	0831 14
			●	Staal	Zilver	13,00/ 3,00	1,80	0816 003	50 stuks	-
			●	Staal	Goud	13,00/ 3,00	1,80	0816 103	50 stuks	-
			●	Staal	Gun	13,00/ 3,00	1,80	0816 203	50 stuks	-
			●	Staal	Zilver	14,80/ 4,80	1,80	0816 004	50 stuks	-
			●	Staal	Goud	14,80/ 4,80	1,80	0816 104	50 stuks	-
			●	Staal	Gun	14,80/ 4,80	1,80	0816 204	50 stuks	-
			●	Staal	Zilver	13,50/ 3,50	2,00	0816 007	50 stuks	-
			●	Staal	Goud	13,50/ 3,50	2,00	0816 107	50 stuks	-
			●	Staal	Gun	13,50/ 3,50	2,00	0816 207	50 stuks	-
			●	Staal	Zilver	14,00/ 4,00	2,00	0816 008	50 stuks	-
			●	Staal	Goud	14,00/ 4,00	2,00	0816 108	50 stuks	-
			●	Staal	Gun	14,00/ 4,00	2,00	0816 208	50 stuks	-
			●	Staal	Zilver	14,80/ 4,80	2,00	0816 009	50 stuks	-
			●	Staal	Goud	14,80/ 4,80	2,00	0816 109	50 stuks	-
			●	Staal	Gun	14,80/ 4,80	2,00	0816 209	50 stuks	-
			●	Nieuw-zilver	Zilver	15,00	1,80	0843 01	100 stuks	0824 01TL
			●	Nieuw-zilver	Goud	15,00	1,80	0843 11	100 stuks	0824 02TL
			●	Staal	Zilver	15,50/ 5,50	2,00	0816 013	50 stuks	-



Oplopend in schroefdraaddiameter



1,5 mm schroefdraad

		Functie	Schroefkop	Materiaal	Kleur			Bestel-nr.		Passende moer
				Nieuw-zilver	Zilver	5,00	1,80	0845 15	100 stuks	-
				Staal voor kunststof scharnieren	Zilver	5,00	2,00	0855 04	50 stuks	-
				Staal	Zilver	5,20	1,80	0842 00	100 stuks	-
				Staal	Zilver	5,20	1,80	0842 00TL	50 stuks	-
				Staal	Goud	5,20	1,80	0842 10	100 stuks	-
				Staal	Gun	5,20	1,80	0842 20	100 stuks	-
				Staal	Zilver	6,50/ 3,50	2,00	0819 07	100 stuks	-
				Staal	Zilver	6,50/ 3,50	2,00	0819 07TL	50 stuks	-
				Staal	Goud	6,50/ 3,50	2,00	0819 17	100 stuks	-
				Staal	Goud	6,50/ 3,50	2,00	0819 17TL	50 stuks	-
				Nieuw-zilver	Zilver	10,00	2,80	0827 00	100 stuks	-
				Staal	Zilver	10,00	2,80	0885 02	100 stuks	-
				Staal	Zilver	11,50	1,80	0863 01	50 stuks	-
				Staal	Goud	11,50	1,80	0863 11	50 stuks	-
				Staal	Zilver	11,60	2,00	0888 03	25 stuks	-
				Staal	Goud	11,60	2,00	0888 13	25 stuks	-
				Staal	Zwart	11,60	2,00	0888 23	25 stuks	-
				Staal	Zilver	14,00/ 4,00	1,80	0816 005	50 stuks	-
				Staal	Goud	14,00/ 4,00	1,80	0816 105	50 stuks	-
				Staal	Gun	14,00/ 4,00	1,80	0816 205	50 stuks	-
				Staal	Zilver	14,80/ 4,80	1,80	0816 006	50 stuks	-
				Staal	Goud	14,80/ 4,80	1,80	0816 106	50 stuks	-
				Staal	Gun	14,80/ 4,80	1,80	0816 206	50 stuks	-
				Staal	Zilver	14,00/ 4,00	2,00	0816 010	50 stuks	-



Oplopend in schroefdraaddiameter



1,5 mm schroefdraad

		Functie	Schroef-kop	Materiaal	Kleur			Bestel-nr.		Passende moer
				Staal	Goud	14,00/ 4,00	2,00	0816 110	50 stuks	-
				Staal	Gun	14,00/ 4,00	2,00	0816 210	50 stuks	-
				Staal	Zilver	14,80/ 4,80	2,00	0816 011	50 stuks	-
				Staal	Goud	14,80/ 4,80	2,00	0816 111	50 stuks	-
				Staal	Gun	14,80/ 4,80	2,00	0816 211	50 stuks	-



1,6 mm schroefdraad

		Functie	Schroef-kop	Materiaal	Kleur			Bestel-nr.		Passende moer
				Staal	Zilver	3,50	2,50	0811 04	50 stuks	-
				Staal	Zilver	4,00	2,50	0855 06	50 stuks	-
				Staal	Zilver	4,00	2,50	0811 05	50 stuks	-
				Staal	Zilver	4,60	2,50	0811 06	50 stuks	-
				Staal	Zilver	5,20	1,80	0842 01	100 stuks	-
				Staal	Zilver	5,20	1,80	0842 01TL	50 stuks	-
				Staal	Goud	5,20	1,80	0842 11	100 stuks	-
				Staal	Gun	5,20	1,80	0842 21	100 stuks	-
				Staal	Zilver	5,20	2,50	0855 07	50 stuks	-
				Staal	Zilver	6,00	2,50	0855 05	50 stuks	-
				Staal	Zilver	6,50/ 3,50	2,00	0819 04	100 stuks	-
				Staal	Zilver	6,50/ 3,50	2,00	0819 04TL	50 stuks	-
				Staal	Goud	6,50/ 3,50	2,00	0819 14	100 stuks	-
				Staal	Goud	6,50/ 3,50	2,00	0819 14TL	50 stuks	-
				Staal	Zilver	7,80	2,00	0855 02	50 stuks	-



Schroevenzekering



Oplopend in schroefdraaddiameter



1,6 mm schroefdraad

		Functie	Schroef-kop	Materiaal	Kleur			Bestel-nr.		Passende moer
				Nieuw-zilver	Zilver	9,00	2,80	0837 10	100 stuks	-
				Staal	Zilver	10,00	2,80	0885 03	100 stuks	-
				Staal voor kunststof scharnieren	Zilver	10,80	2,00	0855 03	50 stuks	-
				Staal	Zilver	11,60	2,00	0888 04	25 stuks	-
				Staal	Goud	11,60	2,00	0888 14	25 stuks	-
				Staal	Zwart	11,60	2,00	0888 24	25 stuks	-



1,7 mm schroefdraad

		Functie	Schroef-kop	Materiaal	Kleur			Bestel-nr.		Passende moer
				Nieuw-zilver	Zilver	7,30	2,80	0834 00	100 stuks	-



1,8 mm schroefdraad

		Functie	Schroef-kop	Materiaal	Kleur			Bestel-nr.		Passende moer
				Staal	Zilver	11,60	2,00	0888 05	25 stuks	-
				Staal	Goud	11,60	2,00	0888 15	25 stuks	-
				Staal	Zwart	11,60	2,00	0888 25	25 stuks	-

Passchroeven voor metalen brillen

	Materiaal	Kleur			Bestel-nr.		
	Nieuw-zilver	Zilver	1,20	40,00	0881 12	1 stuk	Voor gebruik aan het sluitblok ter controle van de glasmaat
	Nieuw-zilver	Zilver	1,30	40,00	0881 13	1 stuk	



Schroevenzekering



TIPS & TRICKS

4 vliegen in één klap!

4-in-1-schroef

Bestelnr. 0816..

Opticienschroevendraaier

Bestelnr. 1664 14

Schroefhouderpincet

Bestelnr. 1651 00



elk ca. 3 minuten



Zo werkt het

SLUITBLOK

1 SCHROEF INSTEKEN



2 AANSCHROEVEN



3 AFBREKEN



SCHARNIER

1 SCHROEF INSTEKEN



2 AANSCHROEVEN



3 AFBREKEN



4 KLAAR



Speciale schroeven

4 vliegen in één klap!







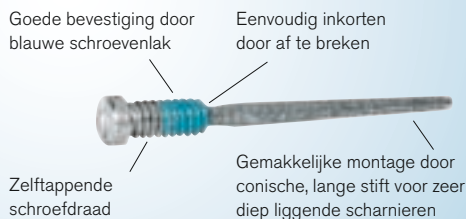

















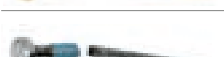





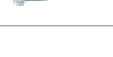

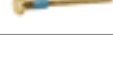























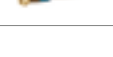

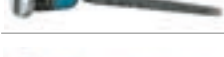



Met de 4-in-1 schroef is het schroeven van diepliggende sluitblokken en flexscharnieren simpeler dan ooit tevoren. De lange conisch gevormde stift vereenvoudigt het insteken en wordt daarna afgebroken. Dankzij het zelftappende schroefdraad en borgmiddel is verdere bewerking niet nodig.



4-in-1-schroeven



		Schroef-kop	Materiaal	Kleur				Bestel-nr.		Passende moer
			Staal	Zilver	1,00	12,80/ 2,80	1,40	0816 000	50 stuks	-
			Staal	Goud	1,00	12,80/ 2,80	1,40	0816 100	50 stuks	-
			Staal	Gun	1,00	12,80/ 2,80	1,40	0816 200	50 stuks	-
			Staal	Zilver	1,20	14,80/ 4,80	1,80	0816 001	50 stuks	-
			Staal	Goud	1,20	14,80/ 4,80	1,80	0816 101	50 stuks	-
			Staal	Gun	1,20	14,80/ 4,80	1,80	0816 201	50 stuks	-
			Staal	Zilver	1,20	15,50/ 5,50	1,80	0816 012	50 stuks	-
			Staal	Zilver	1,30	14,80/ 4,80	1,80	0816 002	50 stuks	-
			Staal	Goud	1,30	14,80/ 4,80	1,80	0816 102	50 stuks	-
			Staal	Gun	1,30	14,80/ 4,80	1,80	0816 202	50 stuks	-
			Staal	Zilver	1,40	13,00/ 3,00	1,80	0816 003	50 stuks	-
			Staal	Goud	1,40	13,00/ 3,00	1,80	0816 103	50 stuks	-
			Staal	Gun	1,40	13,00/ 3,00	1,80	0816 203	50 stuks	-
			Staal	Zilver	1,40	14,80/ 4,80	1,80	0816 004	50 stuks	-
			Staal	Goud	1,40	14,80/ 4,80	1,80	0816 104	50 stuks	-
			Staal	Gun	1,40	14,80/ 4,80	1,80	0816 204	50 stuks	-
			Staal	Zilver	1,40	13,50/ 3,50	2,00	0816 007	50 stuks	-
			Staal	Goud	1,40	13,50/ 3,50	2,00	0816 107	50 stuks	-

4-in-1-schroeven										
		Schroef- kop	Materiaal	Kleur				Bestel- nr.		Passende moer
			Staal	Gun	1,40	13,50/ 3,50	2,00	0816 207	50 stuks	-
			Staal	Zilver	1,40	14,00/ 4,00	2,00	0816 008	50 stuks	-
			Staal	Goud	1,40	14,00/ 4,00	2,00	0816 108	50 stuks	-
			Staal	Gun	1,40	14,00/ 4,00	2,00	0816 208	50 stuks	-
			Staal	Zilver	1,40	14,80/ 4,80	2,00	0816 009	50 stuks	-
			Staal	Goud	1,40	14,80/ 4,80	2,00	0816 109	50 stuks	-
			Staal	Gun	1,40	14,80/ 4,80	2,00	0816 209	50 stuks	-
			Staal	Zilver	1,40	15,50/ 5,50	2,00	0816 013	50 stuks	-
			Staal	Zilver	1,50	14,00/ 4,00	1,80	0816 005	50 stuks	-
			Staal	Goud	1,50	14,00/ 4,00	1,80	0816 105	50 stuks	-
			Staal	Gun	1,50	14,00/ 4,00	1,80	0816 205	50 stuks	-
			Staal	Zilver	1,50	14,80/ 4,80	1,80	0816 006	50 stuks	-
			Staal	Goud	1,50	14,80/ 4,80	1,80	0816 106	50 stuks	-
			Staal	Gun	1,50	14,80/ 4,80	1,80	0816 206	50 stuks	-
			Staal	Zilver	1,50	14,00/ 4,00	2,00	0816 010	50 stuks	-
			Staal	Goud	1,50	14,00/ 4,00	2,00	0816 110	50 stuks	-
			Staal	Gun	1,50	14,00/ 4,00	2,00	0816 210	50 stuks	-
			Staal	Zilver	1,50	14,80/ 4,80	2,00	0816 011	50 stuks	-
			Staal	Goud	1,50	14,80/ 4,80	2,00	0816 111	50 stuks	-
			Staal	Gun	1,50	14,80/ 4,80	2,00	0816 211	50 stuks	-

 „4 vliegen in één klap“
(zie pagina F 33)

4-in-1-schroeven assortiment

Inhoud: 7 verschillende 4-in-1-schroeven (350 stuks)

0816 050  43 g

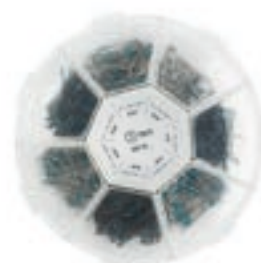







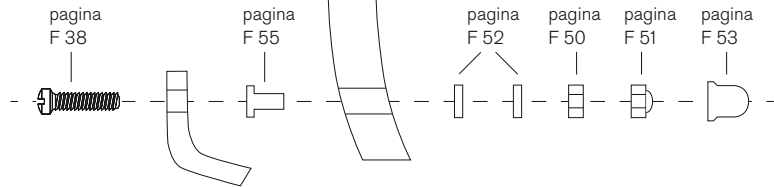





















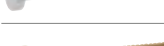

































Speciale schroeven

Glasbrilschroeven



























De volgende onderdelen vindt u op



		Schroef- kop	Materiaal	Kleur				Bestel- nr.		Passende moer
			Staal	Zilver	1,20	10,70	2,50	0857 00	100 stuks	0822 01TL
			Nieuw- zilver	Zilver	1,20	12,00	1,80	0831 00	100 stuks	0822 01TL
			Messing	Goud	1,20	12,00	1,80	0831 10	100 stuks	0822 02TL
			Messing	Gun	1,20	12,00	1,80	0831 20	100 stuks	0822 03
			Nieuw- zilver	Zilver	1,20	12,00	2,50	0841 01	100 stuks	0822 01TL
			Nieuw- zilver	Goud	1,20	12,00	2,50	0841 11	100 stuks	0822 02TL
			Staal	Zilver	1,20	12,60	2,20	0858 00	100 stuks	0831 02
			Staal	Goud	1,20	12,60	2,20	0858 10	100 stuks	0831 12
			Nieuw- zilver	Zilver	1,20	15,00	1,80	0843 00	100 stuks	0822 01TL
			Staal	Zilver	1,40	10,60	2,80	0835 00	100 stuks	0824 01TL
			Staal	Goud	1,40	10,60	2,80	0835 10	100 stuks	0824 02TL
			Nieuw- zilver	Zilver	1,40	12,00	2,50	0841 00	100 stuks	0824 01TL
			Messing	Goud	1,40	12,00	2,50	0841 10	100 stuks	0824 02TL
			Nieuw- zilver	Gun	1,40	12,00	2,50	0841 20	100 stuks	0824 03
			Staal	Zilver	1,40	12,60	2,50	0857 01	100 stuks	0824 01TL
			Staal	Zilver	1,40	12,60	2,20	0858 01	100 stuks	0831 04
			Staal	Goud	1,40	12,60	2,20	0858 11	100 stuks	0831 14
			Nieuw- zilver	Zilver	1,40	15,00	1,80	0843 01	100 stuks	0824 01TL
			Nieuw- zilver	Goud	1,40	15,00	1,80	0843 11	100 stuks	0824 02TL

Speciale schroeven



		Schroef-kop	Materiaal	Kleur				Bestel-nr.		Passende moer
		⊖	Staal	Zilver	1,20	3,40	1,60	0882 00	100 stuks	-
		⊖	Staal	Goud	1,20	3,40	1,60	0882 10	100 stuks	-
		⊖	Staal	Zilver	1,20	7,00	2,00	0883 00	100 stuks	-
		⊖	Staal	Zilver	1,30	3,50	1,70	0880 00	100 stuks	-
		⊖	Staal	Goud	1,30	3,50	1,70	0880 10	100 stuks	-
		⊕	Staal	Zilver	1,40	3,60	2,00	0884 00	100 stuks	-
		⊕	Staal	Zilver	1,40	4,40	2,00	0884 01	100 stuks	-
		⊕	Staal	Zilver	1,40	4,70	2,00	0884 02	100 stuks	-
		⊖	Staal	Zilver	1,60	4,00	2,50	0811 05	50 stuks	-
		⊖	Staal	Zilver	1,60	4,60	2,50	0811 06	50 stuks	-



Speciale schroeven

Torx schroeven

Staal, verkrijgbaar in zilverkleur
in de maten TX2, TX3 en TX4

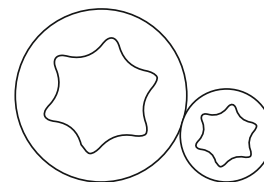

Torx TX2 schroeven

		Schroef- kop	Materiaal	Kleur				Bestel- nr.		Passende moer
			Staal	Zilver	1,00	4,50	1,80	0889 00	100 stuks	-

Torx TX3 schroeven

		Schroef- kop	Materiaal	Kleur				Bestel- nr.		Passende moer
			Staal	Zilver	1,20	3,00	2,00	0886 03	100 stuks	-
			Staal	Zilver	1,20	3,50	2,00	0886 04	100 stuks	-
			Staal	Zilver	1,20	3,90	2,00	0886 00	100 stuks	-
			Staal	Zilver	1,20	4,00	2,00	0886 05	100 stuks	-
			Staal	Zilver	1,20	4,40	2,00	0886 01	100 stuks	-
			Staal	Zilver	1,20	4,90	2,00	0886 02	100 stuks	-

Torx TX4 schroeven

		Schroef- kop	Materiaal	Kleur				Bestel- nr.		Passende moer
			Staal	Zilver	1,40	3,00	2,00	0887 03	100 stuks	-
			Staal	Zilver	1,40	3,50	2,00	0887 04	100 stuks	-
			Staal	Zilver	1,40	3,90	2,00	0887 00	100 stuks	-
			Staal	Zilver	1,40	4,00	2,00	0887 05	100 stuks	-
			Staal	Zilver	1,40	4,40	2,00	0887 01	100 stuks	-
			Staal	Zilver	1,40	4,90	2,00	0887 02	100 stuks	-



Onze Torx schroevendraaiers vindt u op pagina C 9.

Speciale schroeven

Schroeven voor kunststof scharnieren

Staal, verkrijgbaar in de kleuren zilver en gun



Grof schroefdraad speciaal voor kunststoffen

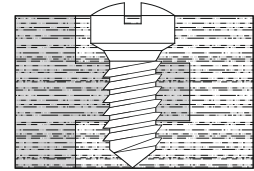

		Schroefkop	Materiaal	Kleur				Bestel-nr.		Passende moer
			Staal	Gun	1,20	3,00	2,30	0833 20	50 stuks	-
			Staal	Zilver	1,40	7,80	2,00	0855 00	50 stuks	-
			Staal	Zilver	1,40	10,80	2,00	0855 01	50 stuks	-
			Staal	Zilver	1,50	5,00	2,00	0855 04	50 stuks	-
			Staal	Zilver	1,60	4,00	2,50	0855 06	50 stuks	-
			Staal	Zilver	1,60	5,20	2,50	0855 07	50 stuks	-
			Staal	Zilver	1,60	6,00	2,50	0855 05	50 stuks	-
			Staal	Zilver	1,60	7,80	2,00	0855 02	50 stuks	-
			Staal	Zilver	1,60	10,80	2,00	0855 03	50 stuks	-

Flexscharnier schroeven

Staal, verkrijgbaar in de kleuren zilver, goud en gun



Eenvoudig inkorten door af te breken



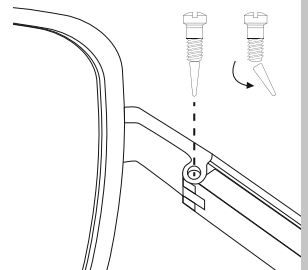

































































Gemakkelijke montage door conische stift



		Schroefkop	Materiaal	Kleur				Bestel-nr.		Passende moer
			Staal	Zilver	1,00	5,80/ 2,80	1,40	0819 05	100 stuks	-
			Staal	Goud	1,00	5,80/ 2,80	1,40	0819 15	100 stuks	-
			Staal	Zilver	1,20	5,90/ 3,50	2,00	0819 03	100 stuks	-
			Staal	Goud	1,20	5,90/ 3,50	2,00	0819 13	100 stuks	-



Speciale schroeven

Flexscharnier schroeven										
		Schroef- kop	Materiaal	Kleur				Bestel- nr.		Passende moer
			Staal	Gun	1,20	5,90/ 3,50	2,00	0819 23	100 stuks	-
			Staal	Zilver	1,20	7,00/ 4,00	2,00	0819 08	100 stuks	-
			Staal	Zilver	1,20	7,50/ 4,50	2,00	0819 09	100 stuks	-
			Staal	Zilver	1,30	6,50/ 3,50	2,00	0819 06	100 stuks	-
			Staal	Goud	1,30	6,50/ 3,50	2,00	0819 16	100 stuks	-
			Staal	Zilver	1,40	6,50/ 3,50	2,00	0819 00	100 stuks	-
			Staal	Zilver	1,40	7,00/ 4,00	2,00	0819 01	100 stuks	-
			Staal	Zilver	1,40	7,80/ 4,80	2,00	0819 02	100 stuks	-
			Staal	Goud	1,40	6,50/ 3,50	2,00	0819 10	100 stuks	-
			Staal	Goud	1,40	7,00/ 4,00	2,00	0819 11	100 stuks	-
			Staal	Goud	1,40	7,80/ 4,80	2,00	0819 12	100 stuks	-
			Staal	Gun	1,40	6,50/ 3,50	2,00	0819 20	100 stuks	-
			Staal	Zilver	1,40	8,50/ 5,50	2,00	0819 010	100 stuks	-
			Staal	Zilver	1,40	9,50/ 6,50	2,00	0819 011	100 stuks	-
			Staal	Zilver	1,40	10,60/ 3,60	1,80	0817 00	100 stuks	-
			Staal	Goud	1,40	10,60/ 3,60	1,80	0817 10	100 stuks	-
			Staal	Gun	1,40	10,60/ 3,60	1,80	0817 20	100 stuks	-
			Staal	Zilver	1,50	6,50/ 3,50	2,00	0819 07	100 stuks	-
			Staal	Goud	1,50	6,50/ 3,50	2,00	0819 17	100 stuks	-
			Staal	Zilver	1,60	6,50/ 3,50	2,00	0819 04	100 stuks	-
			Staal	Goud	1,60	6,50/ 3,50	2,00	0819 14	100 stuks	-

Speciale schroeven

Flexscharnier schroeven met blauwe zekering









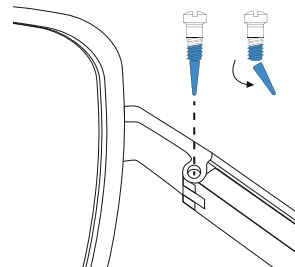













































Staal, verkrijgbaar in de kleuren zilver, goud en gun

Gemakkelijke montage door conische stift

Goede bevestiging door blauwe schroevenlak

Eenvoudig inkorten door af te breken



		Schroefkop	Materiaal	Kleur				Bestel-nr.		Passende moer
			Staal	Zilver	1,00	5,80/ 2,80	1,40	0819 05TL	50 stuks	-
			Staal	Goud	1,00	5,80/ 2,80	1,40	0819 15TL	50 stuks	-
			Staal	Zilver	1,20	5,90/ 3,50	2,00	0819 03TL	50 stuks	-
			Staal	Goud	1,20	5,90/ 3,50	2,00	0819 13TL	50 stuks	-
			Staal	Gun	1,20	5,90/ 3,50	2,00	0819 23TL	50 stuks	-
			Staal	Zilver	1,30	6,50/ 3,50	2,00	0819 06TL	50 stuks	-
			Staal	Goud	1,30	6,50/ 3,50	2,00	0819 16TL	50 stuks	-
			Staal	Zilver	1,40	6,50/ 3,50	2,00	0819 00TL	50 stuks	-
			Staal	Zilver	1,40	7,00/ 4,00	2,00	0819 01TL	50 stuks	-
			Staal	Goud	1,40	6,50/ 3,50	2,00	0819 10TL	50 stuks	-
			Staal	Goud	1,40	7,00/ 4,00	2,00	0819 11TL	50 stuks	-
			Staal	Gun	1,40	6,50/ 3,50	2,00	0819 20TL	50 stuks	-
			Staal	Zilver	1,50	6,50/ 3,50	2,00	0819 07TL	50 stuks	-
			Staal	Goud	1,50	6,50/ 3,50	2,00	0819 17TL	50 stuks	-
			Staal	Zilver	1,60	6,50/ 3,50	2,00	0819 04TL	50 stuks	-
			Staal	Goud	1,60	6,50/ 3,50	2,00	0819 14TL	50 stuks	-



Speciale schroeven

Hilco Logic® schroeven

























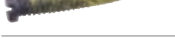





In 1998 vereenvoudigde Hilco optiekreparaties met de Logic® neuspad.

10.000 klanten en 10 miljoen pads later, hebben we Logic® naar de schroef gebracht.

Het Logic® schroefstelsel bevat slechts 6 schroeven in verschillende schroefdraadmaten die alle andere type schroeven in uw voorraad vervangt, inclusief flex en zelftappend.

- Vermindert uw voorraad met 80 %
- Schone breuk op de gewenste lengte
- Zeer geschikt voor flexscharnieren en sluitblokken



		Schroef-kop	Materiaal	Kleur				Bestel-nr.		Passende moer
			Staal	Zilver	1,20	11,60	2,00	0888 00	25 stuks	-
			Staal	Goud	1,20	11,60	2,00	0888 10	25 stuks	-
			Staal	Zwart	1,20	11,60	2,00	0888 20	25 stuks	-
			Staal	Zilver	1,30	11,60	2,00	0888 01	25 stuks	-
			Staal	Goud	1,30	11,60	2,00	0888 11	25 stuks	-
			Staal	Zwart	1,30	11,60	2,00	0888 21	25 stuks	-
			Staal	Zilver	1,40	11,60	2,00	0888 02	25 stuks	-
			Staal	Goud	1,40	11,60	2,00	0888 12	25 stuks	-
			Staal	Zwart	1,40	11,60	2,00	0888 22	25 stuks	-
			Staal	Zilver	1,50	11,60	2,00	0888 03	25 stuks	-
			Staal	Goud	1,50	11,60	2,00	0888 13	25 stuks	-
			Staal	Zwart	1,50	11,60	2,00	0888 23	25 stuks	-
			Staal	Zilver	1,60	11,60	2,00	0888 04	25 stuks	-
			Staal	Goud	1,60	11,60	2,00	0888 14	25 stuks	-
			Staal	Zwart	1,60	11,60	2,00	0888 24	25 stuks	-
			Staal	Zilver	1,80	11,60	2,00	0888 05	25 stuks	-
			Staal	Goud	1,80	11,60	2,00	0888 15	25 stuks	-
			Staal	Zwart	1,80	11,60	2,00	0888 25	25 stuks	-

Schroeven met transparante zekering

Staal, verkrijgbaar in de kleuren zilver en goud

Aangebrachte transparante nylonbeveiliging

Zelftappende schroefdraad

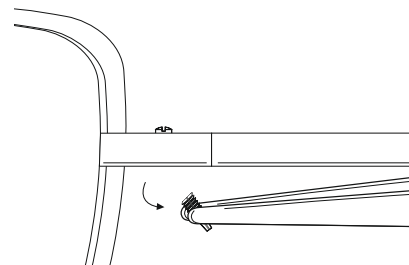









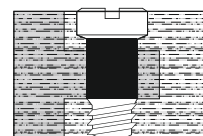



















		Schroefkop	Materiaal	Kleur				Bestel-nr.		Passende moer
			Staal	Zilver	1,30	11,50	1,80	0861 01	50 stuks	-
			Staal	Goud	1,30	11,50	1,80	0861 11	50 stuks	-
			Staal	Zilver	1,40	11,50	1,80	0862 01	50 stuks	-
			Staal	Goud	1,40	11,50	1,80	0862 11	50 stuks	-
			Staal	Zilver	1,50	11,50	1,80	0863 01	50 stuks	-
			Staal	Goud	1,50	11,50	1,80	0863 11	50 stuks	-

Veerschroeven

Staal, verkrijgbaar in zilverkleur

Vlot beweegbare veren, ook bij vast aangetrokken schroeven, door zwarte nylon hulzen



		Schroefkop	Materiaal	Kleur				Bestel-nr.		Passende moer
			Staal	Zilver	1,40	3,00	2,00	0811 00	50 stuks	-
			Staal	Zilver	1,40	3,50	2,00	0811 01	50 stuks	-
			Staal	Zilver	1,40	4,00	2,00	0811 02	50 stuks	-
			Staal	Zilver	1,40	4,50	2,00	0811 03	50 stuks	-
			Staal	Zilver	1,60	3,50	2,50	0811 04	50 stuks	-
			Staal	Zilver	1,60	4,00	2,50	0811 05	50 stuks	-
			Staal	Zilver	1,60	4,60	2,50	0811 06	50 stuks	-



Speciale schroeven

Schroeven met zwarte zekering









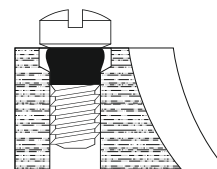





















Goede schroefbevestiging door vastklemmen met behulp van de zwarte borgring



Kruis-/gleufcombinatie voor vrije keuze van de schroevendraaier

Materiaal: staal



		Schroefkop	Materiaal	Kleur				Bestel-nr.		Passende moer
			Staal	Zilver	1,40	2,80	1,80	0851 01	100 stuks	-
			Staal	Zilver	1,40	3,30	2,00	0869 01	100 stuks	-
			Staal	Zilver	1,40	3,40	1,80	0851 02	100 stuks	-
			Staal	Zilver	1,40	3,70	2,00	0869 02	100 stuks	-
			Staal	Zilver	1,40	3,90	2,00	0869 00	100 stuks	-
			Staal	Zilver	1,40	4,00	1,80	0851 03	100 stuks	-
			Staal	Zilver	1,40	4,20	2,00	0869 03	100 stuks	-
			Staal	Zilver	1,40	4,30	1,80	0851 00	100 stuks	-

Schroeven met blauwe Tuflock

Verkrijgbaar in zilverkleur



Meervoudig gebruik mogelijk door de Tuflock-laag, die over de helft van de schroefdraadlengte gesmolten werd

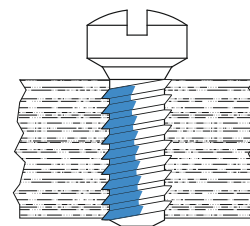

		Functie	Schroefkop	Materiaal	Kleur				Bestel-nr.		Passende moer
				Nieuw-zilver	Zilver	1,00	4,00	1,40	0896 00TL	50 stuks	-
				Staal	Zilver	1,40	6,00	1,80	0860 58TL	50 stuks	-
				Staal	Zilver	1,40	6,50	1,80	0860 30TL	50 stuks	-
				Staal	Zilver	1,50	5,20	1,80	0842 00TL	50 stuks	-
				Staal	Zilver	1,60	5,20	1,80	0842 01TL	50 stuks	-

Schroevenassortiment

Inhoud: 28 verschillende schroeven en moeren (2.800 stuks)

0890 16



Onze onderdelenboxen vindt u op pagina G 12 en G 13.

**U ontvangt de producten met
bijpassende scharnierende klapboxen.
Wijzigingen voorbehouden.**

Schroevenassortiment gunkleuren

Inhoud: 13 verschillende schroeven en moeren (1.300 stuks),
2 lege vakken

0890 17



Schroevenassortiment

In de klapbox Nr. 1457 20 (zie pagina G 14).

Inhoud: 7 soorten (700 stuks) van de meest gangbare schroeven en moeren, 1 leeg vak

0890 10



Glasbrilschroevenassortiment

Inhoud: 12 verschillende schroeven, moeren, glasbrilringen en hulzen (1.300 stuks)

0890 18



U ontvangt de producten met
bijpassende scharnierende klapboxen.
Wijzigingen voorbehouden.

Ringenassortiment

Inhoud: 8 verschillende ringen (1.000 stuks)

0745 50



Strasstenen assortiment

- Achterzijde vlak en conisch in drie maten: S (1,7–1,9 mm), M (2,1–2,3 mm) en L (2,5–2,7 mm)
- Verkrijgbaar in een heldere set en een gekleurde set
- Gekleurd bestaat uit: kristal (helder), roze, lichtblauw en lichtbruin

 55 x 7 x 45 mm

 150 stuks

0900 50 Kristal (helder)

0900 51 Gekleurd



Voor de conische stenen adviseren wij onze kegelfrees Nr. 2265 . . op pagina C 36.































































Strassteen grijper

Het ideale hulpmiddel voor het exact plaatsen van kleine onderdelen, zoals strassteentjes, glasbrilringen, schroeven, enz. Door het afspoelen van het uiteinde met water vernieuwt u de plakkracht.

0900 61























































Moeren

		Vorm	Materiaal	Kleur			Bestel-nr.		Passende moersleutel
			Nieuw-zilver	Zilver	1,10	2,40	0866 00	100 stuks	1746 00
			Nieuw-zilver	Goud	1,10	2,40	0866 10	100 stuks	1746 00
			Nieuw-zilver	Gun	1,10	2,40	0866 20	100 stuks	1746 00
			Nieuw-zilver	Zilver	1,20	2,50	0822 01	100 stuks	1746 00
	 		Nieuw-zilver	Zilver	1,20	2,50	0822 01TL	100 stuks	1746 00
			Messing	Goud	1,20	2,50	0822 02	100 stuks	1746 00
	 		Messing	Goud	1,20	2,50	0822 02TL	100 stuks	1746 00
			Nieuw-zilver	Gun	1,20	2,50	0822 03	100 stuks	1746 00
			Nieuw-zilver	Zilver	1,30	2,50	0823 01	100 stuks	1746 00
			Nieuw-zilver	Gun	1,30	2,50	0823 03	100 stuks	1746 00
			Nieuw-zilver	Zilver	1,40	2,50	0824 01	100 stuks	1746 00
	 		Nieuw-zilver	Zilver	1,40	2,50	0824 01TL	100 stuks	1746 00
			Messing	Goud	1,40	2,50	0824 02	100 stuks	1746 00
	 		Messing	Goud	1,40	2,50	0824 02TL	100 stuks	1746 00
			Nieuw-zilver	Gun	1,40	2,50	0824 03	100 stuks	1746 00
			Nieuw-zilver	Zilver	1,50	2,50	0830 01	100 stuks	1746 00
			Nieuw-zilver	Zilver	1,60	2,60	0833 01	100 stuks	1767 00



Dopmoeren

		Vorm	Materiaal	Kleur			Bestel-nr.		Passende moersleutel
			Nieuw-zilver	Zilver	1,20	2,20	0839 00	100 stuks	1749 00
			Messing	Goud	1,20	2,20	0839 10	100 stuks	1749 00
			Nieuw-zilver	Gun	1,20	2,20	0839 20	100 stuks	1749 00
			Staal	Zilver	1,20	2,40	0832 00	100 stuks	1767 00
			Staal	Goud	1,20	2,40	0832 10	100 stuks	1767 00
			Staal	Zilver	1,20	2,40	0849 00	100 stuks	1767 00
			Staal	Goud	1,20	2,40	0849 10	100 stuks	1767 00
			Nieuw-zilver	Zilver	1,40	2,20	0840 00	100 stuks	1749 00
			Messing	Goud	1,40	2,20	0840 10	100 stuks	1749 00
			Nieuw-zilver	Gun	1,40	2,20	0840 20	100 stuks	1749 00
			Staal	Zilver	1,40	2,40	0838 00	100 stuks	1767 00
			Staal	Goud	1,40	2,40	0838 10	100 stuks	1767 00
			Staal	Zilver	1,40	2,40	0850 00	100 stuks	1767 00
			Staal	Goud	1,40	2,40	0850 10	100 stuks	1767 00
			Staal	Zilver	1,50	2,40	0829 00	100 stuks	1746 00
			Staal	Goud	1,50	2,40	0829 10	100 stuks	1746 00





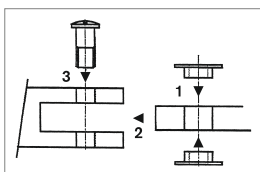































Speciale ringen voor titanium veren

















		Schematisch zijaanzicht	Materiaal	Kleur			Bestel-nr.	
			Staal	Zilver	1,20	2,80	0745 07	100 stuks
			Staal	Zilver	1,40	2,80	0745 08	100 stuks



De ringen vermijden een direct contact tussen scharnier en scharnierrol. De montage volgt in drie stappen volgens bijgaande afbeelding. Eerst worden de ringen aan de veer gezet, daarna wordt de veer in het scharnier gezet en als laatste wordt de schroef vastgezet. Nu bewegen de veren gemakkelijker en slijten ze minder.

Glasbrilringen

		Materiaal	Kleur			Bestel-nr.	
		Nieuwzilver voor schroeven met een conische kop	Zilver	1,20	2,80	0745 10	100 stuks
		Messing voor schroeven met een conische kop	Goud	1,20	2,80	0745 11	100 stuks
		Nieuwzilver	Zilver	1,20	2,50	0745 20	100 stuks
		Nieuwzilver	Goud	1,20	2,50	0745 14	100 stuks
		Nieuwzilver	Gun	1,20	2,50	0745 30	100 stuks
		Plastic	Transparant	1,30	2,60	0745 00	150 stuks
		Nieuwzilver	Zilver	1,30	2,50	0745 21	100 stuks
		Nieuwzilver	Goud	1,30	2,50	0745 15	100 stuks
		Plastic	Transparant	1,40	2,80	0745 02	150 stuks
		Nieuwzilver	Zilver	1,40	2,50	0745 22	100 stuks
		Nieuwzilver	Goud	1,40	2,50	0745 16	100 stuks
		Nieuwzilver	Gun	1,40	2,80	0745 32	100 stuks
		Nieuwzilver voor schroeven met een conische kop	Zilver	1,40	2,80	0745 09	100 stuks
		Messing voor schroeven met een conische kop	Goud	1,40	2,80	0745 12	100 stuks
		Nieuwzilver	Zilver	1,50	2,50	0745 23	100 stuks
		Nieuwzilver	Goud	1,50	2,50	0745 17	100 stuks

Glasbrilringen							
		Materiaal	Kleur			Bestel-nr.	
		Plastic	Transparant	1,60	3,00	0745 13	150 stuks
		Nieuwzilver voor hulsmoeren Nr. 0844 00	Zilver	1,65	2,70	0745 24	100 stuks
		Nieuwzilver voor hulsmoeren Nr. 0844 10	Goud	1,65	2,70	0745 18	100 stuks
		Nieuwzilver voor hulsmoeren Nr. 0845 00	Zilver	1,85	2,90	0745 25	100 stuks
		Nieuwzilver voor hulsmoeren Nr. 0845 10	Goud	1,85	2,90	0745 19	100 stuks
		Plastic	Transparant	2,00	3,50	0745 33	150 stuks



Ons ringenassortiment Nr. 0745 50 vindt u op pagina F 46.

Wigvormige ringen								
		Schematisch zijaanzicht	Materiaal	Kleur			Bestel-nr.	
			Plastic	Transparant	1,20	2,80	0745 26	150 stuks
			Plastic	Transparant	1,40	2,80	0745 27	150 stuks

Hulsmoeren										
		Vorm	Materiaal	Kleur				Bestel-nr.		Passende moersleutel
			Nieuwzilver	Zilver	1,20	4,00	2,50	0844 00	100 stuks	1746 00
			Messing	Goud	1,20	4,00	2,50	0844 10	100 stuks	1746 00
			Nieuwzilver	Zilver	1,40	4,00	2,50	0845 00	100 stuks	1746 00
			Messing	Goud	1,40	4,00	2,50	0845 10	100 stuks	1746 00

Beschermdoppen voor glasbrilschroef								
		Materiaal	Kleur				Bestel-nr.	
		Plastic	Transparant	1,20	2,50	3,50	0771 22	100 stuks
		Plastic	Transparant	1,40	2,50	3,50	0771 23	100 stuks





Premium krimpousen van frey & winkler























- Hoge kwaliteit basismaterialen
- Product gecertificeerd volgens ISO 9001
- Hoge dimensionale precisie
- Geproduceerd met behulp van de nieuwste technologie
- Maximale duurzaamheid
- Kleurstabiliteit
- Zonder uitloop



Hulzen voor glasbrillen

		Materiaal	Kleur	Materiaal kwaliteit			Bestel-nr.	
		Plastic	Transparant	Halfzacht	0,80	1,30	0771 27	50 stuks
		Plastic	Transparant	Halfzacht	0,80	1,40	0771 04	50 stuks
		Plastic	Transparant	Zacht	0,80	1,40	0771 05	50 stuks
		Plastic	Transparant	Halfhard	0,80	1,40	0771 06	50 stuks
		Plastic	Transparant	Zacht open versie	0,80	1,40	0771 10	50 stuks
		Plastic	Transparant	Halfhard open versie	0,80	1,40	0771 11	50 stuks
		Plastic	Transparant	Halfzacht open versie	0,80	1,40	0771 12	50 stuks
		Plastic	Transparant	Halfzacht	0,80	1,50	0771 28	50 stuks
		Plastic	Transparant	Zacht	1,00	1,80	0771 07	50 stuks
		Plastic	Transparant	Halfhard	1,00	1,80	0771 08	50 stuks
		Plastic	Transparant	Halfzacht	1,00	1,80	0771 09	50 stuks

Hulzen voor glasbrillen

		Schematisch zijaanzicht	Materiaal	Kleur	Materiaal kwaliteit			Bestel-nr.	
			Plastic	Transparant		1,20	2,80	0771 13	100 stuks
			Plastic	Transparant		1,40	2,80	0771 14	100 stuks
			Plastic	Transparant	Hard	1,00	1,80	0771 21	50 stuks
			Plastic	Transparant	Hard	0,80	1,50	0771 24	50 stuks
			Plastic	Transparant	Hard	0,80	1,40	0771 25	50 stuks
			Plastic	Transparant	Hard	0,80	1,50	0771 26	50 stuks
			Plastic	Transparant	Zacht	0,80	1,60	0771 30	50 stuks
			Plastic	Transparant	Hard	1,00	1,80	0771 29	50 stuks

Hulzen assortiment

Inhoud: 7 verschillende hulzen voor glasbrillen (350 stuks)

0771 50

 28 g



Scharnieren

Toelichting bij de scharnieren:



Scharnierbreedte



Afstand boringen



Afmetingen (breedte
x diepte of breedte
x hoogte x diepte)



Inclinatie



Frezing tussen ogen
en oogdikte



Schroefdraad



Totale lengte



Verpakking:
stuk of paar



Scharnierlengte



Afbeelding vergroot
(200 %)



Kopdiameter

- Alle afmetingen in mm
- Maatwijzigingen voorbehouden



Scharnieroogradius



Afbeelding origineel
(100 %)



Stiftdiameter



Alle scharnieren met dubbele ogen worden met de passende schroef geleverd.

Soldeerscharnieren

Vorstukdeel links	Vorstukdeel rechts	Veerdeel							Bestel- nr.	
			2,5	0,75–0,75	5,0	1,8	0°	1,4	0400 01	10 stuks
			2,5	0,75–0,75	5,0	1,8	0°	1,4	0400 02	10 stuks
			2,5	1,0	5,0	1,8	0°	1,4	0400 10	10 stuks
			3,0	0,9–0,9	5,0	1,8	0°	1,4	0401 01	10 stuks
			3,0	0,9–0,9	5,0	1,8	0°	1,4	0401 02	10 stuks
			3,0	1,2	5,0	1,8	0°	1,4	0401 10	10 stuks
			3,0	0,9–0,9	5,0	1,6	0°	1,4	0402 01	10 stuks
			3,0	0,9–0,9	5,0	1,6	0°	1,4	0402 02	10 stuks
			3,5	1,0–1,0	3,95	1,6	0°	1,4	0403 01	10 stuks
			3,5	1,0–1,0	3,95	1,6	0°	1,4	0403 02	10 stuks
			3,5	1,05–1,05	5,0	1,8	0°	1,4	0404 01	10 stuks
			3,5	1,05–1,05	5,0	1,8	0°	1,4	0404 02	10 stuks
			3,5	1,4	5,0	1,8	0°	1,4	0404 10	10 stuks

Flexscharnieren Sets								
Vorstukdeel		Veerdeel					Bestel-nr.	
links	rechts							
			3,0	0,8-0,8	0°	1,2	0441 10	5 paar
			3,0	0,8-0,8	0°	1,2		
			3,0	1,3	0°	-		
			3,3	0,9-0,9	6°	1,2	0442 10	5 paar
			3,3	0,9-0,9	6°	1,2		
			3,0	1,3	6°	-		

Binnenwerk voor flexscharnieren							
	Materiaal	Kleur			Bestel-nr.		
	Nieuwzilver	Zilver	0,8	1,4	0443 00	5 stuks	
	Nieuwzilver	Zilver	1,0	1,4	0443 01	5 stuks	
	Nieuwzilver	Zilver	1,2	1,4	0443 02	5 stuks	
	Nieuwzilver	Zilver	1,4	1,4	0443 03	5 stuks	

Assortiment scharnieren























Inhoud: Soldeerscharnieren 0401 .. (elk 10 stuks)
 klinkscharnieren 0406 .. (elk 10 stuks)
 klinkstiften 0904 03 (100 stuks)
 (160 stuks)



















0400 50



Scharnieren

Klinkscharnieren

Vorstukdeel		Veerdeel							Bestel- nr.	
links	rechts	links	rechts							
				3,0	1,0	2,5	6°	1,4	0405 01	10 stuks
				3,0	1,0	2,5	6°	1,4	0405 02	10 stuks
				3,0	0,8-0,8	2,5	6°	1,4	0405 11	10 stuks
				3,0	0,8-0,8	2,5	6°	1,4	0405 12	10 stuks
				3,0	1,2	2,5	0°	1,4	0406 00	10 stuks
				3,0	0,9-0,9	2,5	0°	1,4	0406 11	10 stuks
				3,0	0,9-0,9	2,5	0°	1,4	0406 12	10 stuks
				3,5	1,4	2,5	6°	1,4	0407 01	10 stuks
				3,5	1,4	2,5	6°	1,4	0407 02	10 stuks
				3,5	0,9-0,9	2,5	6°	1,4	0407 11	10 stuks
				3,5	0,9-0,9	2,5	6°	1,4	0407 12	10 stuks
				6,0	0,8-0,8	2,5	6°	1,4	0408 01	10 stuks
				6,0	0,8-0,8	2,5	6°	1,4	0408 02	10 stuks
				6,0	0,8-0,8	2,5	16°	1,4	0408 03	10 stuks
				6,0	0,8-0,8	2,5	6°	1,4	0408 04	10 stuks
				6,0	1,1-0,7-1,1	2,5	6°	1,4	0408 11	10 stuks
				6,0	1,1-0,7-1,1	2,5	6°	1,4	0408 12	10 stuks

Insmeltscharnieren								
Vorstukdeel gewoon	Vorstukdeel						Bestel- nr.	
	links	rechts						
			5,0	1,0	0°	1,4	0409 00	10 stuks
			5,0	1,2	0°	1,4	0412 00	10 stuks
			5,0	1,4	0°	1,4	0414 00	10 stuks
			4,4	1,3	0°	1,4	0416 00	10 stuks
			3,5	1,4	0°	1,4	0417 00	10 stuks
			3,5	1,6	0°	1,4	0418 00	10 stuks
			7,0	1,6	0°	1,4	0422 00	10 stuks
			2,8	0,8-0,8	0°	1,4	0423 01	10 stuks
			2,8	0,8-0,8	0°	1,4	0423 02	10 stuks
			3,3	0,9-0,9	0°	1,4	0424 01	10 stuks
			3,3	0,9-0,9	0°	1,4	0424 02	10 stuks
			4,5	1,0-1,0	0°	1,4	0425 01	10 stuks
			4,5	1,0-1,0	0°	1,4	0425 02	10 stuks

Sluitbakken									
		Materiaal	Kleur	Gebruik			Bestel- nr.		
			Nieuwzilver	Zilver	Voor randdraad 1,80 tot 2,50 mm. Moet na het solderen gezaagd worden, incl. schroeven.	1,40	2,60 x 2,80 x 3,40	0898 01	10 stuks
			Nieuwzilver	Zilver	Voor randdraad 1,80 tot 2,30 mm. Moet na het solderen gezaagd worden, incl. schroeven.	1,40	2,40 x 4,50	0898 02	10 stuks

Klinkstiften								
		Materiaal	Kleur				Bestel- nr.	
		Nieuwzilver	Zilver	25,00	1,70	0,70: 1,70	0906 00	200 stuks
		Nieuwzilver	Zilver	10,00	1,80	1,20	0904 03	100 stuks

Het B&S oortips- en veren assortiment:

- Uitgebreide keuze
- Voor alle toepassingen
- Snel vinden voor eenvoudig bestellen



3 stappen bij bestelling

1. Model en materiaal kiezen
2. Lengte kiezen
3. Kleur en diameter kiezen

Handig om te weten

f&w & De pictogrammen garanderen:









- Hoogwaardige basismaterialen
- Maximale duurzaamheid
- Kleurecht
- Hoogste precisie

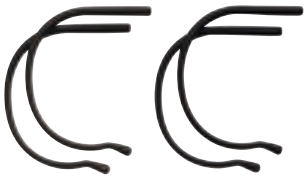

f&w Made in Germany oortips biedt u:

- Ontbreken van spuitpunten voor beter draagcomfort
- Afgeronde kanten
- Hoge dimensionale nauwkeurigheid en hoge kwaliteit van de samengestelde materialen
- Gecertificeerd volgens ISO 9001

Gemakkelijk te vinden in één oogopslag

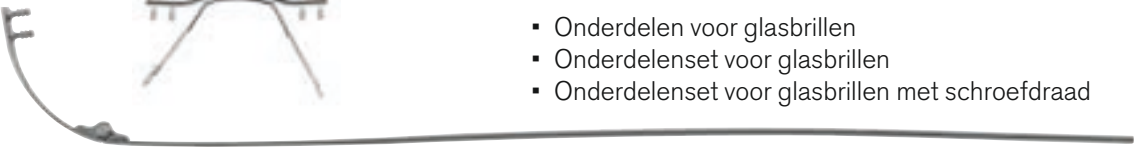
	Standaard oortips	F 60 F 60–F 61 F 62 F 62 F 62
	Siliconen oortips	F 63 F 63 F 63
	Oortips met rechthoekige opening	F 64 F 64 F 64 F 64
	Oortips voor ic! Berlin monturen	F 65 F 65
	Kruloortips	F 66–F 69 F 70 F 70 F 70–F 71
	Windsorringen	F 73 F 73
	Krimpkous	F 74–F 75 F 75
	Lange oortips	F 76 F 76
	Veren	F 77 F 77 F 78–F 79 F 79–F 80
	Onderdelen voor glasbrillen	F 81–F 82 F 81 F 83





Standaard oortips

Lengte: 64 mm

Transparante oortip – kleine opening

Aan het einde gesloten oortip voor hoogwaardige titanium monturen.







	Transparant	f&w	∅ 1,0 mm	0726 27	10 stuks
	Antraciet transparant	f&w	∅ 1,0 mm	0726 28	10 stuks

Lengte: 65 mm

Oortip – klassiek model

	Zwart		∅ 1,45 mm	0712 41	10 stuks
			∅ 1,6 mm	0712 61	10 stuks





Acetaat oortip – dunne type

	Zwart		∅ 1,25 mm	0711 21	10 stuks
			∅ 1,45 mm	0711 41	10 stuks
			∅ 1,6 mm	0711 61	10 stuks
			∅ 1,7 mm	0711 71	10 stuks
			∅ 1,9 mm	0711 91	10 stuks
	Bruin		∅ 1,25 mm	0711 22	10 stuks
			∅ 1,45 mm	0711 42	10 stuks
			∅ 1,6 mm	0711 62	10 stuks
			∅ 1,7 mm	0711 72	10 stuks
			∅ 1,9 mm	0711 92	10 stuks
	Havanna		∅ 1,25 mm	0711 23	10 stuks
			∅ 1,45 mm	0711 43	10 stuks
			∅ 1,6 mm	0711 63	10 stuks
	Transparant		∅ 1,25 mm	0711 24	10 stuks
			∅ 1,45 mm	0711 44	10 stuks
			∅ 1,6 mm	0711 64	10 stuks



Standaard oortips

Lengte: 65 mm

Acetaat oortip – symmetrische vorm

 Zwart	∅ 1,25 mm	0714 21	10 stuks
	∅ 1,45 mm	0714 41	10 stuks
	∅ 1,6 mm	0714 61	10 stuks
	∅ 1,7 mm	0714 71	10 stuks
 Bruin	∅ 1,45 mm	0714 42	10 stuks
	∅ 1,6 mm	0714 62	10 stuks
	∅ 1,7 mm	0714 72	10 stuks
 Havanna	∅ 1,45 mm	0714 43	10 stuks
	∅ 1,6 mm	0714 63	10 stuks
	∅ 1,7 mm	0714 73	10 stuks
 Transparant	∅ 1,45 mm	0714 44	10 stuks
	∅ 1,6 mm	0714 64	10 stuks
	∅ 1,7 mm	0714 74	10 stuks
 Grijs	∅ 1,45 mm	0714 47	10 stuks
	∅ 1,6 mm	0714 67	10 stuks
	∅ 1,7 mm	0714 77	10 stuks

Oortip – symmetrische vorm



 Zwart	∅ 1,2 mm	0709 21	10 stuks
	∅ 1,45 mm	0709 41	10 stuks
	∅ 1,6 mm	0709 61	10 stuks
 Bruin	∅ 1,2 mm	0709 22	10 stuks
	∅ 1,45 mm	0709 42	10 stuks
	∅ 1,6 mm	0709 62	10 stuks
 Havanna	∅ 1,2 mm	0709 23	10 stuks
	∅ 1,45 mm	0709 43	10 stuks
	∅ 1,6 mm	0709 63	10 stuks



Standaard oortips

Lengte: 67 mm

Acetaat oortip – kleine opening



	Zwart	∅ 1,0 mm	0713 01	10 stuks
	Bruin	∅ 1,0 mm	0713 02	10 stuks
	Transparant	∅ 1,0 mm	0713 04	10 stuks

Lengte: 70 mm



Oortip hard

	Transparant	∅ 1,1 mm	0727 27	10 stuks
---	-------------	----------	----------------	----------

Oortip – klassiek model

	Transparant	∅ 1,5 mm	0794 08	10 stuks
	Zwart	∅ 1,5 mm	0794 10	10 stuks
	Donkerbruin	∅ 1,5 mm	0794 16	10 stuks



Oortip – kleine opening

	Zwart	∅ 0,9 mm	0754 01	10 stuks
	Bruin	∅ 0,9 mm	0754 16	10 stuks
	Transparant	∅ 0,9 mm	0754 27	10 stuks

Lengte: 75 mm

Oortip – klassiek model voor verlenging

Voor het verlengen van de veer met minstens 10 mm.

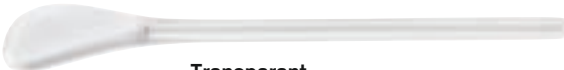

	Zwart	∅ 1,4 mm	0797 10	10 stuks
	Donkerbruin	∅ 1,4 mm	0797 16	10 stuks
	Transparant	∅ 1,4 mm	0797 27	10 stuks

Siliconen oortips

Lengte: 65 mm



Siliconen oortip – kleine opening

Aan één uiteinde gesloten, voor metalen veren van 0,9 tot 1,5 mm, anti-allergisch, eenvoudig aan te brengen met een weinig afwasmiddel.

	Zwart	∅ 0,9 tot 1,5 mm flexibel	0756 01	10 stuks
	Bruin	∅ 0,9 tot 1,5 mm flexibel	0756 16	10 stuks
	Transparant	∅ 0,9 tot 1,5 mm flexibel	0756 27	10 stuks

Lengte: 67 mm

Siliconen oortip – kleine opening

	Zwart	∅ 0,9 tot 1,1 mm flexibel	0716 01	10 stuks
	Bruin	∅ 0,9 tot 1,1 mm flexibel	0716 02	10 stuks
	Transparant	∅ 0,9 tot 1,1 mm flexibel	0716 04	10 stuks

Lengte: 70 mm

Siliconen oortip

	Zwart	 ∅ 1,0 mm	0795 11	10 stuks
		 ∅ 1,4 mm	0795 01	10 stuks
	Donkerbruin	 ∅ 1,0 mm	0795 17	10 stuks
		 ∅ 1,4 mm	0795 07	10 stuks

Oortips met rechthoekige opening





Lengte: 61 mm

Siliconen oortip

		 1,5 x 1,0 mm	0732 01	10 stuks
Zwart				
		 1,5 x 1,0 mm	0732 02	10 stuks
Bruin				
		 1,5 x 1,0 mm	0732 04	10 stuks
Transparant				

Lengte: 63 mm

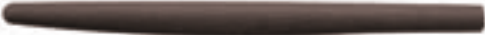
Siliconen oortip voor rechte veren

		 2,6 x 1,5 mm	0715 01	10 stuks
Zwart				
		 2,6 x 1,5 mm	0715 02	10 stuks
Bruin				



Oortip – vlakke vierkante opening

		 4,0 x 1,3 mm	0789 00	10 stuks
Zwart				

Lengte: 70 mm

Oortip – platte opening

Voor smalle veren.

		 2,5 x 1,3 mm	0757 00	10 stuks
Zwart				
		 2,5 x 1,3 mm	0757 01	10 stuks
Bruin				



Lengte: 85 mm

ic! berlin oortip

Materiaal: Thermoplastische elastomeer



Zwart

 2,8 x 1,0 mm

0782 02

2 paar



Grijs

 2,8 x 1,0 mm

0782 03

2 paar

ic! berlin kousenset klein

- Lengte neuskous: 19 mm
- Lengte veerkous: 88 mm
- Diameter veer: 6 mm
- Kleur: Transparant
- Materiaal: Siliconen

0780 01

 5 stuks

ic! berlin kousenset groot

- Lengte neuskous: 13 mm
- Lengte veerkous: 94 mm
- Diameter veer: 10 mm
- Kleur: Transparant
- Materiaal: Siliconen

0780 13

 5 stuks





TIPS & TRICKS

KRULOORTIPS EENVOUDIG MONTEREN

*Zo glijt er niets weg!***Kruloortips**

vb. Bestelnr. 0735 ..

Universele stift

Bestelnr. 2623 01

Kopkniptang

Bestelnr. 1579 79 N

Precisievijl

Bestelnr. 1868 00

Föhn

Bestelnr. 2871 01



ca. 5 minuten

*Zo werkt het***Vorbereitung voor alle kruloortips****1 MARKEREN****2 KNIPPEN****3 VIJLEN**Aanbrengen van de kruloortips bestelnr. 0735 .., 0736 .., 0717 .., 0718 .., 0728 .. en 0749 ... **met verhitting****4 VERWARMEN****5 OPSCHUIVEN****6 AFKOELEN**Aanbrengen van de kruloortips bestelnr. 0731 .. **zonder verhitting****4 KOUD OPSCHUIVEN****5 KLAAR****OPTIONEEL: VAST PERSEN****TIP 1:** Als de veer dunner is dan 1,3 mm, het uiteinde in de bankschroef plat drukken om het te verbreden.**TIP 2:** Kruloortips op plastic veren? Kunststof gedeelte eerst verwijderen om het metaal vrij te maken!

Snij het kunststofgedeelte op 1 cm van het uiteinde los en trek de kunststof van het metaal af.



Siliconen kuloortips

Voor het achteraf aanbrengen op metalen veren en op de metaalkern van kunststof veren.

Metalen veerdikte: ca. 1,3 tot 1,4 mm nodig voor montage

Ø binnen: 1,3 mm
 Ø buiten kinderen: 3,5 mm
 Ø buiten volwassenen: 4,2 mm

0749 . . 1 paar

0731 . . 1 paar

Kinderen: lengte 80 mm		Volwassenen: lengte 95 mm	
Bestelnr.	Kleur	Bestelnr.	Kleur
0749 01	Zwart	0731 01	Zwart
0749 02	Grijs	0731 16	Donkerbruin
0749 03	Petrol		
0749 04	Purper		
0749 05	Rood		
0749 06	Roze		
0749 07	Groen		
0749 10	Geel		
0749 11	Oranje		
0749 12	Lichtblauw		
0749 16	Donkerbruin		
0749 21	Blauw		

Kinderen:

Verbeterde versie, compleet omhuld met siliconen. Polyamide begin en eind zijn niet meer zichtbaar.

Dikte van de siliconenlaag: 0,6 mm

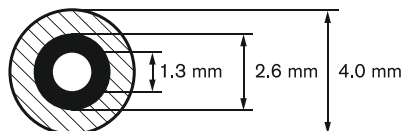

Volwassenen:

Dikte van de siliconenlaag: 0,7 mm

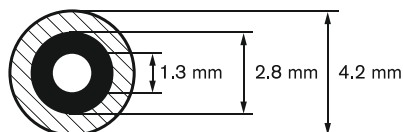

Kunststof

Siliconen

Siliconen kuloortips assortiment

In klapbox systeem.

Inhoud: Elk 2 paar Nr. 0749 06 en 0749 21 en elk 1 paar Nr. 0749 01; 0749 03; 0749 04; 0749 05; 0749 07; 0749 10; 0749 11; 0749 12 en 0749 16 alsmede Nr. 0731 01 en 0731 16
 Wijzigingen voorbehouden.

0749 55 15 paar

Siliconen kuloortips navulassortiment

0749 50 15 paar





Siliconen kuloortips

Voor het achteraf aanbrengen op metalen veren en op de metaalkern van kunststof veren.

Metalen veerdikte: ca. 1,0 tot 1,1 mm nodig voor montage

Ø binnen: 0,9 mm

Ø buiten: 3,4 mm

0717 ..  1 paar

0718 ..  1 paar



„Kuloortips eenvoudig monteren“
(zie pagina F 66)

Dikte van de siliconenlaag: 0,8 mm,
optimale bescherming, optimale bedekking

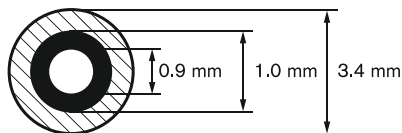

 Kunststof

 Siliconen

Kinderen: lengte 75 mm

Volwassenen: lengte 90 mm

Bestelnr.	Kleur	Bestelnr.	Kleur
0717 01	Zwart	0718 01	Zwart
0717 03	Blauw	0718 03	Blauw
0717 05	Rood	0718 16	Bruin
0717 07	Groen	0718 19	Bordeaux
0717 19	Bordeaux		

Siliconen kuloortips assortiment

In klapbox systeem.

Inhoud: Elk 1 paar Nr. 0717 01; 0717 03; 0717 05; 0717 07 en
0717 19 alsmede Nr. 0718 01; 0718 03; 0718 16 en 0718 19
Wijzigingen voorbehouden.

0717 55  9 paar



Siliconen kuloortips navlassortiment

0717 50  9 paar



De B&S kwaliteitsoortips overtuigen door een kostbare bewerking.
Ze hebben geen ruwe plekken en de bijzonder dikke bedekking zorgt voor een aangenaam draagcomfort.



Siliconen kruloortips

Voor het achteraf aanbrengen op metalen veren en op de metaalkern van kunststof veren.

Metalen veerdikte: ca. 1,4 tot 1,5 mm nodig voor montage

Ø binnen: 1,3 mm

Ø buiten: 3,8 mm

0735 . .  1 paar

0736 . .  1 paar



„Kruloortips eenvoudig monteren“
(zie pagina F 66)

Dikte van de siliconenlaag: 0,8 mm,
optimale bescherming, optimale bedekking

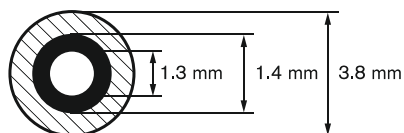

 Kunststof

 Siliconen

Kinderen: lengte 75 mm

Volwassenen: lengte 90 mm

Bestelnr.	Kleur	Bestelnr.	Kleur
0735 01	Zwart	0736 01	Zwart
0735 02	Grijs	0736 02	Grijs
0735 03	Donkerblauw	0736 03	Donkerblauw
0735 04	Lila	0736 05	Rood
0735 05	Rood	0736 16	Bruin
0735 07	Groen	0736 19	Bordeaux
0735 12	Lichtblauw		
0735 16	Bruin		
0735 19	Bordeaux		

Siliconen kruloortips assortiment

In klapbox systeem.

Inhoud: Elk 2 paar Nr. 0735 01; 0735 03; 0735 05; 0735 07; 0735 12
en 0735 19 alsmede elk 3 paar Nr. 0736 01; 0736 02;
0736 03 en 0736 16
Wijzigingen voorbehouden.

0735 70  24 paar

Siliconen kruloortips navulassortiment

0735 65  24 paar



Kruloortips voor volwassenen

Voor het achteraf aanbrengen op metalen veren en op de metaalkern van kunststof veren.

Metalen veerdikte: ca. 1,4 tot 1,5 mm nodig voor montage

Ø binnen: 1,3 mm

Ø buiten: 3,0 mm

Lengte: 90 mm

0728 01 Zwart

 1 paar

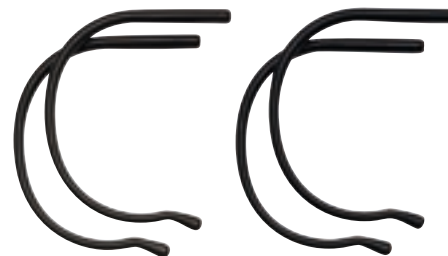

zonder siliconenlaag

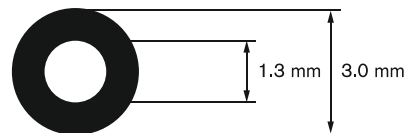

 Kunststof



„Kruloortips eenvoudig monteren“
(zie pagina F 66)



Let op onze PlastiDip – de multifunctionele rubberen coating op pagina E 23.



Bekijk ook eens onze krimpkous op pagina F 75.

MEGALOCK Oortips

Siliconen, aan te brengen op kunststof- en metalen veren, sterke grip.

Ø binnen: 5,9 x 2,7 mm

8903 0 .  10 paar

8903 5 .  50 paar

8903 01 Zwart

8903 51 Zwart

8903 02 Transparant

8903 52 Transparant



Oortips, Antislip

Gelijkend op Nr. 8903 . ., maar grootverpakking, enkel gesorteerd.

Ø binnen: 5,9 x 2,7 mm

0729 1 .  20 stuks

0729 . .  100 stuks

0729 10 Transparant

0729 00 Transparant

0729 11 Zwart

0729 01 Zwart



* Extra kleine opening
voor dunne veren

Ø binnen: 2,8 x 1,8 mm

0729 1 .  20 stuks

0729 . .  100 stuks

0729 12* Transparant

0729 02* Transparant

0729 13* Zwart

0729 03* Zwart



Anti-slip oortips voor kinderen

Materiaal: Thermoplastische elastomeer

Ø binnen: 5,5 x 3,0 mm

0720 0 .  20 stuks

0720 01 Zwart

0720 02 Blauw

0720 03 Roze

0720 50 Assortiment

 60 stuks (elk 20 stuks per kleur)



Anti-slip oortips voor kinderen

Siliconen, schuifbaar op kunststof- en metalen veren, stevige grip.

Passend op onze **Milo & Me** monturen.

Ø binnen: 5,9 x 2,7 mm

85000 . .  5 paar

Bestelnr.	Kleur	Bestelnr.	Kleur
85000 00	Zwart	85000 15	Geelgroen
85000 01	Donkerblauw	85000 16	Denimblauw
85000 02	Blauw	85000 17	Licht grijsblauw
85000 03	Middelblauw	85000 18	Lichtgrijs
85000 04	Lichtblauw	85000 19	Lichtbruin
85000 05	Lichtturquoise	85000 20	Lichtgroen
85000 06	Donkergroen	85000 21	Licht grijsgroen
85000 07	Appelgroen	85000 22	Licht salie
85000 08	Braam	85000 23	Licht braam
85000 09	Rood	85000 24	Lila
85000 10	Lichtpaars	85000 25	Perzik
85000 11	Roze	85000 26	Oranje
85000 12	Donkeraquamarijn	85000 27	Wit
85000 14	Olijfgroen	85000 28	Izig grijs





Windsorringen

De windsorring wordt om de montuurrand gelegd en eventueel gelijmd
Materiaal: Acetaat

Ø binnen: 1,8 x 0,8 mm

0776 ..  2 stuks

0776 00 Kastanje

0776 01 Havana

0776 02 Donkerbruin havanna

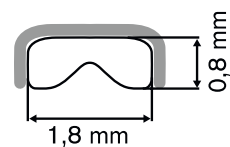

Ø binnen: 2,0 x 1,0 mm

0777 ..  2 stuks

0777 00 Kastanje

0777 01 Havana

0777 02 Donkerbruin havanna

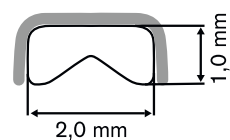

Windsorringen W-profiel

De Windsor ring wordt in de groef geplaatst en eventueel gelijmd.
Materiaal: Acetaat
Ø buiten: 1,8 x 0,8 mm
Kleur: Havana

0751 01  2 stuks

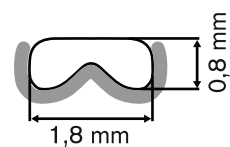

Onze bijpassende windsorringtang 1580 00N op pagina B 29 vereenvoudigt de aanpassing aan brug en bak.





TIPS & TRICKS

KRIMPKOUS

Discrete bescherming voor veren en Co.

Krimpkaus assortiment

Bestelnr. 0786 50

Kleine schaar

Bestelnr. 1614 00

Ultrasoon OPTOSONIC

Bestelnr. 2977 00

Föhn OPTIMONSUN

Bestelnr. 2866 ..



ca. 3 minuten



Zo werkt het

1 REINIGEN



2 BUIGEN



3 VERWIJDEREN



4 KIEZEN

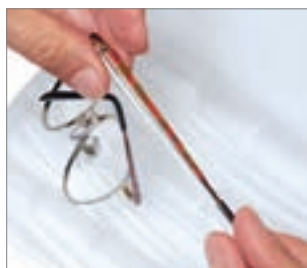

5 INKORTEN



6 KRIMPEN



Krimpkaus

Voor een hoger draagcomfort, tegen nikkellallergie, bijzonder transparant
Materiaal: PE

0786 . .  3 x 1 m

Bestelnr.	Ø binnen	Ø na krimpen
0786 03	1,5 mm	ca. 0,75 mm
0786 05	3,0 mm	ca. 1,50 mm
0786 08	5,0 mm	ca. 2,50 mm
0786 10	7,0 mm	ca. 3,50 mm



Krimpkaus assortiment

Praktische assortimentbox met 4 diameters krimpkaus:

6 x 18 cm diameter 1,5 en 1,7 mm

8 x 18 cm diameter 3,0 en 5,0 mm

Materiaal: PE

0786 50

Krimpkaus

Krimptemperatuur: 120 °C

Ø binnen: 3,2 mm

Ø na krimpen: 1,5 tot 1,6 mm

0784 . .  3 x 1 m

0784 50	Wit	0784 55	Zwart
0784 51	Transparant	0784 56	Grijs
0784 52	Rood	0784 57	Groen
0784 53	Blauw	0784 59	Bruin
0784 54	Geel		

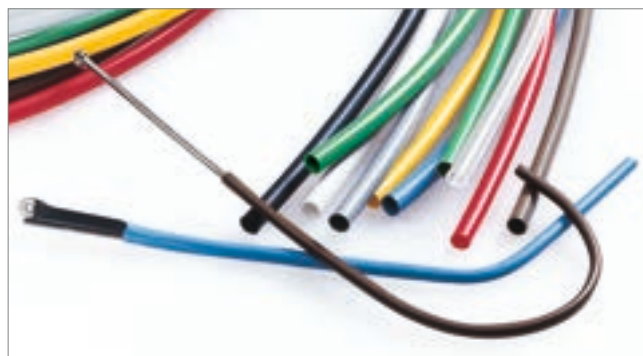

Krimpkaus

Krimptemperatuur: 160 tot 170 °C

Ø binnen: 1,6 mm

Ø na krimpen: 0,8 mm

0785 5 .  3 x 1 m

0785 51 Transparant **0785 55** Zwart

Krimpkaus assortiment

Als Nr. 0784 . . , maar gesorteerd op kleur.

0784 33  10 stuks a 1 m

Krimpkaus oortip assortiment

Lengte: 80 mm, 1 uiteinde gesloten.

Kleur: Zwart

Krimptemperatuur: 150 °C

Ø binnen: 3,0 mm

Ø na krimpen: 1,5 mm

0734 01  10 paar



Krimpkaus – bijzonder transparant

Voor alle metalen en kunststof veren. Speciaal tegen nikkellallergie.

Vlakke breedte: 8,0 mm

Ø binnen: 5,1 mm

Ø na krimpen: ca. 2,8 mm

0787 08  3 x 1 m





Lange oortips

Lengte: 135 mm

Acetaat oortip – extra dun

				
		∅ 1,0 mm	0707 01	10 stuks
Zwart		∅ 1,2 mm	0707 21	10 stuks

Acetaat oortip – symmetrische vorm

				
		∅ 1,2 mm	0708 21	10 stuks
Zwart		∅ 1,45 mm	0708 41	10 stuks
				
		∅ 1,2 mm	0708 22	10 stuks
Bruin		∅ 1,45 mm	0708 42	10 stuks
				
		∅ 1,2 mm	0708 23	10 stuks
Havanna		∅ 1,45 mm	0708 43	10 stuks

Oortips assortiment











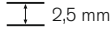

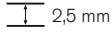

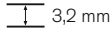

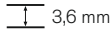

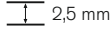

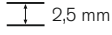

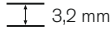

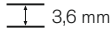

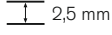

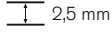

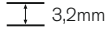

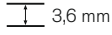
Inhoud: 10 hoogwaardige, moderne oortips in een praktisch klapboxsysteem
Wijzigingen voorbehouden.

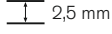
0790 01

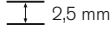
 100 stuks

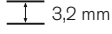

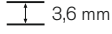









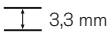

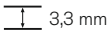

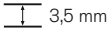

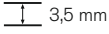

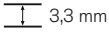
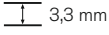

Standaard veren – nikkelvrij – lengte 140 mm

	 2,5 mm	 0,8 mm	1038 00	1 paar
	 2,5 mm	 1,0 mm	1043 00	1 paar
	 3,2 mm	 1,2 mm	1045 00	1 paar
	 3,6 mm	 1,4 mm	1046 00	1 paar
	 2,5 mm	 0,8 mm	1038 01	1 paar
	 2,5 mm	 1,0 mm	1043 01	1 paar
	 3,2 mm	 1,2 mm	1045 01	1 paar
	 3,6 mm	 1,4 mm	1046 01	1 paar
	 2,5 mm	 0,8 mm	1038 02	1 paar
	 2,5 mm	 1,0 mm	1043 02	1 paar
	 3,2 mm	 1,2 mm	1045 02	1 paar
	 3,6 mm	 1,4 mm	1046 02	1 paar
	 2,5 mm	 0,8 mm	1038 03	1 paar
	 2,5 mm	 1,0 mm	1043 03	1 paar
	 3,2 mm	 1,2 mm	1045 03	1 paar
	 3,6 mm	 1,4 mm	1046 03	1 paar

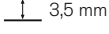
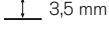
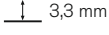
Veren met RAL-scharnieroog – lengte 145 mm



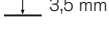







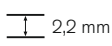

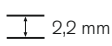

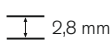

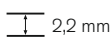

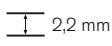

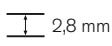

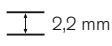

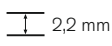
	 1,3 mm	 0,95 mm	1054 11	1 paar
			1054 12	1 paar
			1054 13	1 paar

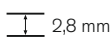
Veren met flexscharnier – nikkelvrij – lengte 140 mm

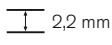

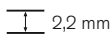

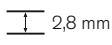

Goud		3,3 mm		0,8 mm	1039 00	1 paar
		3,3 mm		1,0 mm	1040 00	1 paar
		3,5 mm		1,2 mm	1041 00	1 paar
		3,5 mm		1,4 mm	1042 00	1 paar
Zilver		3,3 mm		0,8 mm	1039 01	1 paar
		3,3 mm		1,0 mm	1040 01	1 paar
		3,5 mm		1,2 mm	1041 01	1 paar
		3,5 mm		1,4 mm	1042 01	1 paar
Zwart		3,3 mm		0,8 mm	1039 02	1 paar
		3,3 mm		1,0 mm	1040 02	1 paar
		3,5 mm		1,2 mm	1041 02	1 paar
		3,5 mm		1,4 mm	1042 02	1 paar
Gun		3,3 mm		0,8 mm	1039 03	1 paar
		3,3 mm		1,0 mm	1040 03	1 paar
		3,5 mm		1,2 mm	1041 03	1 paar
		3,5 mm		1,4 mm	1042 03	1 paar

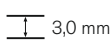

Veren met flexscharnier – nikkelvrij – lengte 140 mm

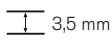

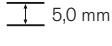
		 2,2 mm	 0,8 mm	1027 00	1 paar
	Goud	 2,2 mm	 1,0 mm	1028 00	1 paar
		 2,8 mm	 1,2 mm	1029 00	1 paar
		 2,2 mm	 0,8 mm	1027 01	1 paar
	Zilver	 2,2 mm	 1,0 mm	1028 01	1 paar
		 2,8 mm	 1,2 mm	1029 01	1 paar
		 2,2 mm	 0,8 mm	1027 02	1 paar
	Zwart	 2,2 mm	 1,0 mm	1028 02	1 paar
		 2,8 mm	 1,2 mm	1029 02	1 paar
		 2,2 mm	 0,8 mm	1027 03	1 paar
	Gun	 2,2 mm	 1,0 mm	1028 03	1 paar
		 2,8 mm	 1,2 mm	1029 03	1 paar

Acetaatveren – lengte 140 mm

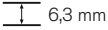

	Zwart	 3,0 mm	 1,0 mm	1047 00	1 paar
	Donkerhavanna			1047 02	1 paar
	Zwart	 3,5 mm	 1,0 mm	1048 00	1 paar
	Donkerhavanna			1048 02	1 paar
	Zwart	 5,0 mm	 1,2 mm	1049 00	1 paar
	Donkerhavanna			1049 02	1 paar

Acetaatveren – lengte 140 mm





Zwart	 6,3 mm	 1,2 mm	1050 00	1 paar
Transparant			1050 01	1 paar
Donkerhavanna			1050 02	1 paar
Lichthavanna			1050 03	1 paar





Zwart	 9,0 mm	 1,2 mm	1051 00	1 paar
Transparant			1051 01	1 paar
Donkerhavanna			1051 02	1 paar
Lichthavanna			1051 03	1 paar



Zwart	 10,0 mm	 1,4 mm	1052 00	1 paar
Transparant			1052 01	1 paar
Donkerhavanna			1052 02	1 paar
Lichthavanna			1052 03	1 paar

Brug voor glasbrillen

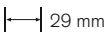
- Materiaal: Edelstaal
- Voor hulzen met een binnenboring van 0,8 mm

1055 ..  29 mm  ca. 17 mm

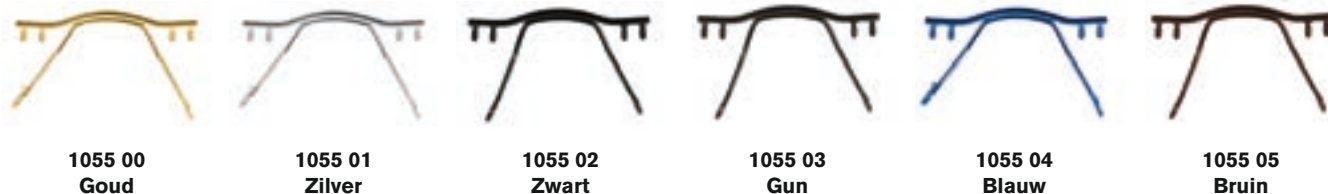

Veer met hoekstuk voor glasbrillen – lengte 140 mm

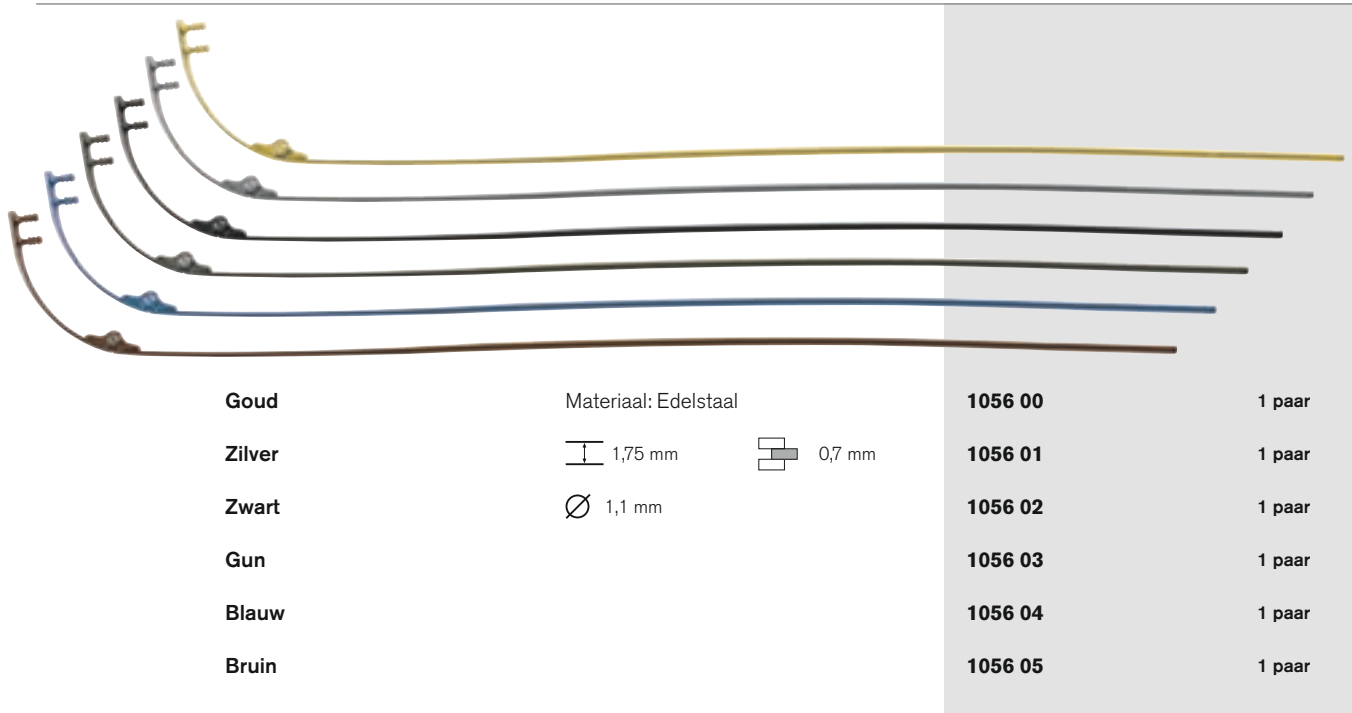

Onderdelenset brug en veer voor glasbrillen



- Materiaal: Edelstaal
- Voor hulzen met binnendiameter van 0,8 mm
- Inclusief: 2 oortips (Nr. 0727 27), 2 neuspads (Nr. 0271 11) en 6 hulzen (Nr. 0771 05)

1058 ..

1058 00 Goud
1058 01 Zilver
1058 02 Zwart
1058 03 Gun
1058 04 Blauw
1058 05 Bruin

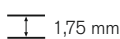

Veer met hoekstuk

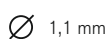
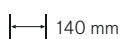
 1,75 mm  0,7 mm  1,1 mm  140 mm

Brug

 29 mm  ca. 17 mm



Monoblock veer voor glasbrillen – lengte 140 mm

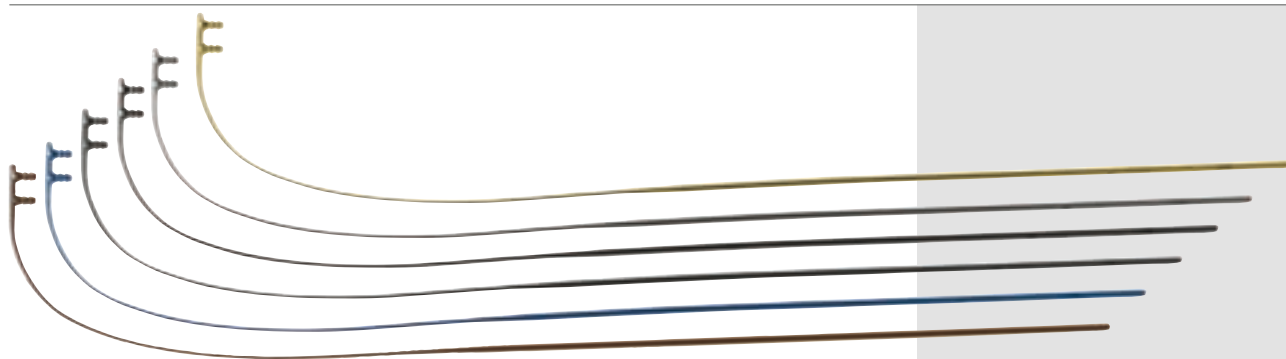

Goud	Materiaal: Edelstaal	1057 00	1 paar
Zilver	 1,6 mm \varnothing 1,0 mm	1057 01	1 paar
Zwart		1057 02	1 paar
Gun		1057 03	1 paar
Blauw		1057 04	1 paar
Bruin		1057 05	1 paar

Onderdelenset monoblock veer voor glasbrillen

- Materiaal: Edelstaal
- Voor hulzen met binnendiameter van 0,8 mm
- Inclusief: 2 oortips (Nr. 0713 01), 2 neuspads (Nr. 0271 11) en 6 hulzen (Nr. 0771 05)

1059 ..

1059 00	Goud
1059 01	Zilver
1059 02	Zwart
1059 03	Gun
1059 04	Blauw
1059 05	Bruin

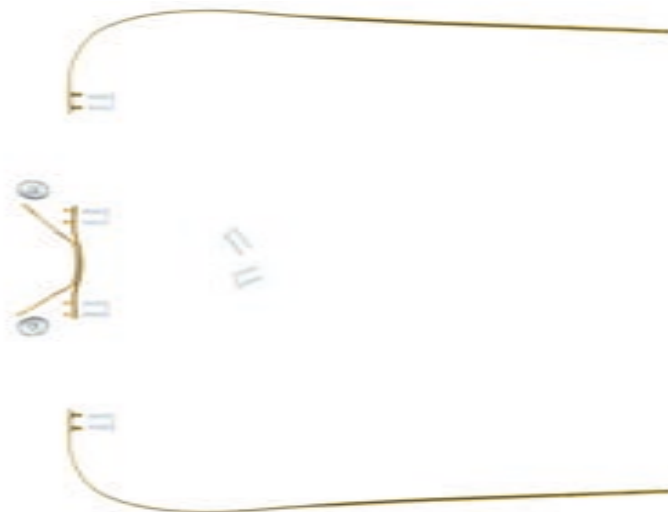

Monoblock veren



 1,6 mm \varnothing 1,0 mm  140 mm

Brug

 29 mm  ca. 17 mm

Neusbrug voor glasbrillen met schroefdraad

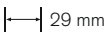
- Materiaal: Edelstaal
- Schroefdraad: 1,4 mm

1065 ..  29 mm  ca. 18 mm



1065 00
Goud

1065 01
Zilver

1065 02
Zwart

1065 03
Gun

1065 04
Blauw

1065 05
Bruin

Glasbrilveer met schroefdraad – lengte 145 mm



Goud

Zilver

Zwart

Gun

Blauw

Bruin

Materiaal: Edelstaal

 1,0 mm  1,4 mm

1066 00

1066 01

1066 02

1066 03

1066 04

1066 05

1 paar

1 paar

1 paar

1 paar

1 paar

1 paar



TENAX strips

- Voor het plakken in de montuurrand
- Lengte: 50 mm, breedte: 3 mm



0733 01

± 0,2 mm

2 vellen à 36 strips



Inlegrand – zelfklevend

- Voor het plakken in de montuurrand
- Breedte: 1,7 mm
- Kleur: Transparant



0733 00

± 0,1 mm 16 m

Inlegrand – Acetaat

- Kleur: Transparant



0743 10

± 1,2 mm ca. 3 m

Inlegrand – CYREX

- Handgemaakte inlegrand met V facet voor optimaal gebruik
- Kleur: Transparant



0743 30 ± 1,4 mm 3,5 m

0743 35 ± 1,4 mm 12 x 3,5 m



Onze hypo tube cement Nr. 3177 00 vindt u op pagina E 13.

Inlegrand – PVC

- Kleur: Transparant



0750 00 ± 1,6 mm 6 m

0750 10 ± 1,6 mm 10 x 6 m

0752 00 ± 1,2 mm 6 m

0752 10 ± 1,2 mm 10 x 6 m

Glasring

Scheurbestendig (> 300 %) en hoge treksterkte tegen verbrassing.



- Materiaal: Siliconen
- Kleur: Transparant

1371 00 ∅ 26 mm ± 0,85 mm 10 stuks

1371 10 ∅ 27 mm ± 0,5 mm 10 stuks



Intrekband

1368 00  5,0 mm  10 m



Nylordraad

∅ 0,5 mm  20 cm

1370 00 Melkwit  100 stuks



Nylordraad – transparant

1370 02 ∅ 0,5 mm  20 m



Nylor-set, 5 spoelen

Inhoud: Nylorinlegdraad-8 profiel 0,51 mm en 0,55 mm, Nylorinlegdraad T-profiel 1,3 mm, Nylordraad 0,50 en 0,60 mm

1369 55

Nylordraad

• Kleur: Transparant

1369 2 .

1369 20 ∅ 0,40 mm  20 m

1369 21 ∅ 0,50 mm  20 m

1369 23 ∅ 0,60 mm  20 m



Nylor inlegdraad 8-profiel

- Voor metalen monturen
- Kleur: Transparant

1369 0 .

1369 00  0,51 mm  10 m



1369 01  0,55 mm  10 m

Nylor inlegdraad T-profiel

- Voor kunststof en metalen monturen
- Kleur: Transparant

1369 1 .

1369 10  1,3 mm  5 m

1369 11  2,0 mm  5 m

Nylor inlegdraad 8-profiel

- Voor metalen monturen

1367 00  0,55 mm  2 m



Onze nylorinlegdraad instrument Nr. 1365 00 en onze nylordraadhaak Nr. 1719 00 vindt u op pagina C 26 en C 27.



Kitplaatjes – Acetaat



0742 00  0,36 mm  100 stuks



Acetaatplaten

• Kleur: Transparant

 130 x 80 mm

0744 00  0,5 mm  3 stuks

0744 10  1,0 mm  3 stuks



Acetaatplaten

Uit dit materiaal kan een volledig montuur gemaakt worden. De set wordt compleet geleverd met ingetrokken ruwe veren en 2 passende insmeltscharnieren.



Kleurwijzigingen voorbehouden.

0744 20  150 x 8 x 65 mm



Acetaatmateriaal

Voor het maken van allerlei oefenstukken.

0744 . .  150 x 6 x 65 mm  2 stuks

eenlaags

0744 31 Havanna **0744 33** Blauw

0744 32 Zwart **0744 34** Transparant



tweelaags

0744 50 Zwart/Rood

0744 51 Donkerblauw/Transparant



drielaags

0744 60 Rood/Wit/Rookgrijs

0744 61 Bruin/Wit/Transparantblauw



Ooglidsteun

Voor solderen of schroeven.

0295 00



Randdraad

Halfrond, glad.

1361 02



1 m



Soldeer montageset, compleet

Voor het maken van een compleet metalen montuur met neussteunen en krulveren.
Randdraad is voorberekt en gevormd.
Wijzigingen in de samenstelling voorbehouden.

1353 00



Soldeer montageset, voorstuk

Inhoud: Randdraad, neussteun, padsteunen, pads, scharnieren, zadelpad
Randdraad is voorberekt en gevormd.
Wijzigingen in de samenstelling voorbehouden.

1354 03



Plat draad

- Voor soldeeroefeningen
- Materiaal: Nieuwzilver

1362 01

4 x 1 mm 1 m



Rond draad

- Voor soldeeroefeningen
- Materiaal: Nieuwzilver

1363 01

1,5 mm 1 m





B&S QUALITY MADE

Auftragsnummer: _____

Name: _____ Telefon: _____ Datum: _____
 Anschrift: _____ E-Mail: _____

Bestellnr.	Gr.	Achse	Art	Werk	Sp.	Gr.	Achse	Art	Werk	Sp.	Gr.	Achse	Art	Werk

R  **L** 

Verordnungsart: Einseitig Beidseitig Folgebefugnis

Verordnung: Einseitig Beidseitig Folgebefugnis

Verordnungsart: Einseitig Beidseitig Folgebefugnis

Verordnung: Einseitig Beidseitig Folgebefugnis

Verordnungsart: Einseitig Beidseitig Folgebefugnis

Verordnung: Einseitig Beidseitig Folgebefugnis

Verordnungsart: Einseitig Beidseitig Folgebefugnis

Verordnung: Einseitig Beidseitig Folgebefugnis



Auftragsnummer: _____

Name: 1041 _____
 Anschrift: _____
 Telefon: _____
 E-Mail: _____

F	R	SpH	
	L	-8.0	-1.0
N	R	-8.5	-1.0
	L		
R	R		
	L		

Werkstatthinweise (z.B. Facette poliert, bes.)

- Regal aufarbeiten

Brillenfassung: Brillenfassung

Gläser /	F
KL	N

LL Verordnungsart, Refraktion:

Notizen: ! Regal abbrechen





OPBERGSYSTEMEN

voor een effectief behandelplan



- G 2 Presenteerblad
- G 3 Orderhoezen
- G 5 Prijsetiketten
- G 6 Werkbakken
- G 10 Onderdelenbakken en klapboxen
- G 14 Cosmetica spiegels



Presenteerblad

- Voor een waardevolle presentatie van uw producten: bijv. brillen, etui's en andere handelsartikelen
- Geborsteld stabiel kunststof blad met anti-slip inleg van zachte polymeer
- Werkbaar oppervlak: 247 x 208 mm
- Zonder inhoud

 300 x 221 x 21 mm

1433 . .

1433 10 Zwart/Lichtgrijs

1433 11 Zwart/Donkergrijs

1433 12 Zwart/Bordeaux



Presentatiebox

- Voor 4 monturen
- Aluminium met transparant deksel voor een snel overzicht
- Zonder inhoud

 200 x 160 x 55 mm

0143 00



Opdracht- en werkmap

- De mappen van duurzame, semi transparante PP-folie
- De vouwbare zijden van hoogwaardig Oxford nylon kunnen tot 4 cm gerekt worden

DIN A5

 155 x 215 x 40 mm  25 stuks

1434 0 .



1434 00 Groen

1434 01 Blauw

1434 02 Rood



DIN A6

 125 x 165 x 40 mm  25 stuks

1434 1 .

1434 10 Groen

1434 11 Blauw

1434 12 Rood



Opdrachtmappen voor contactlenzen

- PVC materiaal met klittenbandsluiting
- Geschikt voor 2 dag- of 4 maandlensverpakkingen
- Opdrachtmaat: 215 x 160 mm
- Maat verpakking: 160 x 110 x 40 mm

 20 stuks

1431 10



Orderhoezen met rits

- Geschikt voor A5 werkbladen
- Inhoud door transparante PE goed te zien en beschermd
- Stabiel en flexibel
- Eenvoudig te openen door ritssluiting
- Zorgt voor een goede organisatie in de werkplaats omdat montuur, glas en order bijeen blijven
- Zo kunnen orders ook extern verzonden worden

 175 x 230 mm

 20 stuks

1436 00



Opdracht- en werkmap opticover

- Geschikt voor A5 werkbladen
- Inhoud direct zichtbaar door transparant pvc materiaal
- Zowel stabiel als flexibel
- Eenvoudig te openen
- Afgeronde hoeken
- Montuur, glas en opdracht- en werkgegevens in een map

 157 x 218 mm

1442 00  20 stuks

1442 10  100 stuks



Schuimrubberinleg voor laden

Voor monturen, snijdbaar

- Buitenmaten: (B x H x D): 197 x 3,4 x 100 cm
- Binnenmaten: (H x D): 25/20 x 44 mm – afgeschuind

1430 10 Donkergrijs



Voor zonnebrillen, snijdbaar

- Buitenmaten: (B x H x D): 197 x 4 x 100 cm
- Binnenmaten: (H x D): 32/20 x 60 mm – afgeschuind

1430 11 Donkergrijs



Prijsetiketten

- Beschrijfbaar prijsetiketten voor bijna alle brillmonturen
- Voor opschuiven aan de brilveer
- Te gebruiken met:
 1. Foliestift (reinigen met spiritus)
 2. Plaketiketten Nr. 0081 00

stabiele vorm

500 stuks

0080 01

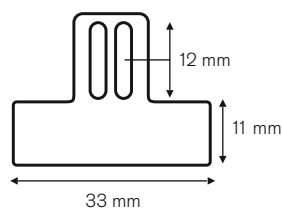

flexibel

elk 200 stuks

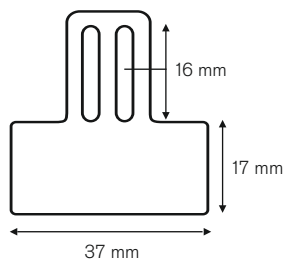

0083 00

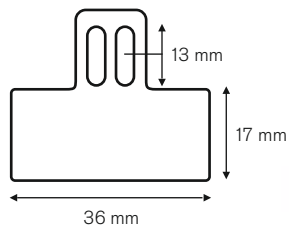

0083 10

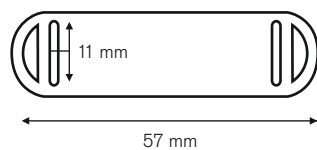

0083 40

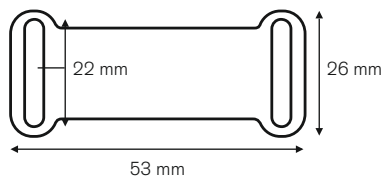

0083 60



Zelfklevende labels

- Passend op alle B & S etiketten
- Wit papier

65 x 10 mm, halveerbaar

264 stuks

0081 00



Werkbakken van topkwaliteit.

De B & S werkbakken worden met CNC gestuurde hightech spuitgietmachines in Europa gemaakt.

De toegepaste productietechniek garandeert een hoge maatnauwkeurigheid en verwerkingskwaliteit. Naast de beproefde standaardmaat hebben we op basis van grote navraag een extra hoge variant voor sportbrillen en zonnebrillen met hoge curves en hun etuis in ons programma opgenomen.

Werkbakken – grote uitvoering

- Flexibel, onbreekbaar ABS kunststof
- Stapelbaar
- Met etikettenhouder en handgreep
- Beide werkbakken kunnen worden gecombineerd

Gekleurd



- Afm. binnenkant (B x H x D): 166 x 45 x 230 mm

Transparant – extra hoog – 65 mm

- Voor brillen met hoge curves
- Afm. binnenkant (B x H x D): 166 x 65 x 230 mm



 170 x 47 x 255 mm  10 stuks met etiketten

 170 x 67 x 255 mm  10 stuks met etiketten

1454 ..

1454 30 Transparant

1454 31 Lichtblauw

1454 32 Rood

1454 33 Grijs

1452 30

Transparant

Etiketten nabestellen

- Eenzijdige folie (herschrijfbaar)

 10 stuks

0077 00 Voor Nr. 1452 30 en 1454 ..

Siliconen inleg

- Voor werkbakken Nr. 1452 .. en 1454 ..
- Materiaal: thermoplastische elastomeer
- Met indeling voor glazen en onderdelen
- Geïntegreerde verdieping om glazen eenvoudig uit te nemen
- Kleuren kunnen een order prioriteit aangeven
- Beschermd tegen krassen en afsplinteren

 163 x 226 mm

 10 stuks

1454 ..

1454 40 Groen

1454 41 Blauw

1454 42 Rood



Werkbakken

- Plaatsbesparend, bij levering eenmalig uit te klappen
- Stapelbaar
- Met aparte indeling voor glazen en onderdelen
- Etikettenhouder aan beide zijden
- Ook voor brillen met een hoge curve
- Materiaal: polypropyleen
- Afm. binnenkant (B x H x D): 160 x 60 x 246 mm

 174 x 67 x 260 mm

 10 stuks met etiketten

1448 3 ..

1448 30 Transparantmat

1448 31 Groenmat

1448 32 Lichtblauwmat

1448 33 Lilamat

1448 34 Pinkmat



Etiketten nabestellen

- Eenzijdige folie (herschrijfbaar)

 10 stuks

0076 00 Voor Nr. 1448 ..

Alle werkbakken zijn stapelbaar, en zijn voorzien van etikettenhouder en handgreep.

Werkbakken van gerecycled kunststof

- Beide werkbakken kunnen worden gecombineerd

Middelgrote uitvoering

- **Extra hoog – 65 mm**
 - Met afzonderlijke indeling voor glazen en onderdelen
 - Afm. binnenkant (B x H x D): 162 x 65 x 255 mm
- Hiernaast vindt u de geschikte metalen drager voor hogere werkbakken
Nr. 1479 01.

 170 x 70 x 262 mm  10 stuks met etiketten

1447 27 Transparant



Middelgrote uitvoering

- Met afzonderlijke indeling voor glazen en onderdelen
 - Afm. binnenkant (B x H x D): 162 x 43 x 255 mm
- Hiernaast vindt u de geschikte metalen drager voor hogere werkbakken
Nr. 1479 00.

 170 x 48 x 262 mm  10 stuks met etiketten

1456 05 Rood



1456 27 Transparant

1456 28 Rookglas



Schuimrubberen inleg

- Voor werkbakken met indeling Nr. 1447 27 en 1456 . .
- Eenvoudig oppakken van glazen zelfs met korte- of kunstnagels
- Beschermt tegen afsplinteren
- Kleur: Antraciet

 80 x 10 x 80 mm  20 stuks

1456 30



Metalen drager voor werkbakken middelgrote uitvoering

- Voor het opslaan van 10 (48 mm hoge) resp. 8 (70 mm hoge) werkbakken
- Een volledig gevulde drager is dankzij de greep aan de bovenkant eenvoudig te verplaatsen
- **Levering zonder werkbakken**

 200 x 630 x 240 mm

Voor 10 werkbakken Nr. 1456 ..

1479 00  2,2 kg

Voor 8 extra hoge werkbakken Nr. 1447 27

1479 01  1,8 kg



Werkbak – kleine uitvoering

- Afm. binnenkant (B x H x D): 138 x 36 x 216 mm

 142 x 39 x 240 mm  10 stuks met etiketten

1455 27 Transparant



Etiketten nabestellen

- Eenzijdige folie (herschrijfbaar)

 10 stuks

0078 00 Voor Nr. 1455 27

0079 00 Voor Nr. 1447 27 en 1456 ..

Assortimentbox

- Met 15 vakken voor verschillende onderdelen
- Gedeeltelijk uitneembare scheidingswanden
- Materiaal: PP

 105 x 23,5 x 178 mm

1435 00



Assortiment box met 5 vakken

- Met 5 vakken voor verschillende onderdelen
- Materiaal: PP

 130 x 35 x 90 mm

1438 00



Vakkendoos, klein

- Materiaal: slagvaste ABS kunststof
- Veilige sluiting
- Stapelbaar
- Inleg met vakverdeling apart verkrijgbaar (Nr. 1446 10 en 1451 10)

 190 x 18 x 126 mm

1445 10



Vakkendoos, middelgroot

- Materiaal: slagvaste ABS kunststof
- Veilige sluiting
- Stapelbaar
- Inleg met vakverdeling apart verkrijgbaar (Nr. 1446 00 en 1451 00)

 190 x 37 x 126 mm

1445 20



Inleg

Voor vakkendoos **Nr. 1445 20**, onderverdeeld in 9 grote vakken.

1451 00



Inleg

Voor vakkendoos **Nr. 1445 10**, onderverdeeld in 9 grote vakken.

1451 10

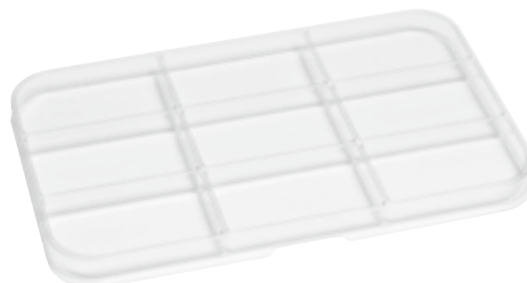

Inleg

Voor vakkendoos **Nr. 1445 20**, onderverdeeld in 25 kleine vakken.

1446 00



Inleg

Voor vakkendoos **Nr. 1445 10**, onderverdeeld in 24 kleine vakken.

1446 10

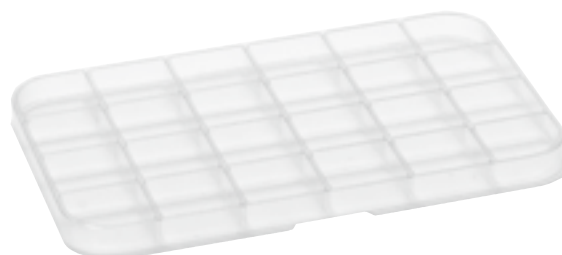

Onderdelendoos

Met 7 afzonderlijk te openen vakken voor onderdelen.
Kleur: Transparant

∅ 8,7 cm

 3 stuks

1437 00



Klein formaat – Groot voordeel!

Plaatsbesparend, overzichtelijk en altijd bij de hand.

Klapboxen

- Zelfsluitend transparant deksel
- Veelzijdig aan elkaar te zetten
- Verschillende maten kunnen onderling worden gecombineerd



Klapboxen, schuine bodem

- Voor neuspads, schroeven enz.
- De schuine bodem en afgeronde hoeken maken het uitnemen van onderdelen makkelijker
- Afm. binnenkant (B x H x D): 37 x 10/15 x 40 mm

 42 x 18 x 57 mm

 4 stuks

1457 11 Wit

1458 21 Blauw



Klapboxen

- Voor neuspads, schroeven enz.
- Afm. binnenkant (B x H x D): 37 x 15 x 40 mm

 42 x 18 x 57 mm

 4 stuks

1457 10 Wit

1458 20 Blauw



Klapbox Grijs

- Voor oortips
- Afm. binnenkant (B x H x D): 57 x 15 x 68 mm

 63 x 18 x 85 mm

 4 stuks

1459 30



Klapbox Wit

- Voor schroeven, ringen en moeren
- Afm. binnenkant (B x H x D): 37 x 15 x 12 mm

 43 x 18 x 29 mm

 4 stuks

1457 20



Onderdelenkast, met drie laden, incl. klapboxen

- **Compleet gevuld met:**
36 stuks klapboxen, Nr. 1457 10, wit, **leeg**
36 stuks klapboxen, Nr. 1458 20, blauw, **leeg**
16 stuks klapboxen, Nr. 1459 30 grijs, **leeg**
- Kastkleur: Lichtgrijs

 265 x 108 x 364 mm

1459 50



Onderdelenkast, met drie laden, zonder klapboxen

- In wit, blauw en grijs voor het overzichtelijker sorteren van onderdelen
- Voor de klapboxen Nr. 1457 10, 1457 20, 1458 20 en 1459 30
- Max. vulling per lade, zie Nr. 1459 50
- Kastkleur: Lichtgrijs

 265 x 108 x 364 mm

1458 50



Gratis!

Wie minstens 20 verschillende brilonderdelen bestelt, ontvangt de bijpassende boxen gratis!



Inhoud voorbeeld



Cosmetica spiegel staand

- Diameter: 17 cm
- Hoogte: 23 cm
- 1 x en 2 x vergroting

7290 02



Cosmetica spiegel met zuignap

- Diameter: 20 cm
- Met 3 x vergroting

7290 01



Cosmetica handspiegel

- Diameter: 17 cm
- Totale lengte: 30 cm
- 1 x en 2 x vergroting

7290 03





Trefwoorden

0–9

4-in-1 schroeven

F 33–F 35

A

Aambeeld
Aambeeldtoren
Acetaat oortips
Acetaatplaten
Aceton
Additief UV-filter
Afnameblokken
Air Active Pads
Anti-slip oortips
Anti-torsie folie
AQUARIUS soldeer- en lasapparaat
Assortimentboxen

C 15
C 15
F 60–F 62, F 64, F 76
F 86
E 17
E 21
E 2–E 3
F 6
F 70–F 71
E 8
A 31
G 10–G 13

B

Balansliniaal
Bankschroeven
Beschermdoppen
Beschermfolie
Beugel- en figuurzaag
Binoculaire voorhanger
Biofeel-pads
Bionic Thumb
Boorfrezen
Boorgatfrezen
Boorgatontbramer
Boormachines en toebehoren
Boorstanders
Boren
Borgmiddel voor schroeven
Boringmeter
Brilkoordjes en brilkettingen
Brilveer buigtangen
Brokkeltang
Buigtangen

D 8
C 42
F 51
E 8
C 43
D 9
F 6
B 30–B 31
C 33, C 35
C 29
C 29
A 26–A 30
A 29
C 32, C 34
E 15
C 23
zie www.optiplus.nl
B 32
B 35
B 12–B 14

C

Canule kunststof
Centertangen
CLAVULUS met toebehoren
Clip on
Comfortpads
Consumenten ultrasone baden
Contactlenshouder met toebehoren
Cosmetica handspiegel
Cosmeticaspiegel
Cosmeticaspiegel staand
CR 39 glazen
Curvetangen

E 16
B 33
A 40–A 43
zie www.optiplus.nl
F 6
zie www.optiplus.nl
D 18–D 19
G 14
G 14
G 14
zie www.optiplus.nl
B 10–B 11, B 32

D

Deblockertang
Derde hand
Derde hand met moerengrijper
Desinfectiedoeken
Diamantbezet gereedschap
Diamantschijven
Diktemeter
Dopmoeren
Doseerpunten
Driepuntstang
Druppelpen

B 36–B 37
C 14
C 14
E 21
C 35
A 21
D 23
F 49
E 16
B 14
E 17

E

Elektrolyt
Elmasonic P30H

E 35
A 10

F

Figuurzaag en toebehoren
Fine Line Ruler
Fixatiekubus LANG
Flexscharnier tangenset
Flexscharnieren + binnenwerk
Flexscharnierschroeven
Föhns
Foliestift
Frezen

C 43
D 28
D 10
B 43–B 44
F 55
F 39–F 42
A 14–A 17
E 10
C 30, C 33–C 36

G

Gereedschaphouders
Gereedschapreiniger diamant
Gereedschaps- en onderdelenetui
Gereedschapset voor glasbrillen
Gereedschaptas voor broekriem
Glanswas
Glas decostiften
Glasbescherming Henry
Glasboormachine + toebehoren
Glasbrillen richttang
Glasbrilringen
Glasbrilschroeven
Glascement
Glaskleurmachine
Glaslijmen
Glasliniaal
Glasmarkeerstift
Glaspads
Glasnijder
Glasversteltangen
Goudsoldeerdraad
Gradenboog
Grafiet drukstift
Grafietstift reservepunten
Gravure herkenner
Groefmachine en toebehoren
Groevenfrees

C 37
E 33
B 47
C 29
B 47
E 30–E 31
E 26
C 24–C 25
A 26
B 27
F 50–F 51
F 36
E 13
A 39, E 20
E 13
D 28
E 10
F 12
C 19
B 34
E 37
D 29
E 10
E 10
A 37
A 18–A 21
C 33

H

Hamers
Hand CLAVULUS
Handslijpsteen
Handslijpsteen V- facet
Henry glasbescherming
Hilco Logic® pads
Hilco Logic® schroeven
Hitte olie
Hitte stop
Houder voor UV-gel
HSS boren
Hulsmoeren
Hulzen voor glasbrillen
Hydrotac leesdelen

C 18
C 13
A 22–A 23
A 22
C 24–C 25
F 11
F 42
E 21
E 35
E 11
C 32
F 51
F 52–F 53
D 13

I

ic! berlin pads
ic! berlin veren en kousensets
Inbus schroevendraaiers
Inclineertangen
Inkt remover stift
Inlegrand
Inlegranden en draad
Insmeltscharnieren
Intrekband
Ishihara kleurkaart

F 11
F 65
C 8
B 3, B 6–B 7
E 10
F 84
F 84
F 57
F 85
D 10

K

KAANS Patch®
Klapboxen
Kleingereedschap assortiment

D 16
G 12–G 13
C 31

Kleurkaarten
 Kleurpasta
 Kleurpoeder
 Klinkscharnieren
 Klinkstiften
 Kopkniptang
 Krasbeschermfolie
 Kraspen
 Krimpkouss
 Krimpkouss voor tangen
 Kruiscylinder
 Kunststof materiaal
 Kunststof pads

D 10
 E 25
 E 20
 F 56
 F 57
 B 39–B 40
 E 8, E 22–E 23
 E 33
 F 74–F 75
 B 46
 D 8
 F 86
 F 10

Oogkappen
 Ooglidsteun
 Oortips
 Opdrachtmappen en -hoezen
 Oplosmiddel voor lijmen
 OptiCar moersleutels
 OptiCar schroevendraaiers
 Opticiensaambeeld
 OPTIFORMA Föhns
 OPTIMONSON Föhns
 OPTISCAN transmissie apparaat
 OPTOCLEAN
 OPTOSONIC Ultrasoos

D16
 F 87
 F 58–F 71, F 76
 G 3–G4
 E 14
 C 5
 C 3
 C 15
 A 12–A 13
 A 14–A 15
 A 37
 E 19
 A 8–A 9

L

LANG fixatiekubus
 Leesbril adapter
 Leesbrillen
 Leesdeelhoogtemeter
 Leesdelen
 Lens Grip
 Lensfolien
 Lijmen
 Loctite
 Logic® pads
 Logic® schroeven
 Luchtdrukspray

D 10
 A 21
 zie www.optiplus.nl
 D 24
 D 13
 E 8
 D 12
 E 12–E 14
 E 12–E 15
 F 11
 F 42
 E 18

P

Paddruktang
 Padplaatjes en -kussen
 Padrichttangen
 Pads
 Pads voor ic! Berlin
 Padsteunen
 Paralelltangen
 Pasbrillen
 Pasdozen
 Pasglazen
 PD maten en linealen
 PD meters
 Pincetten
 Plakpads
 Plasti Dip
 Plat draad
 Polarisatiefilter
 Polarisatiefilter test
 Polariserende glazen
 Polijstmateriaal
 Polijstmotoren en toebehoren
 Polijstschijven en borstels
 Polijstwas
 Polycarbonaatglazen
 Precisie vijlen
 Presentatiebox
 Presenteerblad
 Prijsetiketten
 Prismafolie
 Prismafoliën
 Proformic UV lijm
 PVC pads

B 18
 F 13–F 15
 B 20–B 21
 F 2–F 12
 F 11
 F 16–F 19
 B 2–B 3, B 8–B 9
 D 2–D 4
 D 5–D 7
 D 5–D 7
 D 29
 A 2–A 3
 C 16–C 17
 E 4–E 7, F 16–F 19
 E 22–E 23
 F 87
 D 2–D 3
 D 28
 zie www.optiplus.nl
 A 28–A 29
 A 24–A 25
 E 27–E 29
 E 30–E 31
 zie www.optiplus.nl
 C 38–C 39
 G 2
 G 2
 G 5
 D 13
 D 11–D 12
 E 11
 F 8–F 9

M

Magneetstrip
 Malplaatje
 Markeerfolie
 Markeerhulp „APP“
 Markeerhulp B & S
 Markeerhulp The Cube
 Markeerstiften
 Matsubara kleurkaart
 Matteerborstel
 Mengstander + mengnap
 Messing reinigingsborstel
 Microvezeldoeken
 Mini schroevendraaier
 Moeren
 Moerengrijper
 Moersleutels

B 47
 D 28
 D 24
 F 17
 D 24
 D 26–D 27
 E 10
 D 10
 E 33
 E 16
 E 33
 zie www.optiplus.nl
 C 11
 F 48
 C 16
 C 4–C 5, C 7,
 C 28–C 29
 C 12
 F 82
 C 25, C 27
 F 17
 D 25
 D 10

Moersleutelset
 Monoblock veer voor glasbrillen
 Montagehulp voor glasbrillen
 Montageset padsteunen
 Mütz werkblad
 Multiple Pinhole Occluder

N

Naaldvijlen
 Navulpatroon gas
 Neusbescherming
 Neusbruggen
 Neusbruggen voor Ryban monturen
 Neuspadkussen
 Niethamer
 Nylordraad
 Nylordraadhaak
 Nylorinlegdraad
 Nylorinlegdraad instrument

C 40–C 42
 E 34
 zie www.optiplus.nl
 F 11–F 12
 F 12
 F 13–F 15
 C 18
 F 85
 C 27
 F 85
 C 25–C 26

Q

Q-Check testtoestel

A 36

R

Randdraad
 Reinigingsborstel
 Reinigingsstenen
 Reinigingsvloeistof concentraat
 Reparatiestiften
 Reparatieverven
 Reservepunt grafietstift
 Richttang voor glasbrillen
 Ronddraad
 Ronde spitstang
 Ruimerhouder
 Ruimers
 Ruwe malplaatjes

F 87
 E 33
 E 9
 E 19
 E 24
 E 25
 E 10
 B 27
 F 87
 B 15
 C 37
 C 21
 D 28

O

Occluder
 Occlusiefolie
 Oliën
 Omkeerhouder voor UV-Gel
 Onderdelenset voor glasbril
 Ontkleurder
 Oogdoppen

D 10
 D 15
 E 17
 E 11
 F 81–F 83
 E 21
 D 14

S

Scalpel
 Scharen
 Schanier richttang
 Scharnieren
 Scharnieroog richttang
 Schavers

C 20
 C 20
 B 29
 F 54–F 57
 B 28
 C 18

Trefwoorden

Schroefhouder
Schroeven
Schroeven assortimenten
Schroeven met borg
Schroeven voor Rayban monturen
Schroeven-grip
Schroevendraaier met 5 functies
Schroevendraaier met magazijn
Schroevendraaier Profi set
Schroevendraaierspincet
Schroevendraaiers
Schroevengrijper
Schroevenkniptang
Schroevenkorter
Schroevenverwijderaer
Schuifmaten
Schuimrubber padkussen
Schuimrubberinleg voor laden
Schuimrubberinleg voor werkbakken
Schuurblok rubber
Schuurpapier
Schuurstok
Secondenlijm
Sferometer
Siliconen inleg voor werkbakken
Siliconen oortips
Siliconen pads
Siliconeninleg
Siliconenspray
Slijpmiddeltoevoeging
Slijpschijf steen bros
Slijpselverwijderaer
Sluitblokken
Sluitbloktangen
Snellijmen
Snelspan vijlheft
Soldeer
Soldeer montageset
Soldeer- en lasapparaat AQUARIUS
Soldeer- en lasapparaten en toebehoren
Soldeerdraad
Soldeerdraadhouder
Soldeerscharnieren
Sorteerhulpen voor kleine
en montuuronderdelen
Spangereedschap
Spanningsmeter
Speciaalreiniger voor glazen
Speciale pads
Speciale ringen voor titanium veren
Speciale schroeven
Speciale tang voor schroefloze glasbrillen
Speciale zijknijptangen
Spiraalboren
Spitstang vlak, half rond
Spitstangen vlak
Sportbrilbanden
Sportbrillen
Sportbrilveren
Spuitfles
Stempeltang
Stiften
Strassstenen
Studiemateriaal

T

Taboschema
Tafelboormachine
TAKUBOMATIC groefmachine
TAKUBOMATIC handslijpsteen
Tang speciaal voor schroefloze glasbrillen
Tangen eLite

C 17
F 20–F 46
F 45–F 46
F 41–F 44
F 37
E 13
C 11
C 10
C 2
B 44, C 15
C 2–C 11
C 16
B 27
C 28–C 29
C 13
D 24
F 13–F 15
G 4
G 8
E 32
E 32
E 32
E 12, E 14
D 22
G 7
F 63–F 64
F 4–F 8
C 30
E 18
E 9
E 33
C 18
F 57
B 19
E 12–E 14
C 37
E 36–E 37
F 87
A 31
A 31–A 33
E 34
E 34
F 54

G 10–G 13
C 30–C 41
A 34–A 35
E 17
F 11–F 12
F 50
F 33–F 44
B 26
B 26
C 32
B 17
B 16
zie www.optiplus.nl
zie www.optiplus.nl
F 66–F 70
E 16
B 38
E 10
F 47
F 86–F 87

Tangen Standaard
Tangengreep krimpous
Tangenstanders
Tappen
TENAX strips
The Cube markeerhulp
THERA°PEARL® Eye-ssential™ Oogmasker
Titanium pads
Titaniumdraad
Topsterktemeters en toebehoren
Torx schroeven
Torx schroevendraaier
TPE pads
Transmissie meetapparaat

U

UB4 + UB6
Uitdruktang
Ultrasoonbad
Ultrasoons en toebehoren
Universele stift, fijn
UV lampen en toebehoren
UV lijmen
UV testlamp

D 2–D 3
B 22–B 23
zie www.optiplus.nl
A 10–A 11
E 10
A 38
E 11
A 36

V

Vario blok
Veer mit RAL bak
Veerschroeven
Veiligheidsbrillen
Veiligheidsbrillen assortiment voor kinderen
Veiligheidsmes
Ventilette
Veren
Vijlborstels
Vijlen
Vijlheften
Vlaktangen
Vloeibare inleg
Vloeimiddelen
Vloeistofdispenser
Voorhangers
Voorsteekdoorn

E 2–E 3
F 77
F 43
zie www.optiplus.nl
D 17
C 19
A 17
F 77–F 83
E 33
C 38–C 41
C 39
B 17–B 18
E 13
E 35
E 16
zie www.optiplus.nl
C 23

W

Werkbakken
Werkblad Mütz
Werkplaatsvijlen
Windsorringen
Windsorringtang

G 6–G 9
D 25
C 38–C 41
F 73
B 29

Z

Zaagbladen
Zadelpads
Zagen
Zak schuifmaat
Zelfklevende etiketten
Zelfklevende padkussen
Zelfklappende schroeven
Zijkap – knipbaar
Zijknijptang
Zilver palladiumdraad
Zilversoldeer
Zilveroldeer pasta
Zuurstoffes
Zwembrillen

C 43
F 7
C 43
D 24
G 5
F 14–F 15
F 43
D 14
B 39–B 42
E 34
E 36
E 35
E 34
zie www.optiplus.nl



TIPS & TRICKS

B 12	Curve tangen
B 22	Glasbril tangen
B 30	Bionic Thumb
B 43	Flexscharniertang
C 24	Glasbeschermer Henry
C 26	Nylorinlegdraad instrument
C 28	Schroevenkorter
D 11	Prismafoliën
D 26	The Cube
E 22	Plasti Dip
E 27	Polijsten
F 14	Zelfklevende neuspadkussen
F 16	Padsteunen
F 33	4-in-1-schroeven
F 66	Kruloortips
F 74	Krimpkouss

Symbolverklaring



Opmerking



Diameter



Dikte
randdraad



Langte of breedte



Dikte



Gewicht



Hoogte



Dikte
inlegrand



Verpakking:
stuks/paar



Afmetingen
(breedte x diepte of
breedte x hoogte x diepte)

Ruimte voor uw notities:

A series of horizontal dotted lines for writing notes, arranged in a regular pattern across the page.

Ruimte voor uw notities:

A series of horizontal dotted lines for writing notes, spanning the width of the page.

Ruimte voor uw notities:

A series of horizontal dotted lines for writing notes, arranged in a regular pattern across the page.

Ruimte voor uw notities:

A series of horizontal dotted lines for writing notes, arranged in a regular grid pattern across the page.

Ruimte voor uw notities:

A series of horizontal dotted lines for writing notes, arranged in a regular grid pattern across the page.



Ook deze catalogus is weer op gecertificeerd papier gedrukt – geproduceerd uit duurzaam bosbeheer.

Meer over de milieu-initiatieven op onze homepage:
www.b-s.de



ONZE BIJDRAGE AAN HET MILIEU PAPIER UIT DUURZAME BOSBOUW.



Onze nieuwe catalogus telt 320 bladzijden. In 10 verschillende talen en met een totaaloplage van 25.680 catalogi, zijn dit ca. 8,22 miljoen bladzijden. Omgerekend naar papieroppervlakte is dat een trotse som van ca. 512.532 m². Dat is een krappe 47,5 ton papier.

Dit papier ontvangt de drukkerij van een papierproducent, die zijn bronnen direct uit de natuur haalt. En zo zijn we hier in de gelegenheid niet alleen over milieubewustzijn te praten, maar ook daar naar te handelen.

Daarom hebben we, gezamenlijk met de drukkerij, bij de productie van de B&S catalogus voor papier gekozen dat uit een volledige bewerkingsketen komt: **Inapa Bavaria. Dit houthoudende fotopapier is, net zoals de drukkerij zelf, PEFC gecertificeerd.**

Doel van PEFC is de documentatie en verbetering van de duurzame bosbouw met het oog op economische, ecologische en sociale standaarden. Ondernemingen die PEFC gecertificeerd zijn, tonen betrokkenheid bij het milieu en investeren in duurzame omgang met de grondstof hout.

Wij bij B&S zien de noodzaak om op verantwoorde wijze om te gaan met de begrensde natuurlijke bronnen van onze aarde. En dat bewijzen wij hier „zwart op wit“.

© Breitfeld & Schliekert 2020 | 21_all rights reserved

Initiative	Frank Thiel
Project Management	Katrin Gaarz, Anne Hentrich, Bastian Trumpfheller
Creation / Artwork	ORT Medienverbund GmbH, Tina Hofmann, Toni Menges, Stephanie Scherff, Margret Spitz, Britta Wendland
Photo	ORT Medienverbund GmbH, Behrendt & Rausch, Martin Joppen Photographie
Production	Bonifatius GmbH, Druck Buch Verlag



B & S is wereldwijd vertegenwoordigd



Optiplus B.V.

Molenwiek 3-A
9351 ND LEEK
Tel.: +31-(0)50-5515200
Fax: +31-(0)50-5515252
E-mail: info@optiplus.nl
www.optiplus.nl

Optiplus Belgium

Schaliënhoevedreef 20T
B-2800 Mechelen
België/Belgique
Tel +32 (0)15 79 50 30
E-mail info@optiplusbelgium.be
www.optiplusbelgium.be

Hier kunt u uw klantnummer noteren